

Schaltertype /Switch type:  
RLT25/6PM-D2/Z33/HV11

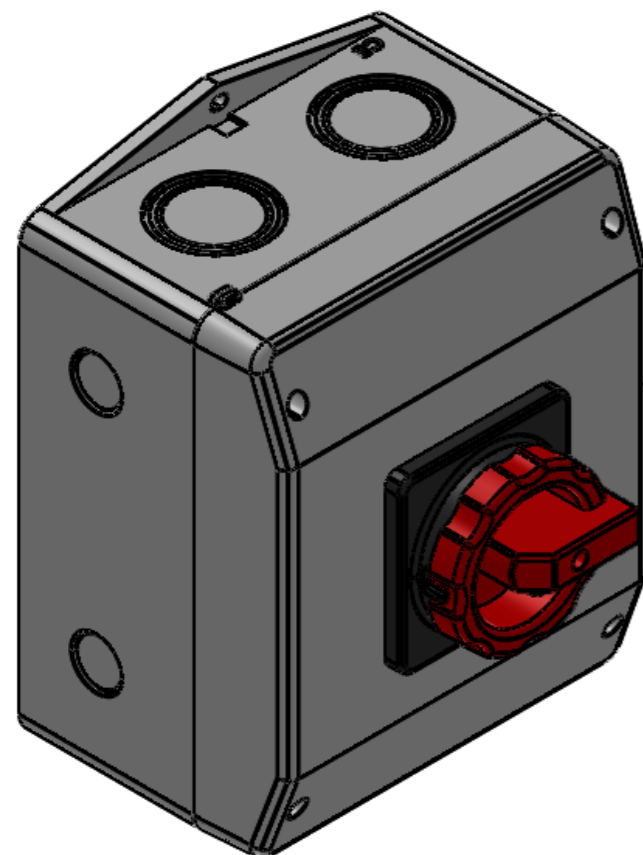

Ue  
Ith  
AC23 (400V)  
AC3 (400V)  
Anschlussquerschnitt max / Connection cross  
Drehmoment Klemmen / Torque clamps  
Verlustleistung je Kontakt bei Nennstrom / Power loss 1 contact:  
Umgebungstemperatur / Ambient temp:  
Schutzart / Protection

690VAC  
25A  
9,5kW  
7,5kW  
16mm<sup>2</sup>  
2Nm  
1,1W  
-30°C - +70°C  
IP65

Hilfsschalter für LT/LO-Reihe / Auxilliary switch for LT/LO-series		IEC 60947-5-1	
Bemessungsisolationsspannung	/ Rated insulation voltage	Ui	V
therm. Dauerstrom	/ Thermal Uninterrupted current	Ith	A
AC-15	120 V	A	6
	220...240 V	A	3
	380...415 V	A	1,8
	500 V	A	1,4
DC13	125 V	A	1,1
	250 V	A	0,3
Anschlussquerschn. starr	/ solid wire	mm <sup>2</sup>	2x 0,75...4
Anschlussquerschn. flexibel m. Aderendh.	/ flexible with wire end ferrules	mm <sup>2</sup>	2x 0,75...4
Anzugsmoment Klemmen	/ Tightening torque clamps	Nm	0,8...1,1