



# ENAPART



93 S Railroad Avenue Unit C  
Bergenfield NJ 07621 USA  
[www.enapart.com](http://www.enapart.com)  
[sales@enapart.com](mailto:sales@enapart.com)



Via del Canneto 35,  
Borgosatollo, Brescia - Italia  
[www.enapart.it](http://www.enapart.it)  
[vendite@enapart.it](mailto:vendite@enapart.it)



Barbaros Mah. Ihlamur Bul. Aĝaoĝlu  
My Newwork No:3/15 Ataşehir / İstanbul  
[www.enapart.net](http://www.enapart.net)  
[satis@enapart.net](mailto:satis@enapart.net)



PRIVADA 10 B SUR #3908 COL.  
ANZUREZ, C.P. 72530, PUEBLA, PUE  
[www.enapart.com.mx](http://www.enapart.com.mx)  
[sales@enapart.com.mx](mailto:sales@enapart.com.mx)



Friedrich-Ebert-Anlage 36, 60325  
Frankfurt am Main, Germany  
[www.enapart.de](http://www.enapart.de)  
[anfrage@enapart.de](mailto:anfrage@enapart.de)



4 boulevard Carnot, 95400  
villiers-le-bel, Paris, France  
[www.enapart.fr](http://www.enapart.fr)  
[sales@enapart.fr](mailto:sales@enapart.fr)



65049, ОДЕСА, ВУЛИЦЯ ІВАНА  
ФРАНКА, БУДИНОК 55, ПОВЕРХ 3  
[www.enapart.com.ua](http://www.enapart.com.ua)  
[sales@enapart.com.ua](mailto:sales@enapart.com.ua)



MUNICIPIUL BUCUREȘTI, SECTOR 3,  
B-DUL BASARABIA, NR.250, CORP P+5  
[www.enapart.ro](http://www.enapart.ro)  
[sales@enapart.ro](mailto:sales@enapart.ro)



〒584-0023 大阪府富田林市若松町  
東2丁目2番16号  
[www.enapart.co.jp](http://www.enapart.co.jp)  
[sales@enapart.co.jp](mailto:sales@enapart.co.jp)



PLAZA NUESTRA SEÑORA DE LAS  
NIEVES 12 ,LOCAL ,50012,ZARAGOZA  
[www.enapart.es](http://www.enapart.es)  
[ventas@enapart.es](mailto:ventas@enapart.es)



Складова база „Онгъл“, Склад А2, п.к.  
4006, гр. Пловдив, България  
[www.enapart.bg](http://www.enapart.bg)  
[sales@enapart.bg](mailto:sales@enapart.bg)



3 Austin Mews, High Street, Hemel  
Hempstead, HP1 3AF , United Kingdom  
[www.enapart.co.uk](http://www.enapart.co.uk)  
[sales@enapart.co.uk](mailto:sales@enapart.co.uk)

**saia**

**Motors**



**SAIA Motor Catalog**

**Johnson Electric**

**JOHNSON  
ELECTRIC**  
innovating motion

The data used in this Product Overview may be used as a guideline only. Specific operational characteristics of our products may vary according to individual applications. It is strongly recommended that specific operating conditions are clarified with Johnson Electric before application.

Johnson Electric Terms and Conditions of Sale apply.

All data may be subject to change without notice.

# Table of Contents

<b>Content</b>		<b>Gearboxes for Motors</b>	<b>84</b>
Overview	2	UGY	85
How we are organized	3	UGD	87
Looking for a specialized motor solution?	4	UGM	90
Saia – a leading global motor brand	5	UGB	93
Motors for Pharmaceutical and Medical Equipment	6	UGF	96
Motors as Locking Mechanism	7	UGV	99
Motors in the Appliance Industry	8	UGO/UGP	101
Table of typical applications & Saia Motor Series	9	AP 60	105
Saia Motors Important notes	10	UGJ	106
Synchronous Motors	15	UGR	109
Stepper Motors	16	UGW	112
Gearboxes	17	<b>Gearboxes with DC &amp; BLDC Motors</b>	<b>114</b>
Gearboxes with DC and BLDC Motors	18	UGM-DC	115
Synchronous Motors	19	UGB-DC	117
Electronics for Stepper Motors	20	UGF-DC	119
<b>Synchronous Motors Rotational</b>	<b>21</b>	UGO-DC	121
UAT3	22	UGP-DC	123
UCM	25	<b>Synchronous Motors Linear</b>	<b>125</b>
UCR	28	UCC	126
UBR1	31	UCK	130
UBR2	33	<b>Stepper Motors Linear</b>	<b>134</b>
UDR	35	UAL	135
UDS	37	UCE	139
UFM	39	UCL	144
UFU	41	Connection Types UC motors	149
UFR	43	<b>Electronics for Stepper Motors</b>	<b>150</b>
UPU	47	Samotronic101	151
<b>Stepper Motors Rotational</b>	<b>51</b>	Samotronic102	152
UAG3/4	52	Evaluation-Kit 2	153
UCD	56		
UCB	60		
UBD	64		
UBB	67		
UDB	70		
UFD	73		
UFB	76		
UPJ	81		

# Overview

---

**The Johnson Electric Group is one of the world's largest providers of motion subsystems and motion components for automotive, medical and industrial applications.**

---

Over the years, we have shipped billions of motors to more than thirty countries in over one hundred different applications. Johnson Electric has an annual production capacity of one billion motors and motion subsystems.

---

At the heart of Johnson Electric's success is our commitment to make our customers successful. Our customers include many of the world's leading industrial, consumer and automotive companies. We begin by understanding our customers' business needs, and the product application requirements of the end user of our customers' products. Then we design and deliver innovative motion solutions that help our customers to differentiate their products in the marketplace. Our goal is to be instrumental in the successful launch of our customers' products in their respective marketplaces.

## **Our Brand Promise** **Johnson Electric delivers competitive advantage**

Johnson Electric delivers differentiation and innovation through its motion products – subsystems comprising of Stepper Motors, DC Motors, AC Motors, Piezo-electric Motors, Switches, Solenoids, Flexi Circuits, Motion Control, Precision Plastics and Precision Gears.

## **Johnson Electric is the most reliable partner**

Johnson Electric is responsive and flexible; and has the financial stability and organizational integrity to meet all of our commitments and to support our customers' success. Product reliability and assurance of supply are our commitment.

## **Johnson Electric is "The Safe Choice"**

- Financial strength and long standing supplier relationships.
- Unmatched assurance of supply.
- Rigorous supply chain management and complete integrity in compliance with standards.
- Unsurpassed on-time delivery.
- Global logistics support 24/7.
- Collaborative design and project management process.
- Product life cycle support from creation to end-of-life.

Our business growth hinges with leading «branded» goods producers to deliver differentiation and innovation through our motion products. The core platform for delivering these solutions is a highly developed production base and focused customer support teams throughout the world. This combines scale advantages in production and procurement with skilled and dedicated motion application experts.



# How we are organized

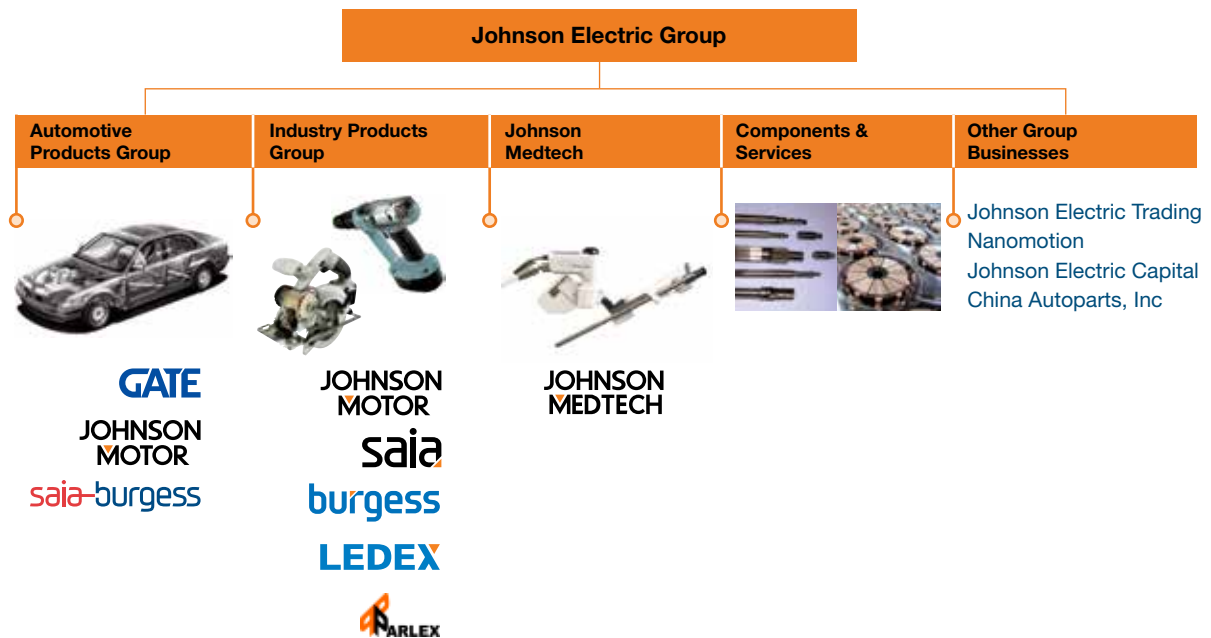

## The Group's motion systems, motors and switches businesses are managed through three operating divisions: Automotive Products Group, Industry Products Group and Johnson Medtech.

The Automotive Products Group (APG) is focused on providing customized motion solutions for all major automotive applications. APG goes to market under three product brands: Saia-Burgess for custom actuators; GATE for engine cooling fan modules; and Johnson Motor for DC motors and brushless DC motors.

The Industry Products Group (IPG) provides motion products and solutions for various commercial and industrial application sectors, including home appliances, power tools, business equipment, personal care products, medical equipment, building automation, security, audio-visual and other industrial products. IPG goes to market under several product brands: Johnson Motor for DC motors, AC motors and BLDC motors; Saia Motor for stepper motors and synchronous motors; Ledex for solenoids; and Saia, Burgess, brands for switches.

Johnson Medtech is an ISO13485 certified designer and manufacturer of motion related products for the medical device industry. The focus of Johnson Medtech is

primarily in subsystem for medication delivery systems, surgical robotics and image guided surgery.

Supporting these three business units is the Components & Services division which produces metal and plastic parts, tooling and production equipment for the Group. Johnson Electric is a highly vertically integrated business that manufactures an exceptionally wide range of components that form the basis for its final products. We make magnets, bearings, shafts, housings, laminations, commutators and die cast parts. We also build tools, assembly fixtures, plastic molds as well as armature winding and other production machines.

Supporting our customers worldwide are sixteen R&D centres located in Hong Kong (China), Shenzhen (China), Shanghai (China), Nagano (Japan), Yokneam (Israel), Asti (Italy), Murten (Switzerland), Halver (Germany), Dresden (Germany), Isle of Wright (Parlex), San Jose (USA), Methuen (USA), Vandalia (USA), Springfield (USA) and Plymouth (USA).

The Group also includes a number of complementary subsidiary companies. These include an innovative provider of flexible printed circuits and interconnect solutions; a successful niche player in the programmable controls industry; and a rapidly growing China auto parts business.

# Looking for a specialized motor solution?

---

## Look no further.

We offer the industry's most comprehensive combination of technology, engineering and manufacturing to satisfy all your actuation design needs. From stand-alone motor products to complete value-added solutions; we can do it all for you. The images shown are just a few samples that demonstrate our design and value-added assembly capabilities.

If your application requires more than a standard product solution, please consider us early in your design process. Our application engineering staff will be happy to discuss your requirements.



# Saia – a leading global motor brand

We offer the best design resources for actuating solutions – whether it's one motor delivered tomorrow morning or a half million delivered just-in-time over the next year.

Machine and process automation can range from the most basic on-off function to extremely complex sequencing. When the process involves linear or rotary motion, motors are among the best actuation devices in terms of size, cost, simplified installation, and ease of use. On this page are some of the primary functions which are ideally suited for Saia motors, followed by several pages of current application examples of our products applied in a wide variety of industries. If your design includes linear or rotary operations, we can help you determine the best product to meet your application design requirements.

## Variable Positioning

Stepper motor for linear applications and rotary applications provide variable positioning capabilities.

## Uncompromising Reliability

Saia motors provide repeatable, predictable performance.

## Common Rotary Motor Applications

- Counters
- Circuit breakers
- Rotary valves
- Rotating lamps
- Textile machinery
- Flaps
- Level indicators
- Ticket machines
- Copiers

## Common Linear Motor Applications

- Coffee machines
- Textile machinery
- Linear valves
- Vending machines

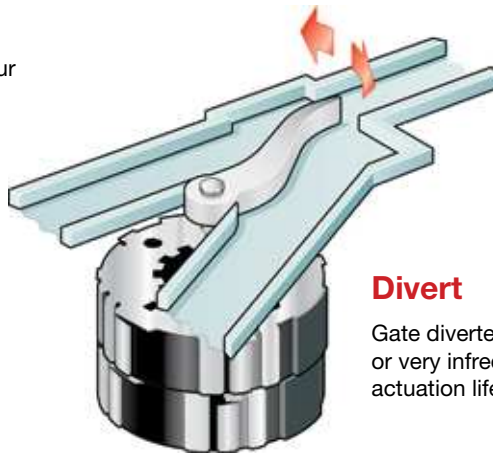

### Divert

Gate diverters, depending on the application, can be used continuously or very infrequently. In this example, a stepper motor unit is chosen for its actuation life rating.

### Pinch

In this example, a linear motor is utilized for its variable positioning capability to smoothly pinch the tube to the operator's precise demand.

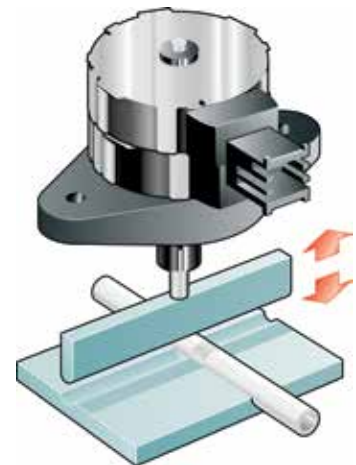

### Position

Positioning applications can range from a simple ratcheting device, such as this, to precise variable positioning using linear or rotary motor.



# Motors for Pharmaceutical and Medical Equipment

---

Saia motors are ideally designed for precise, clean, quiet, reliable automation of a variety of medical equipment functions.

Inherent features which optimize linear and rotary motor use in the medical industry include:

- Easy control with simple electronics
- Instant actuation or smooth variable positioning
- High MTBF, reliable, repeatable operation without degradation due to wear
- Long, predictable life
- Ideal for both open loop or closed loop microprocessor controlled systems

## Pharmaceutical Dispenser

- Locks storage trays closed
- Locks individual medicine compartments
- Counts tablets as dispensed

## IV Fluid Metering

- Acting as pinch valves, motor offer a simple, direct, reliable means to start and stop fluid flow through valves or tubing
- Principle motor design advantages include non-contacting, quiet operation with minimal heat generation
- Also, depending on the design requirements of the application, either immediate on/off or slow, proportional actuation can be achieved

## Intraocular Microsurgery

- Motors are used to control fluid flow through a series of tubes during intra-ocular surgery
- Reliability is a primary motor advantage because a malfunction during surgery could be detrimental

## Surgical Laser

- Motors are commonly used as the shutter mechanism for surgical lasers.

## Portable, Real-Time Blood Analyzer

- A bedside blood analyzer allows blood to be monitored during administration of medicines allowing doctors to prescribe medications in more exacting dosages based on the patient's condition

# Motors as Locking Mechanism

---

Motors are found in numerous applications that require a locking device. Whether it is a medical application, an office automation application or a door lock, motors provide an effective, cost-efficient locking mechanism.

## Security Applications

- Hotel room door lock
- Hotel safe lock
- Prison door lock
- Fire safety door opening lock

## Office Automation

- Disk drive door lock
- Personal computer chassis lock
- Docking station lock
- Locks to hold peripherals in place
- Tape library index lock

## Medical

- Sterilizer lock
- Centrifuge lock
- Blood analysis machine lock

## Consumer

- Oven door lock for self-cleaning function
- Garage door safety lock
- Home safe lock

## Industrial

- Overhead door lock
- Fire safety door lock
- Prison locks
- Commercial laundry locks

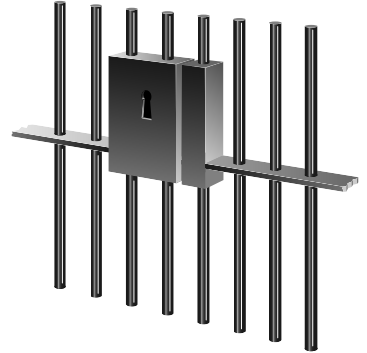

# Motors in the Appliance Industry

---

Motors are found in numerous applications in the appliance industry. AC and DC products are available for on/off operation on many types of consumer and commercial appliances.

## Domestic Appliances

- Through the door refrigerator ice and water dispensers
- Door locks on self-cleaning ovens
- Gas valve control on gas ranges and ovens
- Drain control valves on domestic washing machines
- Brake motors on domestic washing machines



## Commercial Appliances

- Dispensing valves
- Beverage dispensing valves
- Product dispensers on vending machines
- Coin changers on vending machines
- Actuating devices on commercial baking and food processing or packaging equipment
- Wrapping material cutters for food packaging
- Gas valve control on gas fired boilers and furnaces
- Industrial overhead door brake mechanisms

# Table of typical applications & Saia Motor Series

In addition to the products shown in the Product Catalog pages, the Product Mapping table below shows a wide range of motor types for a selection of applications. Also, motors may be customized to fulfill your specific requirements, please feel free to contact us.

Application & Motor types	UAT3	UCM/UCR	UBR1/UBR2	UDR	UDS	UFM/UFU/UFJ	UPU	UAG3/4	UCD/UCB	UBD/UBB	UDB	UFD/UFB	UPJ	UGY	UGD	UGM	UGB/UGF	UGV	UGO/UGP	UGJ	UGR	UGW	UCC/UCK	UAL	UCE/UCL	
HVAC/Diverter valves	•	•	•		•			•	•	•													•		•	
HVAC/Thermostatic valves	•					•																				
Coffee machines	•							•	•					•				•						•	•	•
HVAC / Air Flaps	•	•																•						•	•	•
Vending/Gaming	•	•	•	•	•	•		•		•		•		•										•		•
Industrial Equipment	•	•	•	•	•	•	•	•	•	•	•	•	•		•		•	•	•		•		•	•	•	•
ATM																										
Medical			•	•	•	•	•			•	•	•			•		•	•		•			•	•	•	•
Commercial Equipment	•	•	•	•	•	•	•	•	•	•	•	•	•		•			•							•	
Pellet stoves						•						•														
Level indication					•																					
Textile machines									•									•						•	•	
Credit card readers								•																		
Pan and tilt cameras																										
Chart recorders								•																		
Tachograph								•																		
Conveying						•	•					•														
Mechanical handling																		•							•	
Copier & Printer					•	•				•	•	•		•												
Distribution		•	•		•	•	•		•	•	•	•	•		•	•	•	•	•	•	•			•		•
Home Appliances			•	•	•	•		•	•					•	•		•	•						•	•	•
Industrial automation		•																•						•		
Specialist vehicles					•					•	•	•														
Waterheaters/Showers			•		•						•	•														
Circuit Breaker			•			•				•		•							•			•				
HVAC	•	•	•	•	•	•	•		•	•	•	•	•	•	•	•	•	•	•	•	•		•	•	•	•
Page	22	25/28	31/33	35	37	39/41/43	47	52	56/60	64/67	70	73/76	81	85	87	90	93/96	99	101	106	109	112	124/128	133	137/142	

# Saia Motors Important Notes

## General

All specifications are representative only and maybe subject to variation. For confirmation of values, please contact Johnson Electric.

Saia motors fulfill basis insulation requirements of EN 60335-1: 2012.

### Application advice

The requirements for protection class I, II or III according to EN 60335-1 have to be fulfilled by customer application.

## Stepper motors

Specified data for torque values is valid for

- a duty cycle of 100%, in Performance Charts additionally for 30% (cycle time: 5 min.)
- an ambient temperature of  $23 \pm 5^\circ\text{C}$
- a defined driver circuitry, with constant voltage supply
- at rated voltage

Depending from operational conditions, max. load torque must be lower than specified torque in catalogue. Please send us an enquiry.

If duty cycle or actual maximum ambient temperature is lower, the motor can be designed for higher performance (torque and power) by using a different winding.

Chopper driver circuits can be applied alternatively to a driver with constant voltage supply. They are more expensive, but bring higher performance. Additionally, they reduce the effects of temperature and supply voltage change.

Performance charts available on request.

Step angle tolerance is about  $\pm 5\%$  (not cumulative)

## Synchronous motors

Specified data for torque/power values are valid for

- a duty cycle of 100%
- an ambient temperature of  $23 \pm 5^\circ\text{C}$
- at rated voltage
- synchronous torque (pull-out torque, not starting torque)

Torque is specified with maximum values, overloading is not permissible.

Depending from operational conditions, max. load torque must be lower than specified torque in

catalogue. Please send us an enquiry.

If duty cycle or actual maximum ambient temperature is lower, the motor can be designed with higher performance by using a different winding.

The basic design is the same as for our stepper motors, but the motors are operated by a sinus waveform voltage.

A capacitor, connected to one of the motor coils, is necessary for rotation in the appropriate direction.

Motor type UDS is a special design: It has only one coil, but is fitted with an internal backstop. This backstop forces the motor to rotate only in one direction.

Motor can be designed to rotate in CW or in CCW direction. A capacitor is not necessary.

## Mechanical and electrical connections

On request we can deliver other options, e. g.

- special motor shafts
- pinions on shaft
- special cable lengths
- connectors

## Gearboxes

Saia gearboxes are available in a variety of sizes to meet a wide range of torque requirements. Ratios from 4 1/6 to 6.048.000 are available. The basic design is a spur gearbox with gear wheels in metal, plastics and combinations of the two materials. A particular feature is the availability of freewheels and slipping clutches.

The gearboxes are turned by the motor, energy flow is from input to output shaft. That means, they are not allowed to be driven by the output shaft (for instance turning manually). This can lead to damage of some internal components!

## Direction of rotation

As a function of the number of stages, the direction of rotation can be either clockwise or counter clockwise. The direction of rotation of motor gearbox units is generally specified by the gearbox output shaft (drive-side, see DIN EN60034-7, IEC 60050-411).

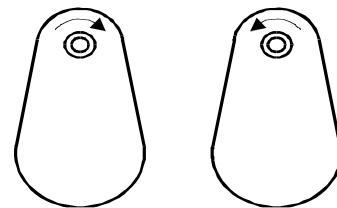

clockwise

counter clockwise

## Ratio

Gear ratio  $i$  is the ratio of input speed  $n_e$  and output speed  $n_a$ .

$$i = \frac{n_e}{n_a}$$

## Permissible force FA and FR at the output shaft

Permissible force loads at the output shaft are:

- Axial load (or thrust)  $F_A$ , pulling or pushing in axial direction of the shaft
- Radial load  $F_R$  acting laterally on the shaft.

The catalogue value is referred to a distance of 1 cm to the bearing

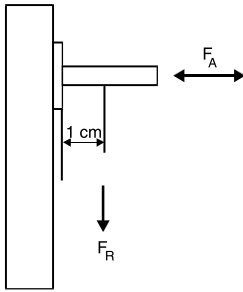

## Permissible Torque

The lifetime of a gearbox is determined by the load on the gear teeth and the number of revolutions of the gear wheels.

The maximum permissible torque  $M_n$  is defined by the load on the final stage of the gearbox and the stability of the housing.

Some gearboxes have lifetime graphs. It shows the relationship between ratio  $i$  and the associated torque for a fixed period of time, e.g. 1000 or 10000 hours. A conditional parameter is the input speed (equivalent to motor speed) corresponding to the total number of revolutions of all gear wheels. In the catalogue we show two curves – for a motor having 250/300 rpm and 500/600 rpm.

For example: Max. output torque  $M_{x1}$  is permissible at a ratio of  $i_{x1}$ . With smaller ratios the max. permissible torque has to be reduced, because otherwise the first stages of the gearbox would be overloaded.

Additionally to the lifetime curve the motor torque  $M_m$ , multiplied by gear ratio and reduced by the gear efficiency, is shown (resulting in output torque  $M_i$ ).

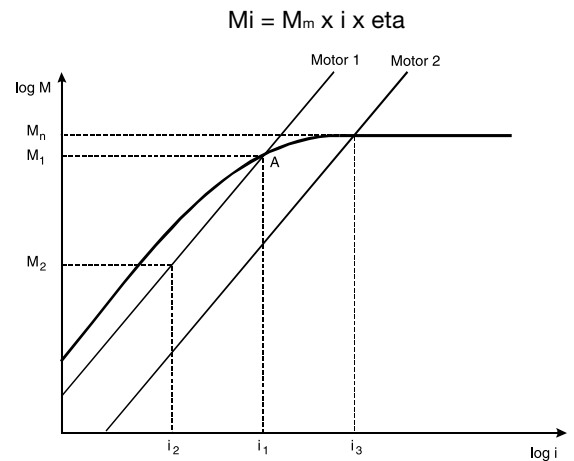

Example 1: The application of Motor 1 combined with a gearbox of ratio  $i_1$  leads to an output torque  $M_1$  at point A. The gearbox can transmit this torque, meeting its lifetime.

If a ratio of  $i > i_1$  is selected, actual torque would be  $M > M_1$ . However lifetime cannot be guaranteed, as the operating point lies above of the lifetime curve now.

Example 2: Motor 1 with a ratio of  $i_2$ . Torque generated is  $M_2$ . This is below of the lifetime curve. Lifetime of gearbox is higher.

Example 3: Motor 2 and a ratio of  $i_3$  generate a torque of  $M_n$ . When using a ratio of  $i > i_{x3}$  - the gearbox cannot be loaded more than  $M_n$ .

## Efficiency

The efficiency is determined by the number of gearbox stages.

Efficiency of UGO/UGP and UGR is specified in catalogue

Efficiency of all other gearboxes on request.

## Clutches

Gearbox types UGB and UGD can be fitted with freewheels or slipping clutches. Freewheels transmit the max. torque M in the locked direction, <1 cNm in the opposite direction. One way slipping clutches behave similarly except that the slip torque has a higher value. Two way slipping clutches can only transmit a limited torque value in either direction lower than the slip torque.

Slipping clutches are used to: Protect the gearbox against torque overloads, or to adjust the load by turning from the load side (remember: turning the output shaft directly can otherwise damage the gearbox).



Slipping clutch	One way	One way	Two way
Freewheel	yes	yes	no
Torque, clockwise	full torque	< slipping torque	< slipping torque
Torque, Anti clockwise	< slipping torque	full torque	< slipping torque
Output shaft turning, clockwise	slipping possible	blocking	slipping possible
Output shaft turning, anti clockwise	blocking	slipping possible	slipping possible

## Explanation of specifications

### Power consumption $P_{in}$

The power consumption (in W) was determined in no-load operation

### Load

The total sum of all static and dynamic torques (e.g. friction torque, mass inertia, acting on the rotor).

### Speed n

rmp revolution per minute

### Torque

The running torque in cNm (also synchronous, braking or dynamic torque) defines the load at which the synchronous motor falls out of synchronism and stops.

## Power output

The power output (in W) is determined according to the following formula

$$P_{out} = \frac{M \times 2 \pi \times n}{60} = [W]$$

M in Nm (1 cNm = 0,01 Nm), n in rpm

## Pole pair number

The number of rotor pole pairs North/South.

## Direction of rotation

This information always refers to the output shaft, either of the motor or of the gearbox.

Right = clockwise rotation (CW),

Left = counterclockwise rotation (CCW)

## Gear torque

The maximum gear torque in cNm defines the maximum load for a required life of at least 1000 operating hours.

---

## General technical terms relating to synchronous and torque limited synchronous motors

### ED or Synchronous

The running of the rotor at the same speed as the stator field which is determined by the frequency of the supply.

### Synchronous speed

Constant speed of rotation at constant frequency based upon the number of pole pairs of the motor

$$n = \frac{f \times 60}{p}$$

f = frequency (Hz), n = speed (rpm)  
p = number of pole pairs

### Synchronous torque

Load torque permissible without motor falling out of synchronism, once the synchronous speed has been reached.

### Starting torque

Load torque the motor is capable to start.

It is influenced by the type and manner of coupling to the load, the load inertia, the gearbox design and the supply voltage. In the case of a very large reduction ratio a small external moment of inertia and nominal gearbox play the starting torque becomes equal to the synchronous torque.

### Detent torque (static)

Defines the maximum torque which can be applied to a deenergised motor without causing the motor to rotate. Catalogue specifications refer to the static detent torque.

### Detent torque (dynamic)

Defines the maximum torque at which the motor comes to an immediate standstill from synchronous running when the power supply is switched off.

### Permissible load inertia

Is the maximum inertia load the motor can start without external help.

## Stall-proof

Synchronous motors with permanent magnet rotors can be stalled without damage to the motor winding.

## Design characteristics

The basic design is the same as for our stepper motors, but the motors are operated by a sinus waveform voltage.

## General technical terms relating to stepper motors

### Duty Cycle (ED)

Duty cycle of operation, based on a cycle time of 5 minutes (1 minute for URG) and a frequency f=0Hz; e.g. ED=30% means that the motor can be continuously powered 1.5 minutes (30% of 5 minutes) without overheating

### Step angle

Rotary angle through which the motor shaft turns per controlled pulse.

### Stepping frequency

Number of steps of the stepping motor in 1 sec.

### Driver

Electronics which convert step and direction input signals to high power currents and voltages to drive a step motor.



---

## Unipolar driver

Unipolar means that every coil end has one polarity only. A unipolar coil consists in fact of 2 coils. Alternating the current flows through each of these coils always in the same direction. Compared to a bipolar motor only half of the copper is used at time.

The motor phase winding must be center tapped. On the SAMOTRONIC101 this is already fixed on the board.

Often an additional Z-diode is used to ensure a fast current decay in the switched-off coil. This will give an increased motor torque especially at higher frequencies.

Torque graphs in this catalogue are measured with a 10 V diode.

## Bipolar Driver

Bipolar indicates that every coil end is bipolar, during driving it will be „+“ as well as „-“. Since every coil is fully used the motor has a higher torque compared to a unipolar one.

Very often a bipolar driver has a constant current drive capability (also called chopper). That will give an increased torque output at higher frequencies and a lower influence of temperature and supply voltage variations. Typical applications use the SAMOTRONIC102.

## Rotational speed

Revolutions of the motor per minute calculated from:

$$n = f \times \frac{\alpha \times 60}{360^\circ}$$

f = stepping frequency,  $\alpha$  = step angle.

## Detent torque (static)

Defines the maximum torque which can be applied to a deenergised motor without causing the motor to rotate. Catalogue specifications refer to the static detent torque.

## Holding torque

Defines the maximum torque with which an energized motor can be loaded without giving rise to a continuous rotary movement.

## Pull-in torque

Operation torque when switching on full step frequency at once, without a ramp.

## Pull-out torque

Operation torque when applying an acceleration / deceleration ramp.

## Load inertia moment

The sum of all the mass inertia moments occurring on the shaft of the stepping motor.

## Steps/rev

The number of steps per 360° rotation.

## Maximum operating torque

The maximum torque which a stepper motor without external mass inertia can generate without stepping losses.

# Synchronous Motors

## Rotational



Type	UAT3	UCM/UCR	UBR1/UBR2	UDR
Dimensions (mm)	∅ 20 × 17	∅ 28 × 24	∅ 36 × 21	∅ 48 × 24
Characteristics	<ul style="list-style-type: none"> <li>long life</li> <li>precision bearing</li> <li>standard 24VAC motor</li> <li><b>economic volume solution</b></li> </ul>	<ul style="list-style-type: none"> <li><b>standard modules</b></li> <li>customer specific interfaces</li> </ul>	<ul style="list-style-type: none"> <li><b>wide range of customized versions available</b></li> <li>up to 230 VAC supply voltage</li> </ul>	<ul style="list-style-type: none"> <li><b>compact reversible synchronous motor</b></li> </ul>
Voltage (V)	12–60	12–230	12–230	12–230
Speed 50 Hz (rpm)	600	250/500	250/500	500
60 Hz (rpm)	720	300/600	300/600	600
Pole number	10	24/12	24/12	12
Running torque (cNm)				
50 Hz	0.31/0.32	0.76–1.7	0.64–0.77	1.3
60 Hz	0.3/0.3	0.72–1.7	0.61–0.77	1.2
Power output (W)				
50 Hz	0.19/0.2	0.30–0.63	0.20–0.33	0.68
60 Hz	0.23/0.23	0.36–0.66	0.24–0.38	0.75
Gear combination	on request	D, M, B, F	D, M, B, F, V, J	D, M, B, F, V, J
Page	22	25/28	31/33	35

## Rotational



Type	UDS	UFM/UFU/UFR	UPU (SM6443/SM6444)
Dimensions (mm)	∅ 48 × 18.5	∅ 52 × 28 (56)	∅ 64 × 43
Characteristics	<ul style="list-style-type: none"> <li><b>simple to connect</b>, only two wires</li> <li>no capacitor</li> <li>uni-directional with anti-return mechanism</li> </ul>	<ul style="list-style-type: none"> <li><b>three-phase AC</b> operation possible</li> <li>for high power 2, 3 or 4 coils</li> </ul>	<ul style="list-style-type: none"> <li><b>most powerful</b> package with UGO/P/R gearboxes</li> </ul>
Voltage (V)	6–230	12–230	12–230
Speed 50 Hz (rpm)	500	250/375/500	375
60 Hz (rpm)	600	300/450/600	450
Pole number	12	24/12	16
Running torque (cNm)			
50 Hz	0.77	2.4–4.5	11.1–30.4
60 Hz	0.68	2.2–4.0	9.0–25.5
Power output (W)			
50 Hz	0.4	0.8–2.4	4.4–11.9
60 Hz	0.43	0.9–2.5	4.2–12.0
Gear combination	D, M, B, F, V, J	D, M, B, F, V, J (i ≤ 2k), O, P	O, P, R
Page	37	39/41/43	47

# Stepper Motors

## Rotational



Type	UAG3/4	UCD/UCB	UBD/UBB
Dimensions (mm)	∅ 20 × 17	∅ 28 × 24	∅ 36 × 21
Characteristics	<ul style="list-style-type: none"> <li>■ <b>economic volume</b> solution</li> </ul>	<ul style="list-style-type: none"> <li>■ <b>standard modules</b></li> <li>■ customer specific interfaces</li> </ul>	<ul style="list-style-type: none"> <li>■ <b>wide range</b> of customized versions available</li> </ul>
Step angle(°)	18	7.5/15	7.5/15
Holding torque (cNm)	0.53/0.39	1.1–2.4	0.85–1.6
Detent torque (cNm)	> 0.06	0.15–0.38	0.19–0.31
Winding	bipolar/unipolar	bipolar/unipolar	bipolar/unipolar
Gear combination	on request	D, M, B, F	D, M, B, F, V
Page	52	56/60	64/67

## Rotational



Type	UDB	UFD/UFB	UPJ (ST6443/ST6444)
Dimensions (mm)	∅ 48 × 24	∅ 52 × 28 (56)	∅ 64 × 43
Characteristics	<ul style="list-style-type: none"> <li>■ <b>compact reversible</b> 15° stepper motor</li> </ul>	<ul style="list-style-type: none"> <li>■ <b>two step angle</b> motor</li> </ul>	<ul style="list-style-type: none"> <li>■ <b>most powerful</b> package with STG/V gearboxes</li> </ul>
Step angle(°)	15	7.5/15	11.25
Holding torque (cNm)	2.2–2.7	3.7–8.8	30–45
Detent torque (cNm)	0.30	0.38–0.68	2–7
Winding	bipolar/unipolar	bipolar/unipolar	bipolar
Gear combination	D, M, B, F, V, J	D, M, B, F, V, J, O, P	O, P, R
Page	70	73/76	81

# Gearboxes



Type	UGD	UGM	UGB/UGF	UGY	UGW
Dimensions (mm)	55 × 62/65.6	51 × 65.2	58 × 81	∅ 20 x 12,7...27,7	∅ 34 x 62,4
Characteristics	<ul style="list-style-type: none"> <li>■ <b>established</b> plastic gears</li> <li>■ wide range of ratios</li> <li>■ gears rotate on hardened steel shafts</li> <li>■ optional integrated slipping clutches</li> </ul>	<ul style="list-style-type: none"> <li>■ <b>volume</b> metal and plastic spur gears</li> <li>■ hardened steel shafts included in plastic housing and metal plate</li> </ul>	<ul style="list-style-type: none"> <li>■ <b>robust</b> metal spur gears</li> <li>■ plastic primary gears</li> <li>■ die-cast aluminium housing</li> </ul>	<ul style="list-style-type: none"> <li>■ compact size</li> <li>■ plastic gears</li> </ul>	<ul style="list-style-type: none"> <li>■ <b>robust</b> metal spur gears</li> <li>■ plastic primary gears</li> <li>■ plastic housing</li> </ul>
Height	12/13	15	17	12,7...27,7	62,4
Max. torque (cNm) <sup>1)</sup>	32	100	250/500	30	450
Ratios	D: 4 <sup>1</sup> / <sub>6</sub> ...6.048.000	12 <sup>1</sup> / <sub>2</sub> ...4800	B: 41 <sup>2</sup> / <sub>3</sub> ...345.600 F: 4 <sup>1</sup> / <sub>6</sub> ...5000	4,4...370	541
Internal slipping clutch	optional	–	optional (UGB)	--	--
Standard shaft (mm)	∅ 4 × 10	∅ 4 × 10	∅ 8 × 12	∅ 4 × 14,8	∅ 8 × 21,3
Page	87	90	93/96	85	112

<sup>1)</sup> max. value, for higher ratios



Type	UGV	UGO/UGP (STG60/STG61)	UGJ	UGR (STG200)
Dimensions (mm)	70 × 70	∅ 65/68 × 68	65 × 107	70 × 130
Characteristics	<ul style="list-style-type: none"> <li>■ <b>solid</b> metal spur gears</li> <li>■ die-cast aluminium housing</li> </ul>	<ul style="list-style-type: none"> <li>■ <b>high performance</b> hardened steel spur gears</li> <li>■ low teeth profile</li> <li>■ optional interface plates for DC motors</li> <li>■ option additional housing for IP 65</li> </ul>	<ul style="list-style-type: none"> <li>■ the most extensive <b>gear ratio range</b></li> <li>■ medium torque two plate gear type with metal spur gears</li> </ul>	<ul style="list-style-type: none"> <li>■ <b>high performance</b> metal gear type</li> <li>■ robust aluminium twin plate design</li> <li>■ can be used with DC motors</li> </ul>
Height	17	29.8–38.2	28	38
Max. torque (cNm) <sup>1)</sup>	500	600	1500	2000
Ratios	8 <sup>1</sup> / <sub>3</sub> ...2000	6 <sup>1</sup> / <sub>4</sub> ...3750	4 <sup>1</sup> / <sub>6</sub> ...36 Mill. ≥ 2500 with UGD	6 <sup>1</sup> / <sub>4</sub> ...375
Internal slipping clutch	–	–	–	–
Standard shaft (mm)	∅ 8 × 12	∅ 8 × 22	∅ 12 × 20	∅ 12 × 35
Page	99	101	106	109

<sup>1)</sup> max. value, for higher ratios    <sup>2)</sup> depends on ratio

# Gearboxes with DC and BLDC Motors



Type	<b>UGM</b>	<b>UGB</b>	<b>UGF</b>	<b>UGO</b>	<b>UGP</b>
With	DC Motor PC280LG	DC Motor PC280LG	DC Motor HC485G	BLDC Motor E9I	DC Motor HC785G
Characteristics	<ul style="list-style-type: none"> <li>■ Plastics and metal spur gear wheels</li> <li>■ Bronze bearings</li> </ul>	<ul style="list-style-type: none"> <li>■ Plastics and metal spur gear wheels</li> <li>■ Bronze bearings</li> </ul>	<ul style="list-style-type: none"> <li>■ Metal spur gear wheels</li> <li>■ Bronze bearings</li> </ul>	<ul style="list-style-type: none"> <li>■ Metal spur gear wheels</li> <li>■ Bronze bearings</li> </ul>	<ul style="list-style-type: none"> <li>■ Metal spur gear wheels</li> <li>■ Bronze bearings</li> </ul>
Voltage	12 Vdc and 24 Vdc	12 Vdc and 24 Vdc	12 Vdc and 24 Vdc	24 Vdc	24 Vdc
Max. torque (cNm) <sup>1)</sup>	60	200	400	600	600
Ratios	120 ... 1500	150 ... 1500	125 ... 1200	18.75 ... 750	18.75 ... 750
Internal slipping clutch	–	optional	–	–	–
Standard shaft (mm)	∅ 4 × 10	∅ 8 × 12	∅ 8 × 12	∅ 8 × 25	∅ 8 × 25
Page	115	117	119	121	123

<sup>1)</sup> max. value, for higher ratios

# Synchronous Motors

## Linear



Type **UCC/UCK**

Dimensions (mm)  $\varnothing 28 \times 31$

- Characteristics
- linear motor using modules of the UC range
  - integrated non-rotational thread spindle

Travel (mm) 10/13

Voltage (V) 12–230

Thread pitch (mm) 1.0

Speed (mm/s)  
 50 Hz 4.16/8.33  
 60 Hz 5/10

Pole number 24/12

Max Force (N) 35

Page 126/130

# Stepper Motors

## Linear



Type **UAL**

**UCE/UCL**

Dimensions (mm)  $\varnothing 20 \times 30$

$\varnothing 28 \times 33$

- |   |  |
|---|--|
| <p>Characteristics</p> <ul style="list-style-type: none"> <li>■ small and compact design</li> <li>■ screw or bayonet flange</li> <li>■ integrated spindle with/without anti-rotation</li> </ul> | <ul style="list-style-type: none"> <li>■ linear motor using modules of the UC range</li> <li>■ integrated non-rotating threaded spindle</li> </ul> |
|---|--|

Travel (mm) 15

10/13

Travel per step (mm) 6–24

0.021/0.041

Thread pitch (mm) 0.5

1.0

Speed (mm/s)  
 at 200 Hz 4.16

4.16/8.33

Step angle (°)

7.5/15

Max. Force (N) 28

35

Page 135

139/144

# Electronics for Stepper Motors

## Driver Boards



Type **Samotronic101**    **Samotronic102**    **Evaluation-Kit 2**

Dimensions (mm)	55 × 40	84 × 54	metal case 164 × 130 × 45 (Euro-PCB)
Characteristics	<ul style="list-style-type: none"> <li>■ small unipolar board driver</li> </ul>	<ul style="list-style-type: none"> <li>■ small bipolar driver board</li> <li>■ flash controller</li> <li>■ optional customized software</li> </ul>	<ul style="list-style-type: none"> <li>■ tool for development, test and optimization of stepper drive systems</li> <li>■ windows-based software</li> <li>■ control and operation by computer</li> <li>■ quick parameter setup</li> <li>■ visualization of speed and position</li> <li>■ positioning sequences capability</li> </ul>
Driver	■ for unipolar motors	■ for bipolar motors	■ for unipolar and bipolar motors
Supply voltage	10–24 VDC	standard version 10–24 VDC enhanced version 10–42 VDC	3–48 VDC (unipolar motors), 8–48 VDC (bipolar motors) 24 VAC
Motor current	constant voltage drive	constant current drive (chopper controlled) adjustable via potentiometer	constant voltage drive and constant current drive (chopper controlled)
Step mode	full/half step	full/half step	full/half/micro step
Clock source	internal or external	internal or external	internal, programmable
Control inputs to	<ul style="list-style-type: none"> <li>■ inhibit internal clock</li> <li>■ inhibit motor current</li> <li>■ change direction of rotation</li> </ul>	<ul style="list-style-type: none"> <li>■ inhibit internal clock</li> <li>■ inhibit motor current</li> <li>■ change direction of rotation</li> </ul>	<ul style="list-style-type: none"> <li>■ 3 digital inputs</li> <li>■ 4 signal outputs</li> <li>■ 1 analog input 0...10 VDC</li> <li>■ 1 relay contact</li> </ul>
Configuration	via DIP-switch potentiometer	via DIP-switch potentiometer	RS 232, USB
Page	151	152	153

# Synchronous Motors Rotational



Dimensions

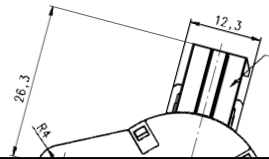

Circuit diagram

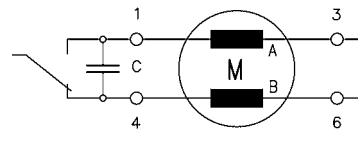



# UAT3

## UAT3

Dimensions (mm)	∅ 20 × 17.2
Voltage (V)	12-60
Speed (rpm) 50 Hz	600
60 Hz	720
Pole number	10
Running torque (cNm) 50 Hz	0.32 (standard magnet, stronger magnet on request)
60 Hz	0.3
Power output (W) 50 Hz	0.20 (standard magnet, stronger magnet on request)
60 Hz	0.23
Gear combination	on request



Note: Running torque = Pull-out torque (starting motor at no load, then torque increase)  
Running torque and Power output are minimum values, at rated voltage and motor temperature 23°C

## Standard Data

Climatic class	„wide-spread“ according to DIN IEC 60721-2-1 : 2015
Ambient temperature operation	°C -20 ... +60
Ambient temperature storage	°C -40 ... +100
Thermal resistance at f=0 R <sub>therm</sub>	47 K/W
Thermal class	130 (B) according to DIN EN 60085 : 2008
Approval	standard
Mounting	any position
Electrical connection	lead wires AWG28, insulation ∅ 0.82 mm
Protection	IP40 according to DIN EN 60529 : 2014
Weight	22 g
Rotor stalling	motor can be stopped when voltage is applied, without being overheated
Bearings	sintered bronze, self-lubricating

## Order Reference

Type	Synchronous Motor	UAT3	3	N	B4	R	E
Rotor shaft, mounting	0 centring 8 mm, mounting plate with screw M2						
	3 centring 8 mm, mounting plate with long holes						
	5 centring 8 mm, mounting plate (for clipping)						
	A centring 6 mm, mounting plate with screw M2						
	E centring 6 mm, mounting plate with long holes						
	G centring 6 mm, mounting plate (for clipping)						
Approval	N Approval Standard						
Voltage/Frequency	See next page						
Direction	reversible						
Cable	E cable 150 mm with Tyco connector CT 173977-4 (other on request)						

All specifications are representative only and maybe subject to variation. For confirmation of values, please contact Johnson Electric.  
Please also read "Saia Motors Important Notes" on catalog or at [www.johnsonelectric.com/SaiaMotorsNotes](http://www.johnsonelectric.com/SaiaMotorsNotes)

## Technical Data

Rated frequency	Hz	50	60
Speed n	rpm	600	720
Power consumption	W	1.4	1.4
Power output	W	0.20	0.23
Running torque	cNm	0.32	0.30 (standard magnet, stronger magnet on request)
Rotor inertia $J_R$	gcm <sup>2</sup>	0.26	
Detent torque $M_s$	mNm	> 0.6	
Tolerance of voltage		standard power supply system + 10% / - 10%	
Duty cycle		100%	
Winding temperature $T_{max}$	°C	130	
Direction of rotation		reversible	
Rated voltage $U_N$	V	24	24
Duty cycle	%	100	100
Resistance $R_{20}$	$\Omega$	430	430
Capacitor $C_n(50Hz)$	$\mu F$	3.3	2.7
Winding code	50Hz/60Hz	B4	G4

Circuit diagram Parallel circuit

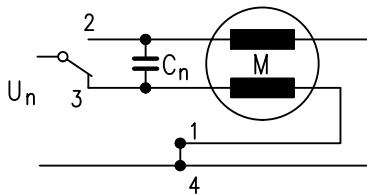

switch to  
2 = clockwise rotation  
3 = counter clockwise rotation

Dimensions

motor type	$\varnothing D$	
UAT30	$\varnothing 8$	0 -0.05
UAT3A	$\varnothing 6$	0 -0.05

motor type	$\varnothing D$	
UAT33	$\varnothing 8$	0 -0.05
UAT3E	$\varnothing 6$	0 -0.05

motor type	$\varnothing D$	
UAT35	$\varnothing 8$	0 -0.05
UAT3G	$\varnothing 6$	0 -0.05

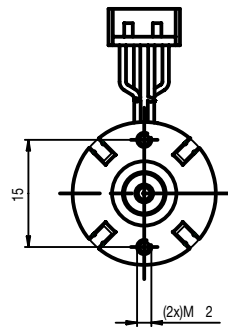

Use bolts with  
thread length 4mm max.  
Screw in torque 10cNm max.

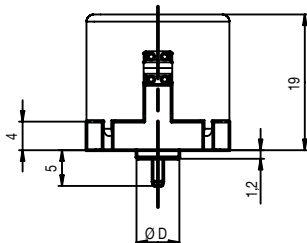
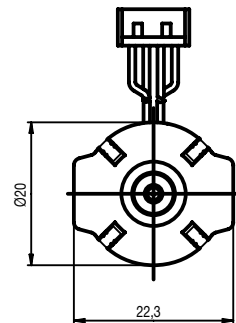
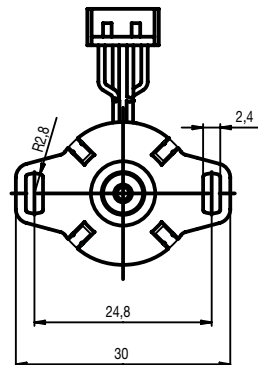

6-FRONT

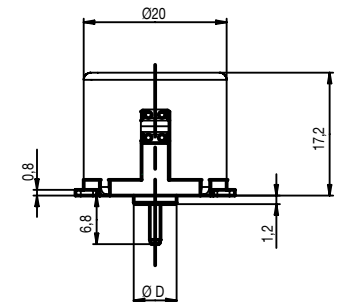
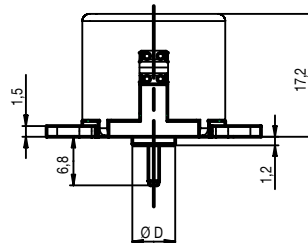

# UAT3

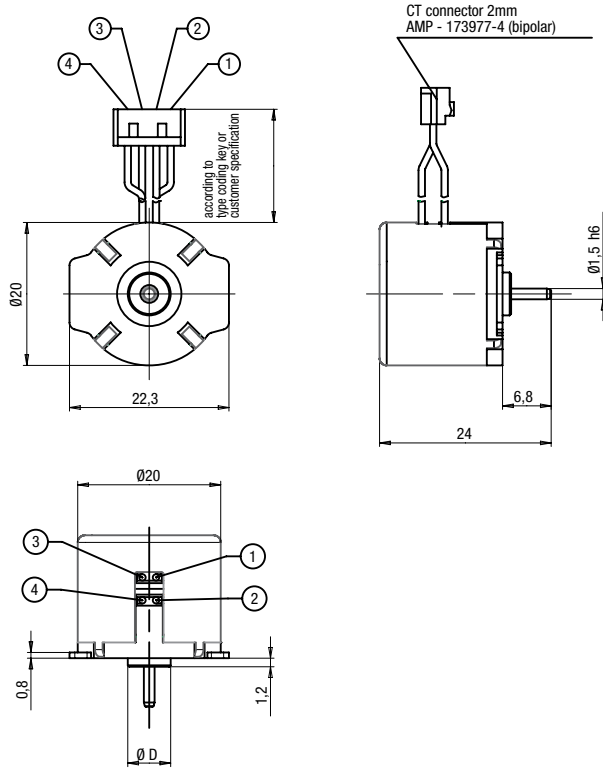

## UCM1/7

Dimensions (mm)	∅ 28 x 24
Voltage (V) *	12–230
Speed (rpm) 50 Hz	250
Pole number	24
Running torque (cNm) 50 Hz	1.15–1.7
60 Hz	1.15–1.7
Power output (W) 50 Hz	0.3–0.44
60 Hz	0.36–0.53
Gear combination	D, M, B, F

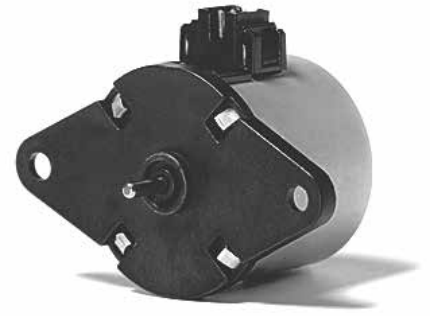

\* regard circuit diagram and connector type

Note: Running torque = Pull-out torque (starting motor at no load, then torque increase)  
Running torque and Power output are minimum values, at rated voltage and motor temperature 23°C

## Standard Data

Climatic class	„wide-spread“ according to DIN IEC 60721-2-1 : 2015
Ambient temperature operation	°C -15 ... +60
Ambient temperature storage	°C -20 ... +100
Thermal resistance at f=0 R <sub>therm</sub>	29 K/W
Thermal class	130 (B) according to DIN EN 60085 : 2008
Approval	standard
Mounting	any position
Electrical connection	connector type D or N
Protection	IP30 according to DIN EN 60529 : 2014
Weight	54 g
Rotor stalling	motor can be stopped when voltage is applied, without being overheated
Bearings	Sintered bronze, self-lubricating

## Order Reference

Type	Synchronous Motor	UCM	1	0	N	B4	R	D
Configuration	1 standard magnet 7 stronger magnet							
Rotor shaft, mounting	3 centring 8 mm, shaft 2.0 mm, screw plate 4 centring 8 mm, shaft 1.5 mm, screw plate 0 centring 8 mm, shaft 2.0 mm, clip 1 centring 8 mm, shaft 1.5 mm, clip	E centring 10 mm, shaft 2.0 mm, screw plate K centring 10 mm, shaft 1.5 mm, screw plate A centring 10 mm, shaft 2.0 mm, clip C centring 10 mm, shaft 1.5 mm, clip						
Approval	N Approval Standard							
Voltage/Frequency	see next pages							
Direction	R reversible							
Connection	D see next pages “Connection Types” and page 145 “Connection Types” for B N							

All specifications are representative only and maybe subject to variation. For confirmation of values, please contact Johnson Electric.  
Please also read “Saia Motors Important Notes” on catalog or at [www.johnsonelectric.com/SaiaMotorsNotes](http://www.johnsonelectric.com/SaiaMotorsNotes)

## Technical Data

		UCM1	UCM1	UCM7	UCM7
Rated frequency	Hz	50	60	50	60
Speed n	rpm	250	300	250	300
Detent torque $M_s$	cNm	0.18	0.18	0.36	0.36
Power consumption	VA	2.2	2.2	2.2	2.2
Rotor inertia $J_R$	gcm <sup>2</sup>	2.2	2.2	2.4	2.4
Tolerance of voltage		standard power supply system +10%/-10%			
Duty cycle		100%			
Winding temperature $T_{max}$	°C	130			
Direction of rotation		reversible			

### Specific Technical Data Lead Wire Versions (Connection N)

Performance	Running torque	cNm	1.15	1.15	1.45	1.45
	Power output	W	0.3	0.36	0.38	0.45
Capacitors	Rated voltage $U_N$	V	24	110		
	Duty cycle	%	100	100		
	Resistance $R_{20}$	$\Omega$	210	5000		
	Capacitor $C_n(50Hz)$	$\mu F/V \pm 10\%$	4.7/40	0.22/200		
	Winding code	50Hz/60Hz	B4/G4	C8/H8		

### Specific Technical Data Connector Versions (Connector D and B)

Performance	Running torque	cNm	1.4	1.4	1.7	1.7
	Power output	W	0.36	0.44	0.44	0.53
Capacitors	Rated voltage $U_N$	V	12	24		
	Duty cycle	%	100	100		
	Resistance $R_{20}$	$\Omega$	53	210		
	Capacitor $C_{50}$	$\mu F/V \pm 10\%$	18/20	4.7/40		
	Winding code		B1	B4		

Circuit diagram Parallel circuit 12 V, 24 V, 48 V

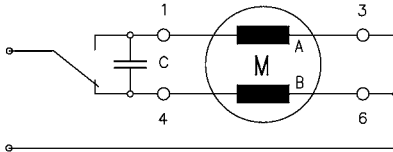

Parallel circuit 230 V (only for lead wire versions) with 110 V motor and resistor  $R_V$

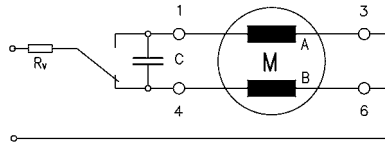

Parallel circuit 230 V (only for lead wire versions) with 110 V motor and capacitor  $C_V$

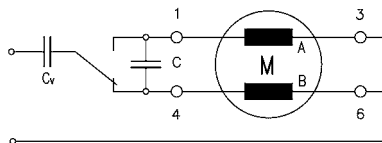

switch to

- 1 clockwise rotation
- 4 counter clockwise rotation
- 6 counter clockwise rotation (for series circuit)

Series resistor  $R_V = 5.6 \text{ k}\Omega$ , 3 W

Series capacitor  $C_V = 0.33 \text{ }\mu\text{F}$ , 250 VAC

Dimensions Version with Connector D

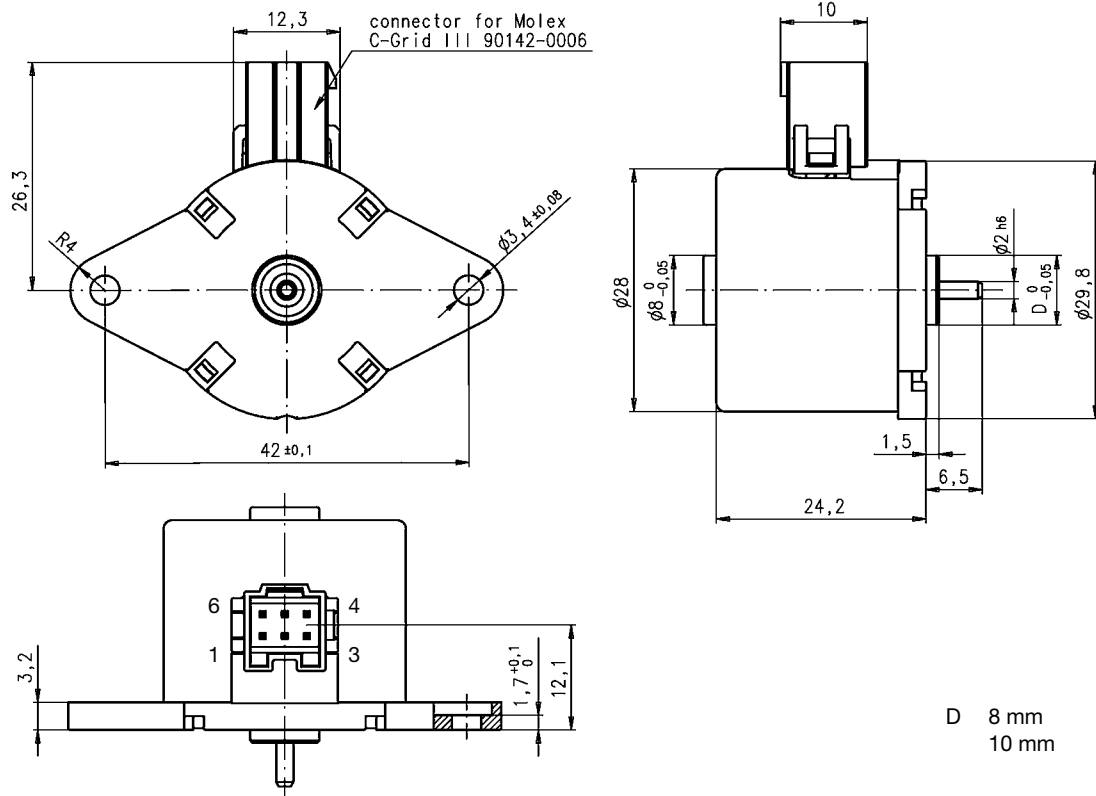

Version with Connection N

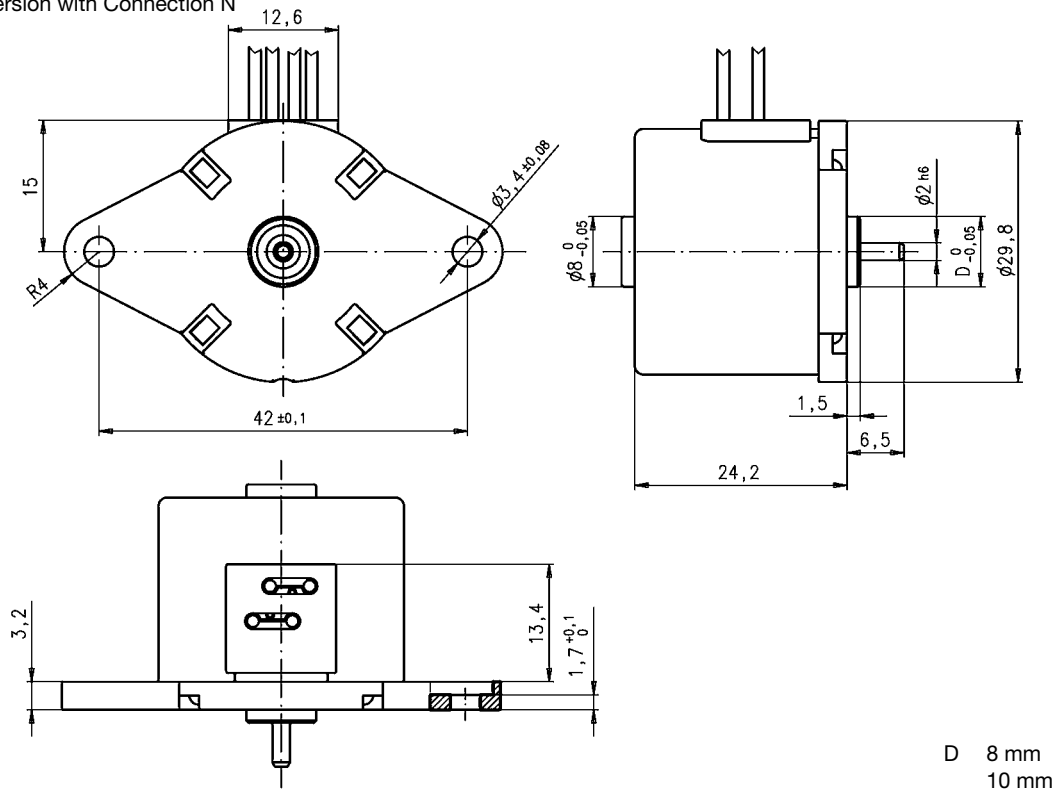

## UCR1/7

Dimensions (mm) Ø 28 x 24

Voltage (V) \* 12–230

Speed (rpm) 50 Hz 500

Pole number 12

Running torque  
(cNm) 50 Hz 0.76–1.2  
60 Hz 0.72–1.05

Power output (W)  
50 Hz 0.40–0.63  
60 Hz 0.45–0.66

Gear combination D, M, B, F

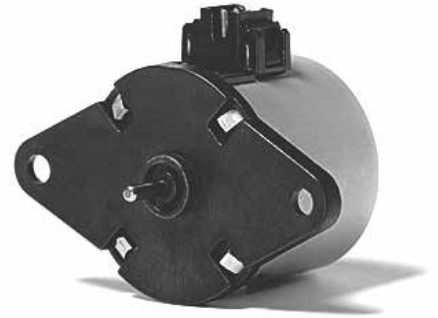

\* regard circuit diagram and connector type

Note: Running torque = Pull-out torque (starting motor at no load, then torque increase)  
Running torque and Power output are minimum values, at rated voltage and motor temperature 23°C

### Standard Data

Climatic class	wide-spread according to DIN IEC 60721-2-1 : 2015
Ambient temperature operation	°C -15 ... +60
Ambient temperature storage	°C -20 ... +100
Thermal resistance at f=0 R <sub>therm</sub>	29 K/W
Thermal class	130 (B) according to DIN EN 60085 : 2008
Approval	standard
Mounting	any position
Electrical connection	connector type D or N
Protection	IP30 according to DIN EN 60529 : 2014
Weight	54 g
Rotor stalling	motor can be stopped when voltage is applied, without being overheated
Bearings	Sintered bronze, self-lubricating

### Order Reference

Type	Synchronous Motor	UCR	1	0	N	B4	R	D
Configuration	1 standard magnet 7 stronger magnet							
Rotor shaft, mounting	3 centring 8 mm, shaft 2.0 mm, screw plate 4 centring 8 mm, shaft 1.5 mm, screw plate 0 centring 8 mm, shaft 2.0 mm, clip 1 centring 8 mm, shaft 1.5 mm, clip	E K A C						
Approval	N Approval Standard							
Voltage/Frequency	see next pages							
Direction	R reversible							
Connection	D see next pages "Connection Types" and page 145 "Connection Types" for B N Cable							

All specifications are representative only and maybe subject to variation. For confirmation of values, please contact Johnson Electric.  
Please also read "Saia Motors Important Notes" on catalog or at [www.johnsonelectric.com/SaiaMotorsNotes](http://www.johnsonelectric.com/SaiaMotorsNotes)

## Technical Data

		UCR1	UCR1	UCR7	UCR7
Rated frequency	Hz	50	60	50	60
Speed n	rpm	500	600	500	600
Detent torque $M_s$	cNm	0.2	0.2	0.45	0.45
Power consumption	VA	2.4	2.5	2.3	2.4
Rotor inertia $J_R$	gcm <sup>2</sup>	2.1	2.1	2.4	2.4
Tolerance of voltage		standard power supply system +10%/-10%			
Duty cycle		100%			
Winding temperature $T_{max}$	°C	130			
Direction of rotation		reversible			

### Specific Technical Data Lead Wire Versions (Connection N)

Performance	Running torque	cNm	0.76	0.72	0.93	0.85
	Power output	W	0.40	0.45	0.49	0.53
Capacitors	Rated voltage $U_N$	V	12	24	110	
	Duty cycle	%	100	100	100	
	Resistance $R_{20}$	$\Omega$	60	230	5500	
	Capacitor $C_n(50Hz)$	$\mu F/V \pm 10\%$	22/20	5.6/40	0.27/200	
	Winding code	50Hz/60Hz	B1/G1	B4/G4	C8/H8	

### Specific Technical Data Connector Versions (Connector D and B)

Performance	Running torque	cNm	0.94	0.87	1.2	1.05
	Power output	W	0.50	0.54	0.63	0.66
Capacitors	Rated voltage $U_N$	V	12	24		
	Duty cycle	%	100	100		
	Resistance $R_{20}$	$\Omega$	59	230		
	Capacitor $C_n(50Hz)$	$\mu F/V \pm 10\%$	22/20	5.6/40		
	Winding code	50Hz/60Hz	B1	B4		

Circuit diagram Parallel circuit 12 V, 24 V, 48 V, 110 V

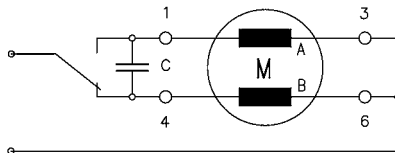

Parallel circuit 230 V (only for lead wire versions) with 110 V motor and resistor  $R_v$

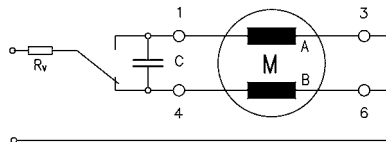

switch to

- 1 clockwise rotation
- 4 counter clockwise rotation
- 6 counter clockwise rotation (for series circuit)

Parallel circuit 230 V (only for lead wire versions) with 110 V motor and capacitor  $C_v$

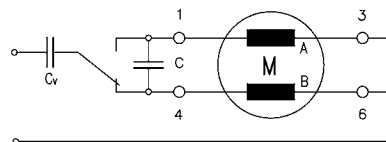

Series resistor  $R_v = 5.6 \text{ k}\Omega$ , 3 W

Series capacitor  $C_v = 0.33 \text{ }\mu\text{F}$ , 250 VAC



## Dimensions Version with Connector D

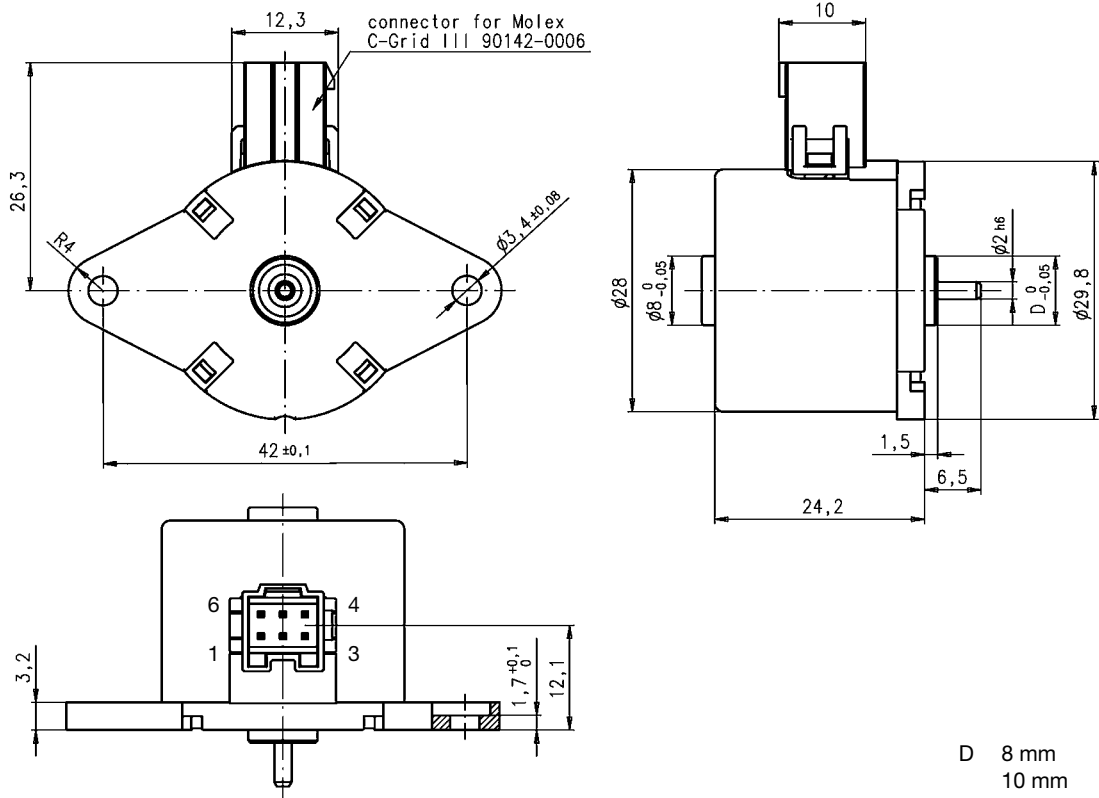

## Version with Connection N

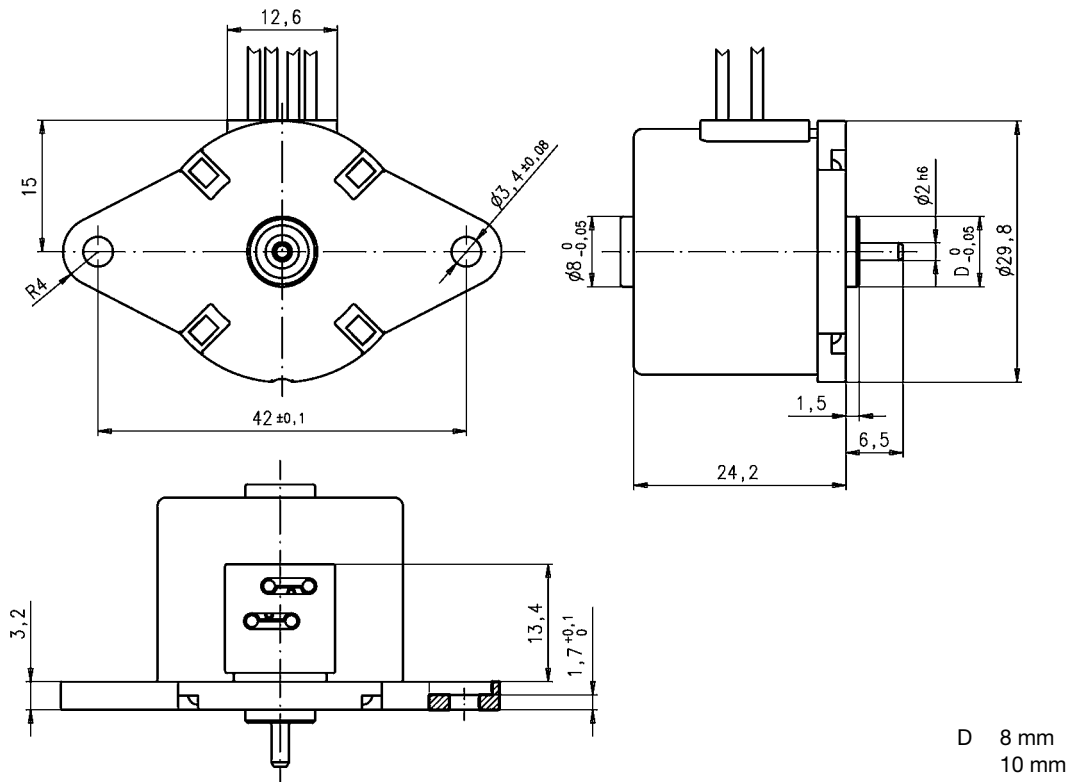

## UBR1

Dimensions (mm) Ø 36 x 21

Voltage (V) 12–230

Speed (rpm) 50 Hz 250  
60 Hz 300

Pole number 24

Running torque  
(cNm) 50 Hz 0.77  
60 Hz 0.77

Power output (W)  
50 Hz 0.20  
60 Hz 0.24

Gear combination D, M, B, F, V, J



Note: Running torque = Pull-out torque (starting motor at no load, then torque increase)  
Running torque and Power output are minimum values, at rated voltage and motor temperature 23°C

## Standard Data

Climatic class	wide-spread according to DIN IEC 60721-2-1 : 2015
Ambient temperature operation	°C -15...+55
Ambient temperature storage	°C -20...+100
Thermal resistance at f=0 R <sub>therm</sub>	27 K/W
Thermal class	105 (A) according to DIN EN 60085 : 2008
Approval	standard (UL/CSA on request)
Mounting	any position
Electrical connection	cable
Protection	IP40 according to DIN EN 60529 : 2014
Weight	60 g
Rotor stalling	motor can be stopped when voltage is applied, without being overheated
Bearings	sintered bronze, self-lubricating
Electric strength	according to DIN EN 60034-1/DIN EN 60335-1

## Order Reference

Type	Synchronous Motor	UBR1	0	N	B4	R	E
Rotor shaft, mounting	0 centring 8 mm, shaft 2.0 mm, clip 1 centring 8 mm, shaft 1.5 mm, clip 3 centring 8 mm, shaft 2.0 mm, screw plate 4 centring 8 mm, shaft 1.5 mm, screw plate	A centring 10 mm, shaft 2.0 mm, clip C centring 10 mm, shaft 1.5 mm, clip E centring 8 mm, shaft 2.0 mm, screw plate K centring 10 mm, shaft 1.5 mm, screw plate					
Approval	N Approval Standard						
Voltage/Frequency	See next page						
Direction	reversible						
Cable	E cable 150 mm (other on request)						

All specifications are representative only and maybe subject to variation. For confirmation of values, please contact Johnson Electric.  
Please also read "Saia Motors Important Notes" on catalog or at [www.johnsonelectric.com/SaiaMotorsNotes](http://www.johnsonelectric.com/SaiaMotorsNotes)

## Technical Data

Rated frequency	Hz	50	60			
Speed n	rpm	250	300			
Power consumption	W	1.3	1.3			
Power output	W	0.20	0.24			
Running torque	cNm	0.77	0.77			
Rotor inertia $J_R$	gcm <sup>2</sup>	2.8				
Detent torque $M_s$	cNm	0.19	0.19			
Tolerance of voltage		standard power supply system + 10% / - 10%				
Winding temperature $T_{max}$	°C	105				
Direction of rotation		reversible				
Rated voltage $U_N$	V	12	24	48	110	230
Duty cycle	%	100	100	100	100	100
Resistance $R_{20}$	Ω	104	385	1580	9160	11800
Capacitor $C_n$ (50Hz, 60Hz)	μF/V ±10%	12/20	3.3/34	0.82/70	0.15/170	0.22;0.12/170
Winding code	50Hz/60Hz	B1/G1	B4/G4	C1/H1	D1/J1	D5/J5

Circuit diagram Parallel circuit 12V, 24V, 48V, 110V

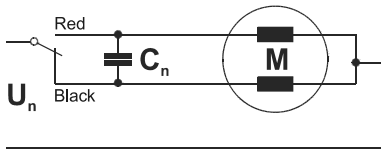

Parallel circuit 230V

$R_v=12k\ \Omega$  / 1.5W for motors with resistance  $R_{20}=9160\ \Omega$ , code D1/J1

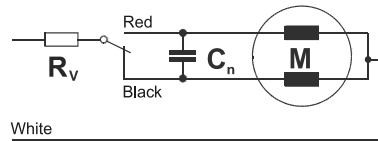

Series circuit 230V (for motors with resistance  $R_{20}=11800\ \Omega$ )

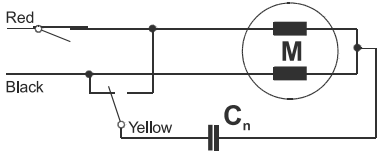

Parallel circuit 230V

$C_v=0.18\ \mu F$  (50Hz) /  $0.15\ \mu F$  (60Hz) / 200Vac with resistance  $R_{20}=9160\ \Omega$

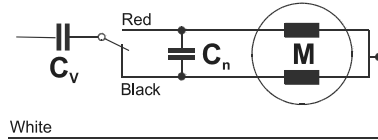

Red = clockwise rotation  
Black = counter clockwise rotation

Dimensions Mounting with screw plate

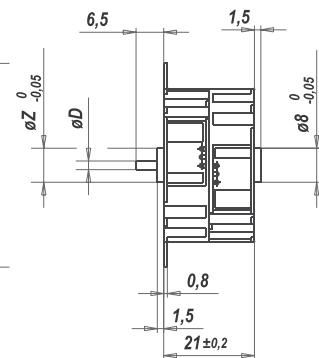
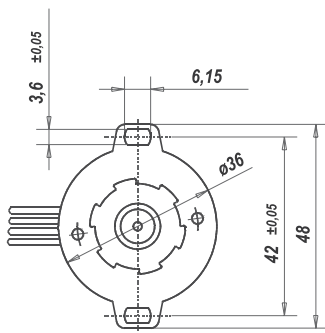

Mounting with snap-on clip  
(item no. 4199 48230)

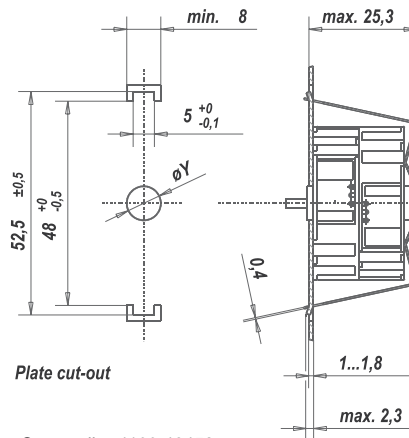

Screw clip: 4199 48450

øD Rotor shaft  
ø 2 h6  
ø 1.5 js8

øZ	øY
8	8F8
10	10F8

# UBR2

## UBR2

Dimensions (mm)  $\varnothing$  36 x 21

Voltage (V) 12–230

Speed (rpm) 50 Hz 500  
60 Hz 600

Pole number 12

Running torque (cNm) 50 Hz 0.64  
60 Hz 0.61

Power output (W) 50 Hz 0.33  
60 Hz 0.38

Gear combination D, M, B, F, V, J



Note: Running torque = Pull-out torque (starting motor at no load, then torque increase)  
Running torque and Power output are minimum values, at rated voltage and motor temperature 23°C

## Standard Data

Climatic class	wide-spread according to DIN IEC 60721-2-1 : 2015
Ambient temperature operation	°C -15...+55
Ambient temperature storage	°C -20...+100
Thermal resistance at f=0 R <sub>therm</sub>	27 K/W
Thermal class	105 (A) according to DIN EN 60085 : 2008
Approval	standard (UL/CSA on request)
Mounting	any position
Electrical connection	cable
Protection	IP40 according to DIN EN 60529 : 2014
Weight	60 g
Rotor stalling	motor can be stopped when voltage is applied, without being overheated
Bearings	sintered bronze, self-lubricating
Electric strength	according to DIN EN 60034-1/DIN EN 60335-1

## Order Reference

Type	Synchronous Motor		UBR2	0	N	B4	R	E
Rotor shaft, mounting	0	centring 8 mm, shaft 2.0 mm, clip	A	centring 10 mm, shaft 2.0 mm, clip				
	1	centring 8 mm, shaft 1.5 mm, clip	C	centring 10 mm, shaft 1.5 mm, clip				
	3	centring 8 mm, shaft 2.0 mm, screw plate	E	centring 10 mm, shaft 2.0 mm, screw plate				
	4	centring 8 mm, shaft 1.5 mm, screw plate	K	centring 10 mm, shaft 1.5 mm, screw plate				
Approval	N	Approval Standard						
Voltage/Frequency		See next page						
Direction		reversible						
Cable	E	cable 150 mm (other on request)						

All specifications are representative only and maybe subject to variation. For confirmation of values, please contact Johnson Electric.  
Please also read "Saia Motors Important Notes" on catalog or at [www.johnsonelectric.com/SaiaMotorsNotes](http://www.johnsonelectric.com/SaiaMotorsNotes)

## Technical Data

Rated frequency	Hz	50	60			
Speed n	rpm	500	600			
Power consumption	W	1.6	1.6			
Power output	W	0.33	0.38			
Running torque	cNm	0.64	0.61			
Rotor inertia $J_R$	gcm <sup>2</sup>	2.8				
Detent torque $M_s$	cNm	0.21				
Tolerance of voltage		standard power supply system + 10% / - 10%				
Winding temperature $T_{max}$	°C	105				
Direction of rotation		reversible				
UBR2 Rated voltage $U_N$	V	12	24	48	110	230
Duty cycle	%	100	100	100	100	100
Resistance $R_{20}$	$\Omega$	87	344	1370	7650	12600
Capacitor $C_n$ (50Hz, 60Hz)	$\mu F/V \pm 10\%$	15/20	3.9/40	1/70	0.18/170	0.27;0.22/170
Winding code	50Hz/60Hz	B1/G1	B4/G4	C1/H1	D1/J1	D5/J5
UBR3 Rated voltage $U_N$	V	12	24	48		
Duty cycle	%	100	100	100		
Resistance $R_{20}$	$\Omega$	87	344	1370		
Capacitor $C_n$ (50Hz)	$\mu F/V \pm 10\%$	15/20	3.9/40	1/70		
Winding code	50Hz/60Hz	B1/G1	B4/G4	C1/H1		

Circuit diagram Parallel circuit 12V, 24V, 48V, 110V

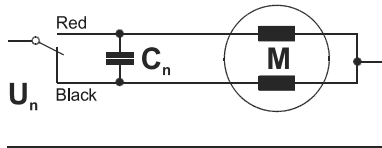

Parallel circuit 230V

$R_v = 8.2k \Omega / 1.5W$  for motors with resistance  $R_{20} = 7650 \Omega$ , code D1/J1

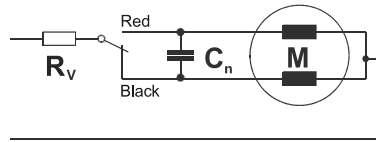

Series circuit 230V (for motors with resistance  $R_{20} = 12600 \Omega$ )

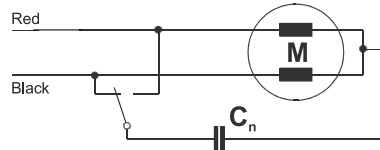

Parallel circuit 230V

$C_v = 0.22 \mu F$  (50Hz) /  $0.18 \mu F$  (60Hz) / 200 Vac with resistance  $R_{20} = 7650 \Omega$

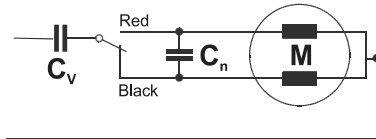

Red = clockwise rotation  
Black = counter clockwise rotation

Dimensions Mounting with screw plate

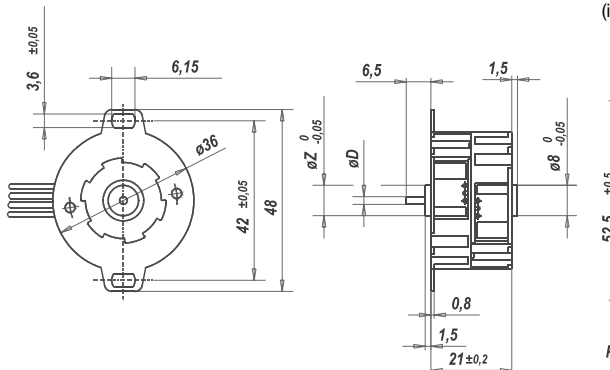

Mounting with snap-on clip (item no. 4199 48230)

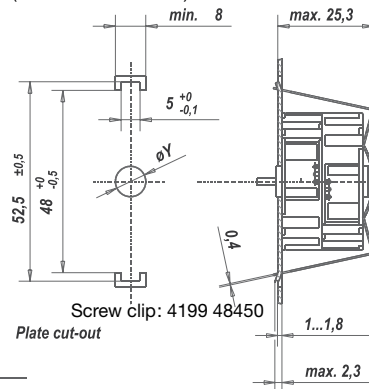

$\varnothing D$  Rotor shaft  
 $\varnothing 2$  h6  
 $\varnothing 1.5$  js8  
 $\varnothing Z$   $\varnothing Y$   
 8 8F8  
 10 10F8

## UDR1

Dimensions (mm)  $\varnothing$  48 x 24

Voltage (V) 12–230

Speed (rpm) 50 Hz 500  
60 Hz 600

Pole number 12

Running torque (cNm) 50 Hz 1.3  
60 Hz 1.2

Power output (W) 50 Hz 0.68  
60 Hz 0.75

Gear combination D, M, B, F, V, J

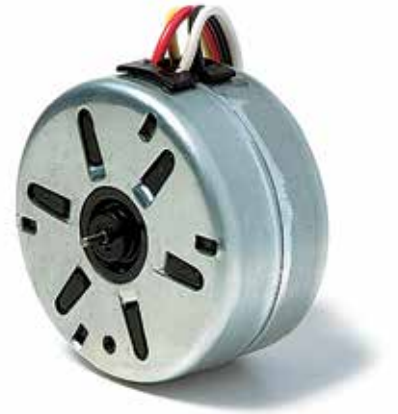

Note: Running torque = Pull-out torque (starting motor at no load, then torque increase)  
Running torque and Power output are minimum values, at rated voltage and motor temperature 23°C

## Standard Data

Climatic class	wide-spread according to DIN IEC 60721-2-1 : 2015
Ambient temperature operation	°C -15...+60
Ambient temperature storage	°C -20...+100
Thermal resistance at f=0 R <sub>therm</sub>	18 K/W
Thermal class	105 (A) according to DIN EN 60085 : 2008
Approval	standard/UL/CSA
Mounting	any position
Electrical connection	cabl
Protection	IP30 according to DIN EN 60529 : 2014
Weight	132 g
Rotor stalling	motor can be stopped when voltage is applied, without being overheated
Bearings	sintered bronze, self-lubricating
Electric strength	according to DIN EN 60034-1/DIN EN 60335-1

## Order Reference

Type	Synchronous Motor	UDR1	00	N	B4	R	N
Rotor shaft, mounting	0 centring 8 mm, shaft 1.5 mm, clip 1 centring 8 mm, shaft 2.0 mm, clip						
Approval	N Approval Standard U Approval UL/CSA						
Voltage/Frequency	See next page						
Direction	reversible						
Cable	N cable 150 mm (other on request)						

All specifications are representative only and maybe subject to variation. For confirmation of values, please contact Johnson Electric.  
Please also read "Saia Motors Important Notes" on catalog or at [www.johnsonelectric.com/SaiaMotorsNotes](http://www.johnsonelectric.com/SaiaMotorsNotes)

## Technical Data

Rated frequency	Hz	50	60			
Speed n	rpm	500	600			
Power consumption	W	2.1	2.2			
Power output	W	0.68	0.75			
Running torque	cNm	1.3	1.2			
Rotor inertia $J_R$	gcm <sup>2</sup>	6.3				
Detent torque $M_s$	cNm	0.30				
Tolerance of voltage		standard power supply system + 10% / - 10%				
Winding temperature $T_{max}$	°C	105				
Direction of rotation		reversible				
Rated voltage $U_N$	V	12	24	48	110-120	230
Duty cycle	%	100	100	100	100	100
Resistance $R_{20}$	$\Omega$	50	200	800	5000	19000
Capacitor $C_n$ (50Hz, 60Hz)	$\mu F/V \pm 10\%$	27;22/20	6.8;4.7/34	1.5/70	0.27/170	0.068/340
Winding code	50Hz/60Hz	B1/G1	B4/G4	C1/H1	D1/J1	D5/J5

Circuit diagram Parallel circuit

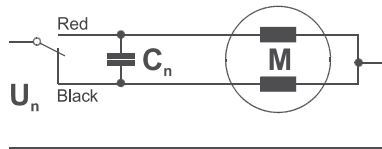

Red = clockwise rotation  
Black = counter clockwise rotation

Dimensions

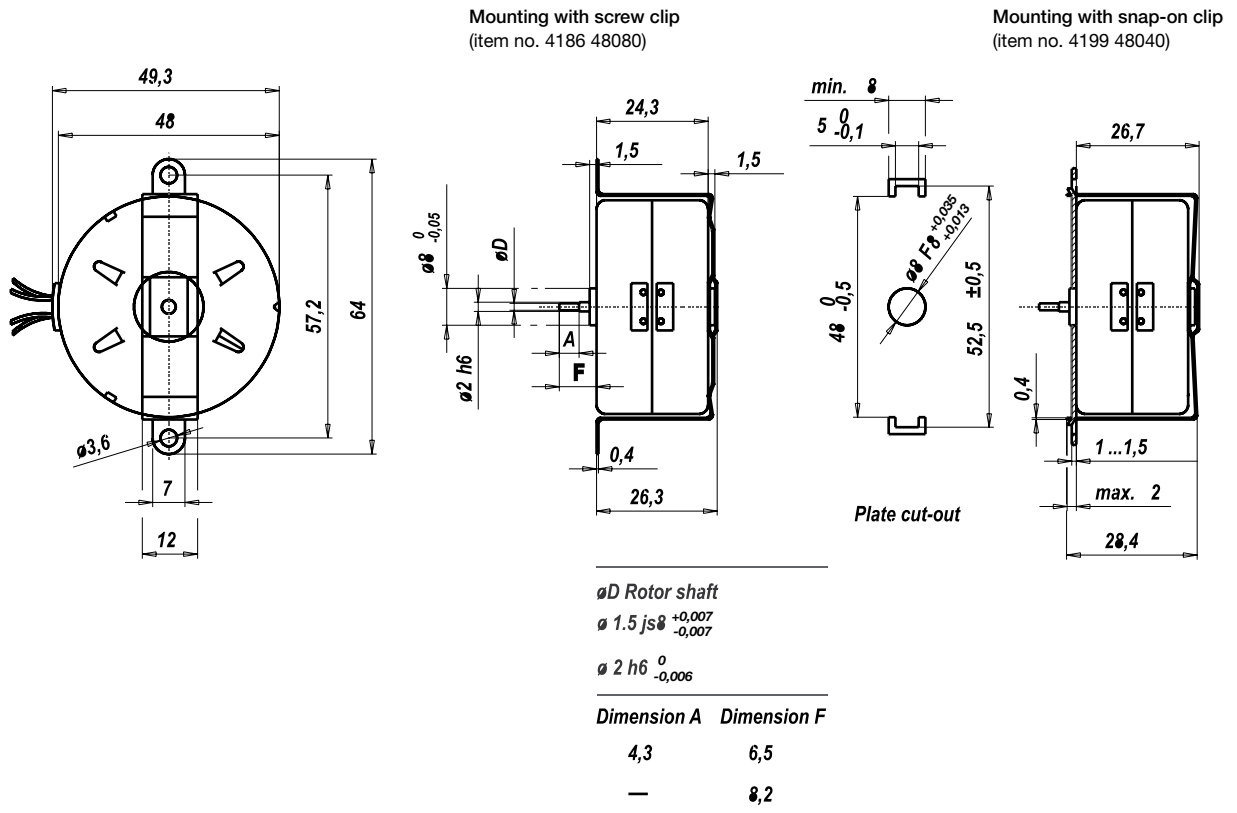

## UDS1

Dimensions (mm)	∅ 48 x 18.5
Voltage (V)	6-230
Speed (rpm) 50 Hz	500
60 Hz	600
Pole number	12
Running torque (cNm) 50 Hz	0.77
60 Hz	0.68
Power output (W) 50 Hz	0.40
60 Hz	0.43
Gear combination	D, M, B, F, V, J



Note: Running torque = Pull-out torque (starting motor at no load, then torque increase)  
Running torque and Power output are minimum values, at rated voltage and motor temperature 23°C

## Standard Data

Climatic class	wide-spread according to DIN IEC 60721-2-1 : 2015
Ambient temperature operation	°C -15...+60
Ambient temperature storage	°C -20...+100
Thermal resistance at f=0 R <sub>therm</sub>	17 K/W
Thermal class	105 (A) according to DIN EN 60085 : 2008 for approval standard 130 (B) according to DIN EN 60085 : 2008 for approval UL/CSA
Approval	standard/UL/CSA
Mounting	any position
Electrical connection	cable
Protection	IP40 according to DIN EN 60529 : 2014
Weight	102 g
Rotor stalling	motor can be stopped when voltage is applied, without being overheated
Bearings	plastic, self-lubricating
Electric strength	according to DIN EN 60034-1/DIN EN 60335-1

## Order Reference

Type	Synchronous Motor	UDS1	0	N	B4	R	N
Rotor shaft, mounting	0 centring 8 mm, shaft 1.5 mm, clip 1 centring 8 mm, shaft 2.0 mm, clip						
Approval	N Approval Standard U Approval UL/CSA						
Voltage/Frequency	See next page						
Direction	R clockwise rotation L Counter-clockwise rotation						
Cable	N cable 150 mm (other on request)						

All specifications are representative only and maybe subject to variation. For confirmation of values, please contact Johnson Electric.  
Please also read "Saia Motors Important Notes" on catalog or at [www.johnsonelectric.com/SaiaMotorsNotes](http://www.johnsonelectric.com/SaiaMotorsNotes)



## Technical Data

Rated frequency	Hz	50	60
Speed n	rpm	500	600
Power consumption*	W	2.4	1.8
Power output	W	0.40	0.43
Running torque	cNm	0.77	0.68
Rotor inertia J <sub>R</sub>	gcm <sup>2</sup>	11	
Detent torque M <sub>s</sub>	cNm	0.23 (in direction of rotation)	
Tolerance of voltage		standard power supply system + 10% / - 10%	
Winding temperature T <sub>max</sub>	°C	105 for approval Standard (N) 130 for approval UL/CSA	

Direction of rotation: clockwise or counter-clockwise

UDS1	Rated voltage U <sub>N</sub>	V	6	12	24	36	42	48	60	110	110-120	230	110/230	24/48
	Duty cycle	%	100	100	100	100	100	100	100	100	100	100	100	100
	Resistance R <sub>20</sub>	Ω	5.5	24	78	193	285	330	500	1830	1830	7500	2180/5500	105/260
	Winding code		A6/F6	B1/G1	B4/G4	B6/G6	B8/G8	C1/H1	C2/H2	C8/H8	D1/J1	D5/J5	R1/S1	R4/S4
UDS1 Approval U	Rated voltage U <sub>N</sub>	V	6	12	24	48	100	110	110-120	230	110/230	24/48		
	Duty cycle	%	100	100	100	100	100	100	100	100	100	100		
	Resistance R <sub>20</sub>	Ω	5.5	24	78	330	1350	1830	1830	7500	2180/5500	105/260		
	Winding code		A6/F6	B1/G1	B4/G4	C1/H1	C7/H7	C8/H8	D1/J1	D5/J5	R1/S1	R4/S4		
UDS3	Rated voltage U <sub>N</sub>	V	6	12	24	36	42	48	60	110	230	110/230	24/48	
	Duty cycle	%	100	100	100	100	100	100	100	100	100	100	100	
	Resistance R <sub>20</sub>	Ω	5.5	24	78	193	285	330	500	1830	7500	2180/5500	105/260	
	Winding code		A6/F6	B1/G1	B4/G4	B6/G6	B8/G8	C1/H1	C2/H2	C8/H8	D5/J5	R1/S1	R4/S4	
UDS4	Rated voltage U <sub>N</sub>	V	12	24	42	48	110-120	230						
	Duty cycle	%	100	100	100	100	100	100						
	Resistance R <sub>20</sub>	Ω	23	98	322	390	2200	8700						
	Winding code		B1/G1	B4/G4	B8/G8	C1/H1	D1/J1	D5/J5						

\*can vary for different windings (rated voltages)

### Dimensions

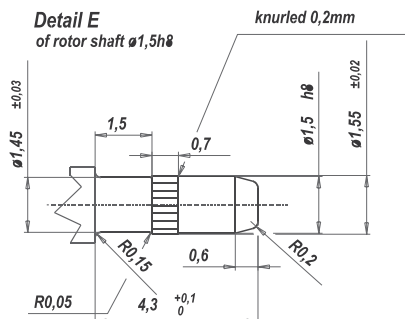
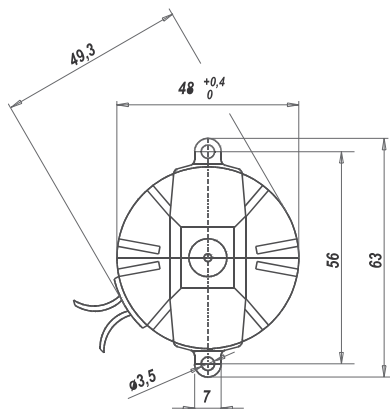

Mounting with screw clip  
(item no. 4186 48200)

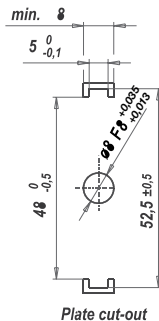
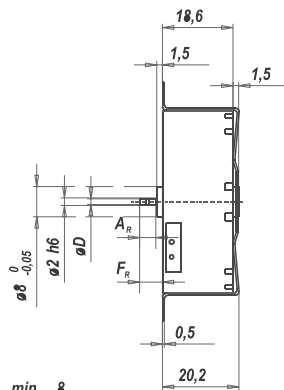

Mounting with snap-on clip  
(item no. 4199 48000)

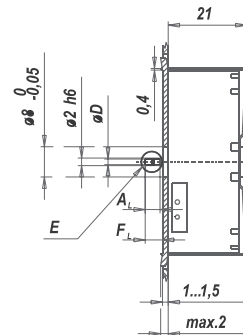

∅D Rotor shaft	Clockwise		counter clockwise	
	Dim. A <sub>R</sub>	Dim. F <sub>R</sub>	Dim. A <sub>L</sub>	Dim. F <sub>L</sub>
1,5h8 <sup>0</sup> <sub>-0,014</sub>	4,3 <sup>+0,1</sup>	6,05	4,3 <sup>+0,1</sup>	6,45
2h6 <sup>0</sup> <sub>-0,006</sub>	—	6,05	—	6,45

## UFM1

Dimensions (mm)	Ø 52 x 28
Voltage (V)	12–230
Speed (rpm) 50 Hz	250
60 Hz	300
Pole number	24
Running torque (cNm)	
50 Hz	3.2
60 Hz	3.0
Power output (W)	
50 Hz	0.8
60 Hz	0.9
Gear combination	D, M, B, F, V, J (i ≤ 2k), O, P

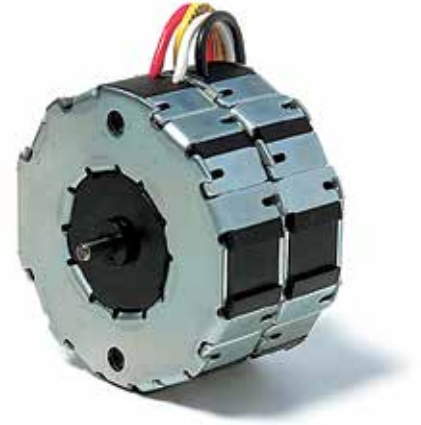

Note: Running torque = Pull-out torque (starting motor at no load, then torque increase)  
Running torque and Power output are minimum values, at rated voltage and motor temperature 23°C

## Standard Data

Climatic class	wide-spread according to DIN IEC 60721-2-1 : 2015
Ambient temperature operation	°C -15...+55
Ambient temperature storage	°C -20...+100
Thermal resistance at f=0 R <sub>therm</sub>	13 K/W
Thermal class	105 (A) according to DIN EN 60085 : 2008 (130 / B on request)
Approval	standard (UL/CSA on request)
Mounting	any position
Electrical connection	lead wires AWG22, insulation Ø 1.72 ± 0.08 mm
Protection	IP40 according to DIN EN 60529 : 2014
Weight	180 g
Rotor stalling	motor can be stopped when voltage is applied, without being overheated
Bearings	sintered bronze, self-lubricating
Electric strength	according to DIN EN 60034-1/DIN EN 60335-1

## Order Reference

Type	Synchronous Motor	UFM1	0	N	B4	R	N
Rotor shaft, mounting	0 centring 8 mm, shaft 3.0 mm, clip	E centring 10 mm, shaft 3.0 mm, screw plate					
	1 centring 8 mm, shaft 2.0 mm, clip	K centring 10 mm, shaft 2.0 mm, screw plate					
	2 centring 8 mm, shaft 1.5 mm, clip	M centring 10 mm, shaft 1.5 mm, screw plate					
	3 centring 8 mm, shaft 3.0 mm, screw plate	B centring 10 mm, shaft 3.0 mm, clip					
	4 centring 8 mm, shaft 2.0 mm, screw plate	A centring 10 mm, shaft 2.0 mm, clip					
	5 centring 8 mm, shaft 1.5 mm, screw plate	C centring 10 mm, shaft 1.5 mm, clip					
Approval	N Approval Standard						
Voltage/Frequency	See next page						
Direction	reversible						
Cable	N cable 150 mm (other on request)						

All specifications are representative only and maybe subject to variation. For confirmation of values, please contact Johnson Electric.  
Please also read "Saia Motors Important Notes" on catalog or at [www.johnsonelectric.com/SaiaMotorsNotes](http://www.johnsonelectric.com/SaiaMotorsNotes)

## Technical Data

Rated frequency	Hz	50	60			
Speed n	rpm	250	300			
Power consumption	W	4	3.1			
Power output	W	0.8	0.9			
Running torque	cNm	3.2	3.0			
Rotor inertia $J_R$	gcm <sup>2</sup>	14.4				
Detent torque $M_s$	cNm	0.38				
Tolerance of voltage		standard power supply system + 10% / - 10%				
Winding temperature $T_{max}$	°C	105				
Direction of rotation		reversible				
Rated voltage $U_N$	V	12	24	48	110-120	230
Duty cycle	%	100	100	100	100	100
Resistance $R_{20}$	$\Omega$	15	59	240	1390	5690
Capacitor $C_n$ (50Hz, 60Hz)	$\mu F/V \pm 10\%$	39;33/20	10;8.2/45	2.2;1.8/70	0.39;0.33/230	0.1;0.082/440
Winding code	50Hz/60Hz	B1/G1	B4/G4	C1/H1	D1/J1	D5/J5

Circuit diagram Parallel circuit

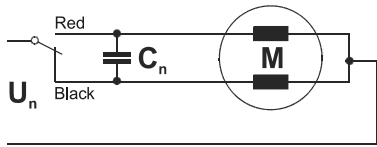

Red = clockwise rotation  
Black = counter clockwise rotation

Dimensions

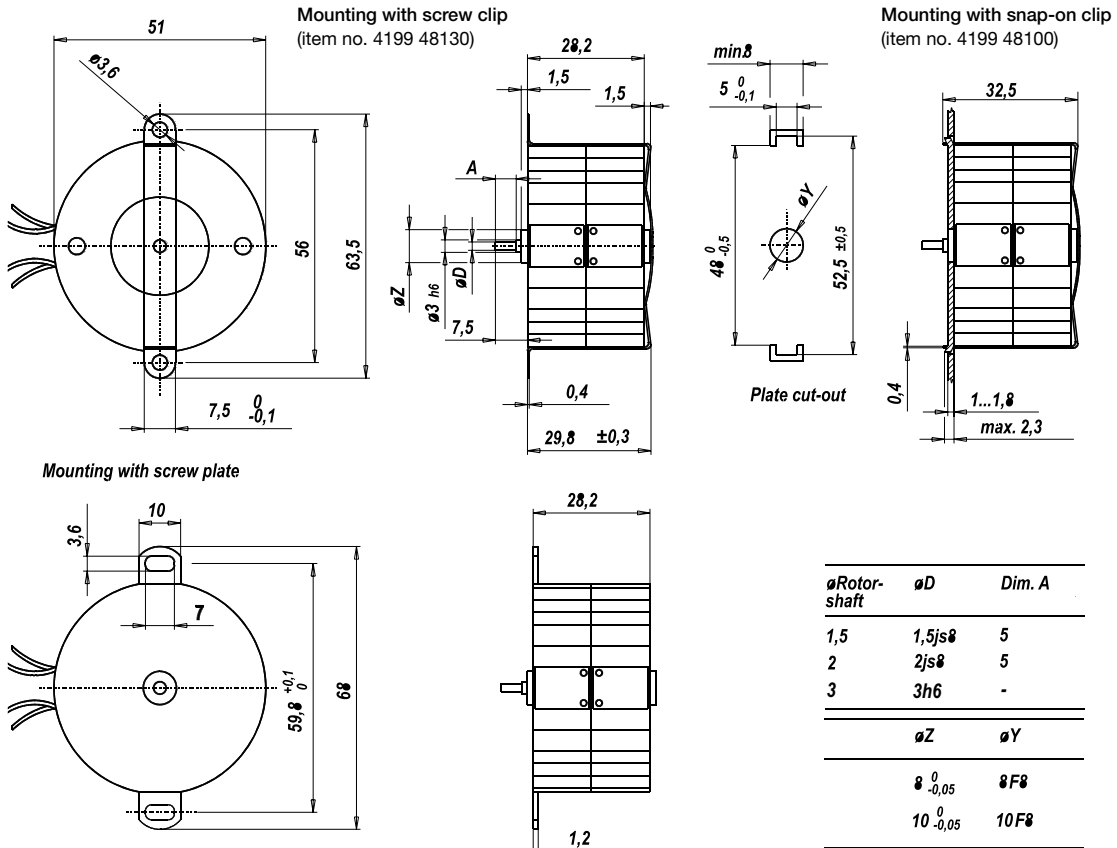

## UFU1

Dimensions (mm)	∅ 52 x 28
Voltage (V)	24–230
Speed (rpm) 50 Hz	375
60 Hz	450
Pole number	16
Running torque (cNm)	
50 Hz	3.0
60 Hz	2.8
Power output (W)	
50 Hz	1.2
60 Hz	1.3
Gear combination	D, M, B, F, V, J (i ≤ 2k), O, P

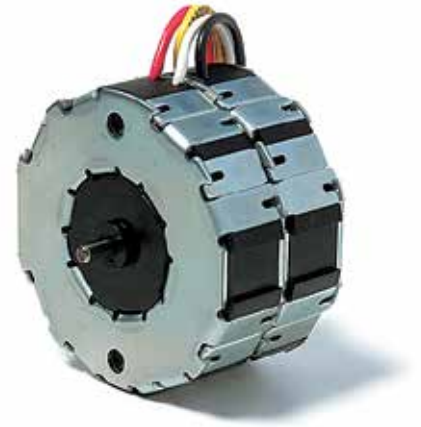

Note: Running torque = Pull-out torque (starting motor at no load, then torque increase)  
Running torque and Power output are minimum values, at rated voltage and motor temperature 23°C

## Standard Data

Climatic class	wide-spread according to DIN IEC 60721-2-1 : 2015
Ambient temperature operation	°C -15...+55
Ambient temperature storage	°C -20...+100
Thermal resistance at f=0 R <sub>therm</sub>	13 K/W
Thermal class	105 (A) according to DIN EN 60085 : 2008 (130 / B on request)
Approval	standard
Mounting	any position
Electrical connection	cable
Protection	IP40 according to DIN EN 60529 : 2014
Weight	180 g
Rotor stalling	motor can be stopped when voltage is applied, without being overheated
Bearings	sintered bronze, self-lubricating
Electric strength	according to DIN EN 60034-1/DIN EN 60335-1

## Order Reference

Type	Synchronous Motor	UFU1	00	N	B4	R	N
Rotor shaft, mounting	0 centring 8 mm, shaft 3.0 mm, clip	E centring 10 mm, shaft 3.0 mm, screw plate					
	1 centring 8 mm, shaft 2.0 mm, clip	K centring 10 mm, shaft 2.0 mm, screw plate					
	2 centring 8 mm, shaft 1.5 mm, clip	M centring 10 mm, shaft 1.5 mm, screw plate					
	3 centring 8 mm, shaft 3.0 mm, screw plate	B centring 10 mm, shaft 3.0 mm, clip					
	4 centring 8 mm, shaft 2.0 mm, screw plate	A centring 10 mm, shaft 2.0 mm, clip					
	5 centring 8 mm, shaft 1.5 mm, screw plate	C centring 10 mm, shaft 1.5 mm, clip					
		D centring 12 mm, shaft 3.0 mm, clip					
Approval	N Approval Standard						
Voltage/Frequency	See next page						
Direction	reversible						
Cable	N cable 150 mm (other on request)						

All specifications are representative only and maybe subject to variation. For confirmation of values, please contact Johnson Electric.  
Please also read "Saia Motors Important Notes" on catalog or at [www.johnsonelectric.com/SaiaMotorsNotes](http://www.johnsonelectric.com/SaiaMotorsNotes)

## Technical Data

Rated frequency	Hz	50	60	
Speed n	rpm	375	450	
Power consumption	W	3.2	3.5	
Power output	W	1.2	1.3	
Running torque	cNm	3.0	2.8	
Rotor inertia $J_R$	gcm <sup>2</sup>	14.4		
Detent torque $M_s$	cNm	0.38		
Tolerance of voltage		standard power supply system + 10% / - 10%		
Winding temperature $T_{max}$	°C	105		
Direction of rotation		reversible		
Rated voltage $U_N$	V	24	110	230
Duty cycle	%	100	100	100
Resistance $R_{20}$	$\Omega$	95	2200	8400
Capacitor $C_n$ (50Hz, 60Hz)	$\mu F/V \pm 10\%$	10;8.2/48	0.47;0.39/220	0.1;0.082/460
Winding code	50Hz/60Hz	B4/G4	C8/H8	D5/J5

Circuit diagram Parallel circuit

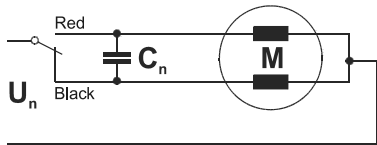

Red = clockwise rotation  
Black = counter clockwise rotation

Dimensions

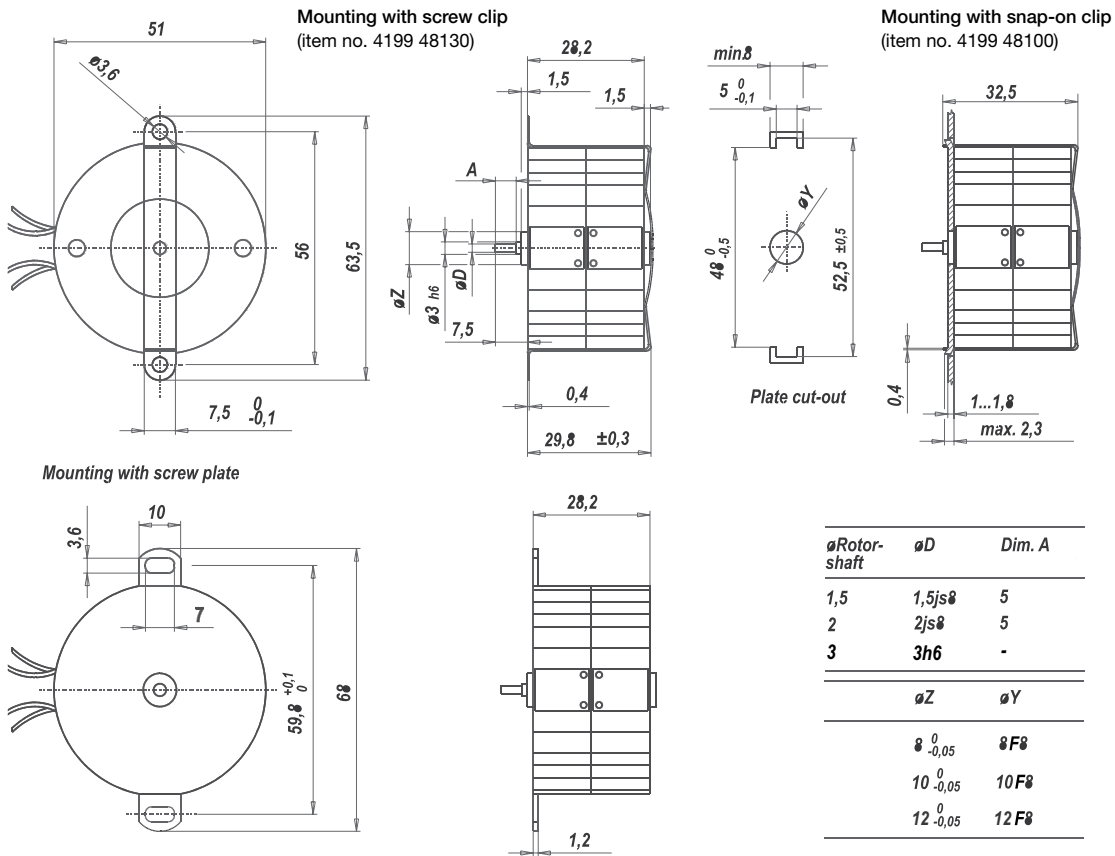

Lead wires: AWG 22 (0.34 mm<sup>2</sup>), insulation diameter  $\varnothing 1.72 \pm 0.08$  mm, 6 mm stripped

## UFR1/UFR3/UFR4

Dimensions (mm) Ø 52 x 28 / Ø 52 x 42 / Ø 52 x 56

Voltage (V) 12–230

Speed (rpm) 50 Hz 500  
60 Hz 600

Pole number 12

Running torque (cNm)  
50 Hz 2.4 / 3.1 / 4.5  
60 Hz 2.2 / 2.6 / 4.0

Power output (W)  
50 Hz 1.3 / 1.6 / 2.4  
60 Hz 1.4 / 1.6 / 2.5

Gear combination D, M, B, F, V, J ( $i \leq 2k$ ), O, P

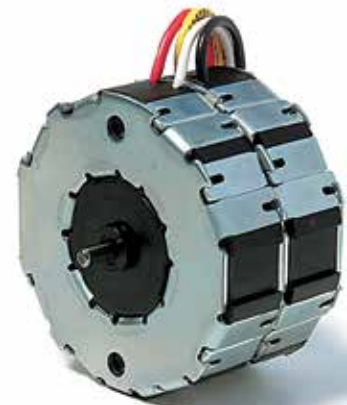

UFR1

Note: Running torque = Pull-out torque (starting motor at no load, then torque increase)  
Running torque and Power output are minimum values, at rated voltage and motor temperature 23°C

## Standard Data

Climatic class	wide-spread according to DIN IEC 60721-2-1 : 2015
Ambient temperature operation	°C -15...+55
Ambient temperature storage	°C -20...+100
Thermal resistance at f=0 $R_{therm}$	11 K/W (UFR1), 7 K/W (UFR4)
Thermal class	105 (A) according to DIN EN 60085 : 2008 (130 / B on request)
Approval	standard (UL/CSA on request)
Mounting	any position
Electrical connection	lead wires AWG22, insulation Ø 1.72 ± 0.08 mm
Protection	IP40 according to DIN EN 60529 : 2014
Weight	180 g (UFR1), 370 g (UFR4)
Rotor stalling	motor can be stopped when voltage is applied, without being overheated
Bearings	sintered bronze, self-lubricating
Electric strength	according to DIN EN 60034-1/DIN EN 60335-1

## Order Reference

Type	Synchronous Motor		UFR	1	0	N	B4	R	N
Configuration	1	Two coils							
	3	Three coils							
	4	Four coils							
Rotor shaft, mounting	0	centring 8 mm, shaft 3.0 mm, clip	B	centring 10 mm, shaft 3.0 mm, clip					
	1	centring 8 mm, shaft 2.0 mm, clip	A	centring 10 mm, shaft 2.0 mm, clip					
	2	centring 8 mm, shaft 1.5 mm, clip	C	centring 10 mm, shaft 1.5 mm, clip					
	3	centring 8 mm, shaft 3.0 mm, screw plate*	D	centring 12 mm, shaft 3.0 mm, clip					
	4	centring 8 mm, shaft 2.0 mm, screw plate*	E	centring 10 mm, shaft 3.0 mm, screw plate*					
	5	centring 8 mm, shaft 1.5 mm, screw plate*	K	centring 10 mm, shaft 2.0 mm, screw plate*					
			M	centring 10 mm, shaft 1.5 mm, screw plate*					
Approval	N	Approval Standard							
Voltage/Frequency	See next page								
Direction	reversible								
Cable	N	cable 150 mm (other on request)							

\* screw plate not for UFR3 and UFR4

All specifications are representative only and maybe subject to variation. For confirmation of values, please contact Johnson Electric.  
Please also read "Saia Motors Important Notes" on catalog or at [www.johnsonelectric.com/SaiaMotorsNotes](http://www.johnsonelectric.com/SaiaMotorsNotes)

## Technical Data

UFR1	Rated frequency	Hz	50	60			
	Speed n	rpm	500	600			
	Power output P <sub>mech</sub>	W	1.3	1.4			
	Running torque M <sub>n</sub>	cNm	2.4	2.2			
	Power consumption P <sub>el</sub>	W	3.3	3.6			
	Detent torque M <sub>s</sub>	cNm	0.39				
	Rotor inertia J <sub>R</sub>	gcm <sup>2</sup>	14.2				
	Rated voltage U <sub>N</sub>	V	12	24	48	110	230
	Duty cycle	%	100	100	100	100	100
	Resistance R <sub>20</sub>	Ω	27	105	400	2400	9100
	Capacitor C <sub>n</sub> (50Hz, 60Hz)	μF/V ±10%	39;33/24	10;8.2/45	2.7;2.2/90	0.47;0.39/230	0.12;0.10/440
	Winding code	50Hz/60Hz	B1/G1	B4/G4	C1/H1	C8/H8	D5/J5
	UFR3	Rated frequency	Hz	50	60		
Speed n		rpm	500	600			
Power output P <sub>mech</sub>		W	1.6	1.6			
Running torque M <sub>n</sub>		cNm	3.1	2.6			
Power consumption P <sub>el</sub>		W	6.1	5.1			
Detent torque M <sub>s</sub>		cNm	0.46				
Rotor inertia J <sub>R</sub>		gcm <sup>2</sup>	17				
Rated voltage U <sub>N</sub>		V	12	24	48	110	230
Duty cycle		%	100	100	100	100	100
Resistance R <sub>20</sub>		Ω	19	70	280	1520	5850
Capacitor C <sub>n</sub> (50Hz, 60Hz)		μF/V ±10%	150;100/12	39;27/24	10;6.8/48	1.8;1.2/110	0.47;0.33/230
Winding code		50Hz/60Hz	B1/G1	B4/G4	C1/H1	C8/H8	D5/J5
UFR4		Rated frequency	Hz	50	60		
	Speed n	rpm	500	600			
	Power output P <sub>mech</sub>	W	2.4	2.5			
	Running torque M <sub>n</sub>	cNm	4.5	4.0			
	Power consumption P <sub>el</sub>	W	6.4	6.9			
	Detent torque M <sub>s</sub>	cNm	0.68				
	Rotor inertia J <sub>R</sub>	gcm <sup>2</sup>	24.2				
	Rated voltage U <sub>N</sub>	V	24	48	110	230	
	Duty cycle	%	100	100	100	100	
	Resistance R <sub>20</sub>	Ω	56	210	1200	4800	
	Capacitor C <sub>n</sub> (50Hz, 60Hz)	μF/V ±10%	18;15/45	4.7;3.9/90	0.82;0.68/200	0.22;0.18/400	
	Winding code	50Hz/60Hz	B4/G4	C1/H1	C8/H8	D5/J5	
	Tolerance of voltage		standard power supply system + 10% ... - 10%				
Winding temperature T <sub>max</sub>	°C	105					
Direction of rotation		reversible					

Circuit diagram UFR1 Parallel circuit

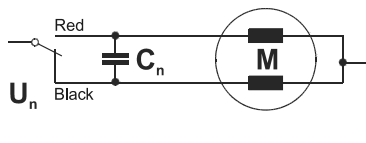

UFR4 Parallel circuit

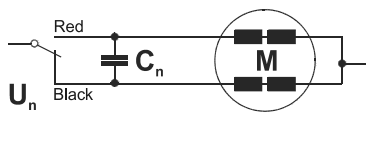

UFR3 Parallel circuit

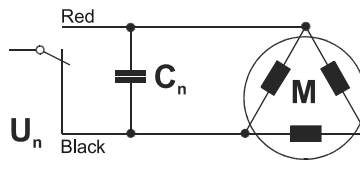

Red = clockwise rotation  
Black = counter clockwise rotation

Dimensions

UFR1

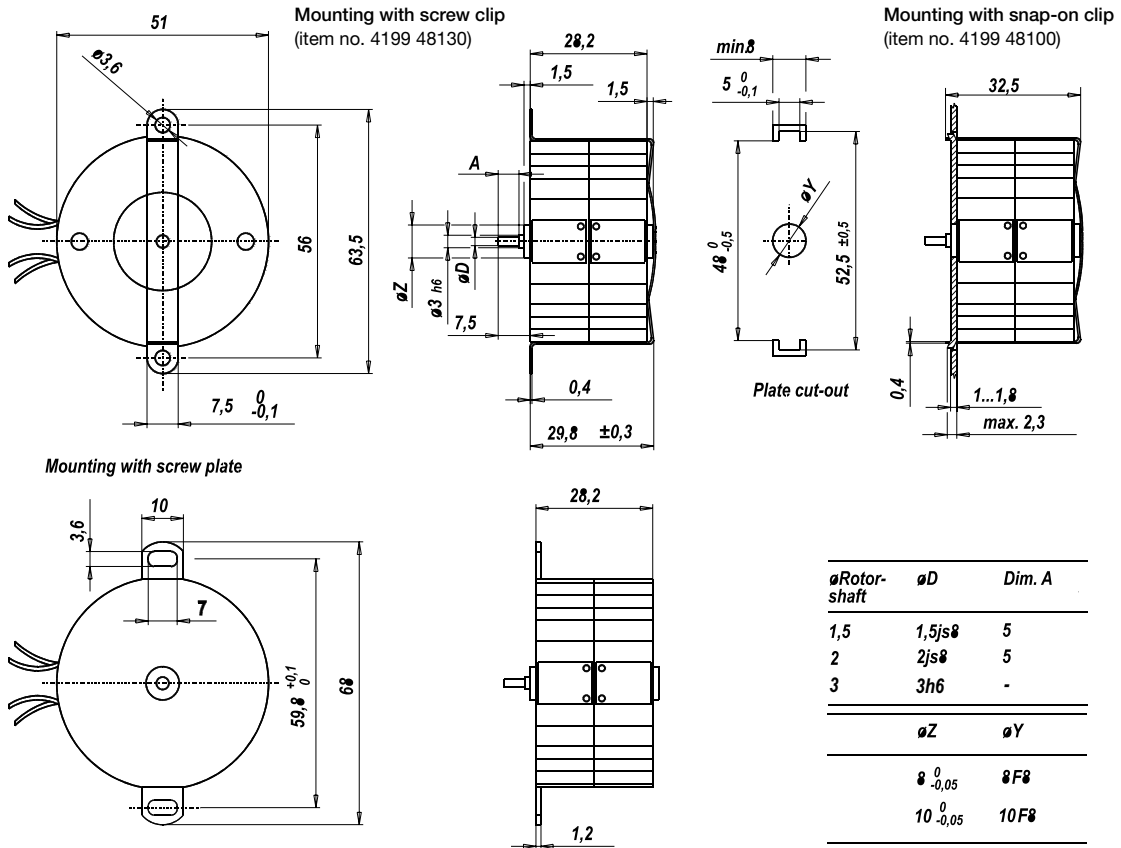

UFR3

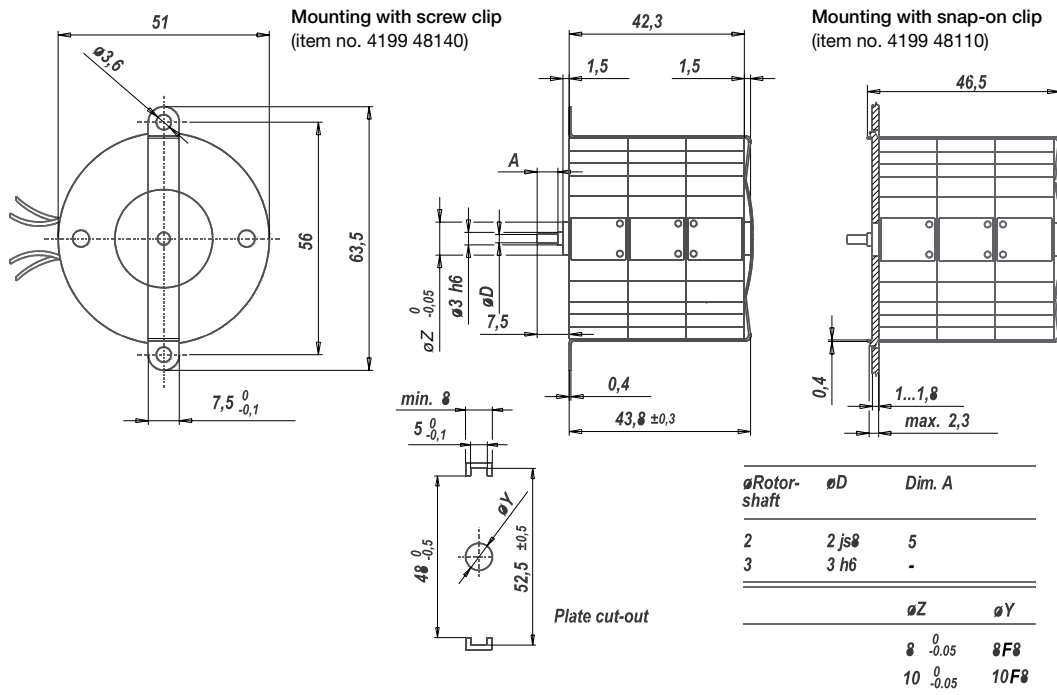



Dimensions  
UFR4

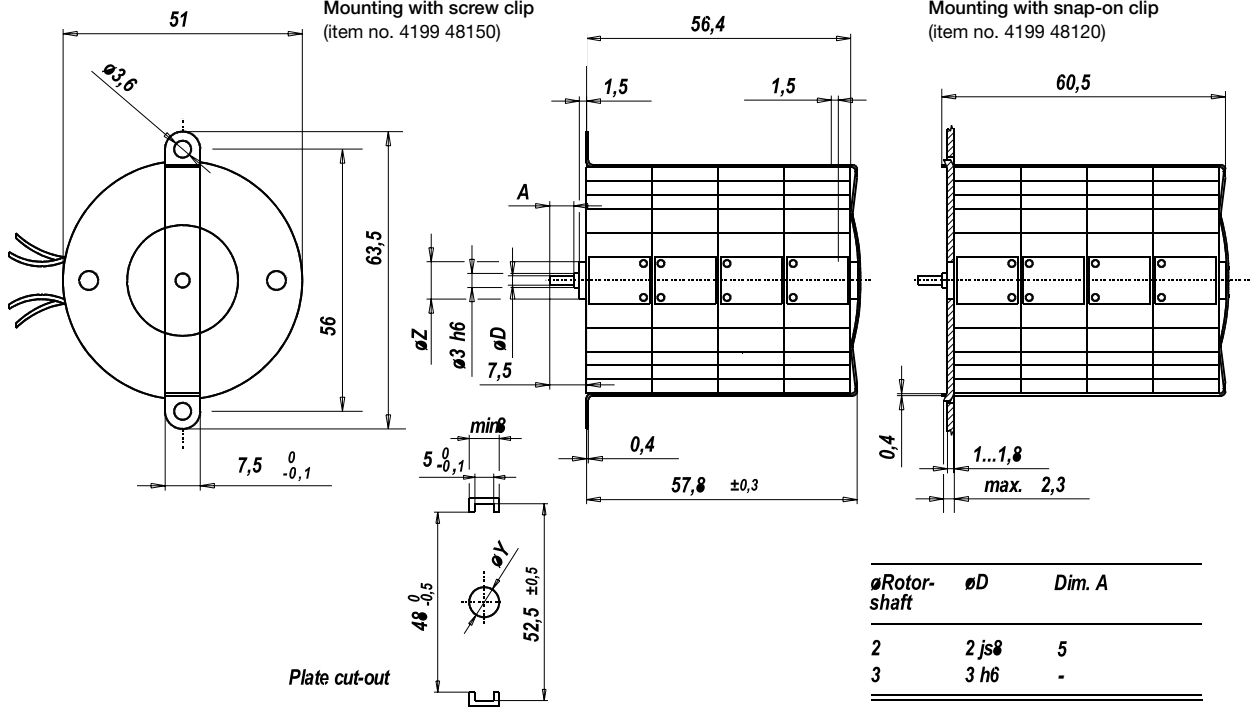

$\phi$ Rotor-shaft	$\phi D$	Dim. A
2	2 js8	5
3	3 h6	-

$\phi Z$	$\phi Y$
8 $^{0}_{-0,05}$	8F8
10 $^{0}_{-0,05}$	10F8

## UP (SM6443; SM6444)

Dimensions (mm)	∅ 64 x 43
Voltage (V)	12–230
Speed (rpm) 50 Hz	375
60 Hz	450
Pole number	16
Running torque (cNm) 50 Hz	11.1–15.2 (UPU1); 26.0–30.4 (UPU5)
60 Hz	9.0–14.5 (UPU1); 21–25.5 (UPU5)
Power output (W) 50 Hz	4.4–6.0 (UPU1); 10.2–11.9 (UPU5)
60 Hz	4.2–6.8 (UPU1); 9.9–12.0 (UPU5)
Gear combination	O, P, R



Note: Running torque = Pull-out torque (starting motor at no load, then torque increase)  
Running torque and Power output are minimum values, at rated voltage and motor temperature 23°C

### Standard Data

Climatic class	wide-spread according to DIN IEC 60721-2-1 : 2015
Ambient temperature operation	°C -15 ... +40
Ambient temperature storage	°C -20 ... +100
Thermal class	130 (B) according to DIN EN 60085 : 2008
Approval	standard
Mounting	any position
Electrical connection	lead wires AWG22, insulation ∅ 1.6 ± 0.1 mm
Protection	IP30 according to DIN EN 60529 : 2014
Weight	500 g (UPU1); 550 g (UPU5)
Rotor stalling	motor can be stopped when voltage is applied, without being overheated
Bearings	Sintered bronze, self-lubricating

### Order Reference

Type	Synchronous Motor	UPU	1	1	N	B4	R	E
Configuration	1 standard magnet 5 stronger magnet							
Rotor shaft, mounting	1 centring 10 mm, shaft length 8,1 mm, screw plate 2 centring 10 mm, shaft length 15,5 mm, screw plate A centring 14 mm, shaft length 8,1 mm, screw plate C centring 14 mm, shaft length 15,5 mm, screw plate							
Approval	N standard							
Voltage/Frequency	see next page							
Direction	R reversible							
Cable	E 150 mm (other upon request)							

All specifications are representative only and maybe subject to variation. For confirmation of values, please contact Johnson Electric.  
Please also read "Saia Motors Important Notes" on catalog or at [www.johnsonelectric.com/SaiaMotorsNotes](http://www.johnsonelectric.com/SaiaMotorsNotes)

## Technical Data

UPU1		Standard			S2 version (Z20)	
Rated frequency	Hz	50	60	50	60	
Speed	rpm	375	450	375	450	
Running torque Mn	cNm	11.1	9.0	15.2	14.5	
Power output	W	4.4	4.2	6.0	6.8	
Power consumption	VA	10.5	13.4	16.8	19.4	
Detent torque MS	cNm	1.7	1.7	1.7	1.7	
Winding temperature increase	K	95	100	90 (S2 20 min)		
Weight	g	500	500	500	500	
Standard windings						
Rated voltage $U_N$	V	24	115	230		
Duty cycle	%	100	100	100		
Resistance $R_{20}$	$\Omega$	26	560	2450		
Capacitor C(50/60 Hz)	$\mu F \pm 10\%/V$	30/63	1,3/250	0,33/500		
Winding code		B4/G4	D0/J0	D5/J5		
UPU5		Special version (Z21)			Standard	
Rated frequency	Hz	50	60	50	60	
Speed	rpm	375	450	375	450	
Running torque Mn	cNm	26.0	21.0	30.4	25.5	
Power output	W	10,2	9,9	11.9	12.0	
Power consumption	VA	26	28	26.3	33,5	
Detent torque MS	cNm	6	6	6	6	
Winding temperature increase	K	85 (S2 6,5 min)	85 (S2 6,5 min)	95 (S2 5 min)	95 (S2 5 min)	
Weight	g	550	550	550	550	
Standard windings						
Rated voltage $U_N$	V	24	48	115	230	
Duty cycle	%					
Resistance $R_{20}$	$\Omega$	9,5	37	230	810	
Capacitor C(50/60 Hz)	$\mu F \pm 10\%/V$	82/63	20/160	3,3/250	0,82/500	
Winding code		B4/G4	C1/H1	D0/J0	D5/J5	

Circuit diagram Clockwise rotation

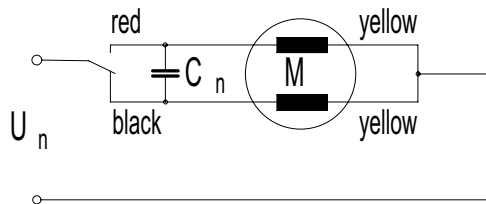

Dimensions mounting dimensions UP with screw plate

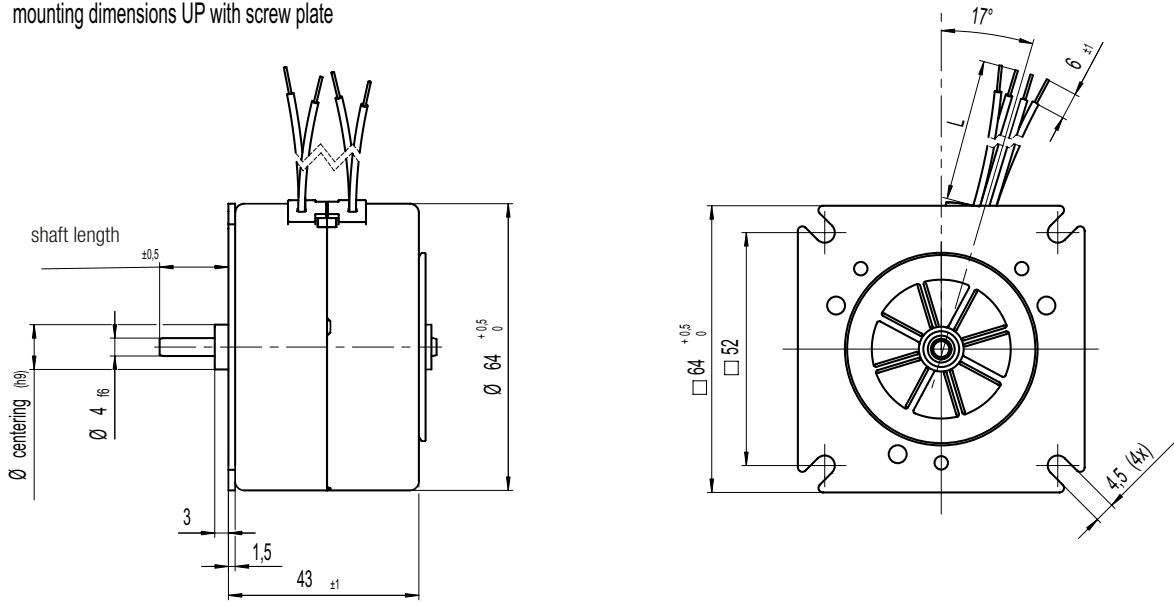

## Chart: Torque versus Voltage

UPU1

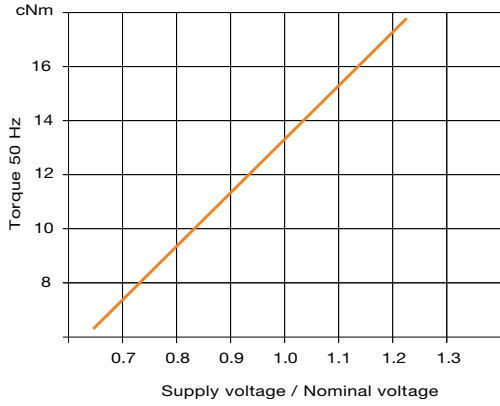

UPU1 S2 version (Z20)

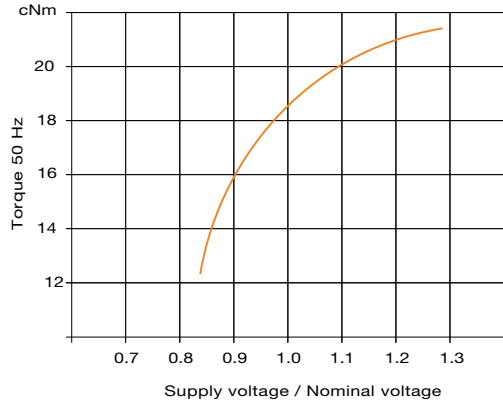

## Chart: Possible S2 ON time versus load torque

UPU5 special version (Z21)

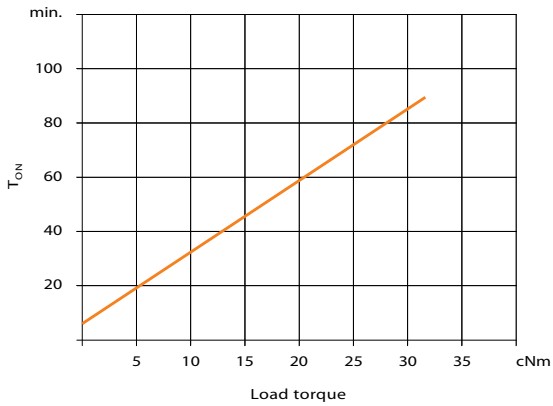

UPU5 standard

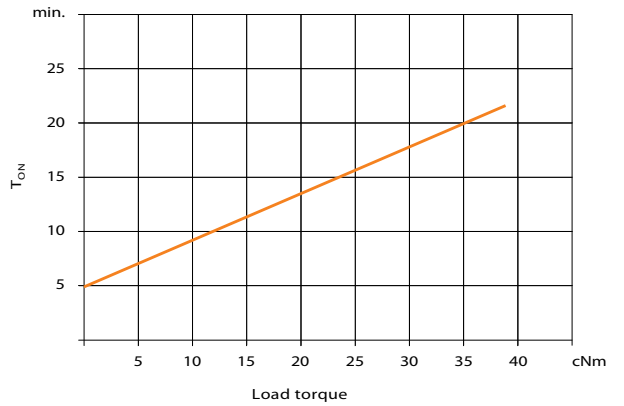

## Chart: Torque versus Voltage

UPU5 special version (Z21)

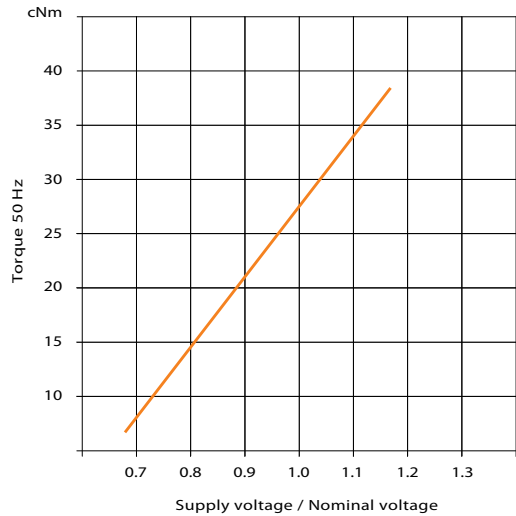

UPU5 standard

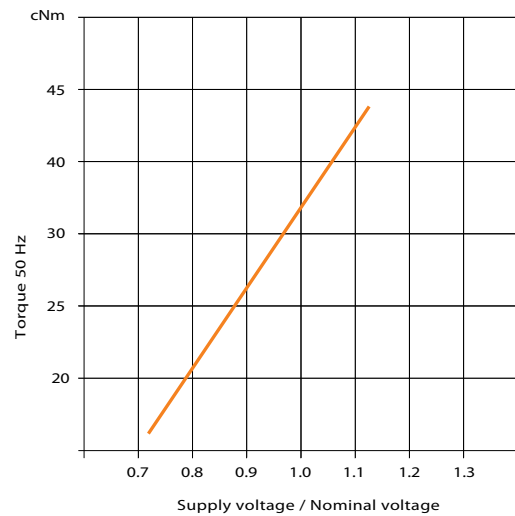

# Stepper Motors Rotational

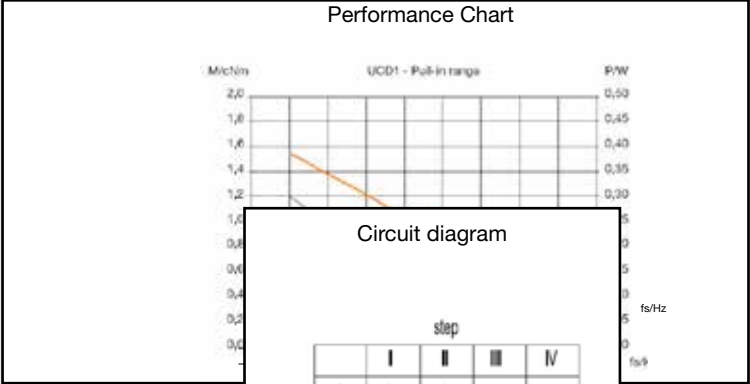
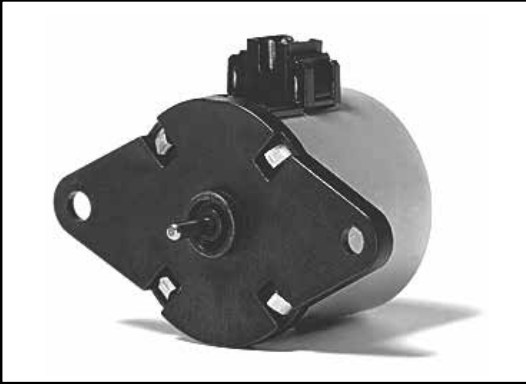

Circuit diagram

		step			
		I	II	III	IV
connector	1	+	+	-	-
	3	-	-	+	+
	4	-	+	+	-
	6	+	-	-	+

→ counter clockwise rotation  
 ← clockwise rotation

# UAG3/4

## 3/4

Dimensions (mm)	∅ 20 x 17
Step angle (°)	18
Holding torque (mNm)	5.3 / 3.9 (standard magnet, stronger magnet on request)
Detent torque (mNm)	> 0.6 (standard magnet, stronger magnet on request)
Winding	bipolar/unipolar
Gear combination	on request



Note: All torque and power output values are minimum values, at rated voltage and motor temperature 23°C.

### Standard Data

Climatic class	wide-spread according to DIN IEC 60721-2-1 : 2015
Ambient temperature operation	°C -20...+60
Ambient temperature storage	°C -40...+100
Thermal resistance at f=0 R <sub>therm</sub>	47 K/W
Thermal class	130 (B) according to DIN EN 60085 : 2008
Approval	standard
Mounting	any position
Electrical connection	lead wires AWG28, insulation ∅ 0.82 mm
Protection	IP40 according to DIN EN 60529 : 2014
Weight	22 g
Rotor stalling	motor can be stopped when voltage is applied, without being overheated
Bearings	sintered bronze, self-lubricating

### Order Reference

Type	Stepper Motor	UAG	3	3	N	05	R	E
Configuration	3 bipolar 4 unipolar							
Rotor shaft, mounting	3 centring 8 mm, mounting plate with long holes 5 centring 8 mm, mounting plate (for clipping) E centring 6 mm, mounting plate with long holes G centring 6 mm, mounting plate (for clipping)							
Approval	N Approval Standard							
Resistance	See next page Resistance per winding for bipolar or unipolar.							
Direction	reversible							
Cable	E cable 150 mm with Tyco connector CT 173977-4 1-6 (other on request)							

All specifications are representative only and maybe subject to variation. For confirmation of values, please contact Johnson Electric. Please also read "Saia Motors Important Notes" on catalog or at [www.johnsonelectric.com/SaiaMotorsNotes](http://www.johnsonelectric.com/SaiaMotorsNotes)

## Technical Data

bipolar (UAG3)	Rated voltage UN	V	12	6
	Duty cycle	%	100	100
	Resistance R <sub>20</sub>	Ω	150	40
	Winding code		05	07
unipolar (UAG4)	Rated voltage UN	V	12	
	Duty cycle	%	100	
	Resistance R <sub>20</sub>	Ω	150	
	Winding code		06	
Steps per revolution		20		
Winding temperature T <sub>max</sub>		130° C		
Rotor inertia J <sub>R</sub>		0.26 gcm <sup>2</sup>		
Holding torque M <sub>H</sub>		0.53 cNm (UAG3) 0.39 cNm (UAG4) (standard magnet, stronger magnet on request)		
Detent torque M <sub>H</sub>		> 0.6 mNm		
Direction of rotation		reversible		

### Dimensions

motor type	∅ D	
UAG30	∅ 8	0 -0.05
UAG3A	∅ 6	0 -0.05
UAG40	∅ 8	0 -0.05
UAG4A	∅ 6	0 -0.05

motor type	∅ D	
UAG33	∅ 8	0 -0.05
UAG3E	∅ 6	0 -0.05
UAG43	∅ 8	0 -0.05
UAG4E	∅ 6	0 -0.05

motor type	∅ D	
UAG35	∅ 8	0 -0.05
UAG3G	∅ 6	0 -0.05
UAG45	∅ 8	0 -0.05
UAG4G	∅ 6	0 -0.05

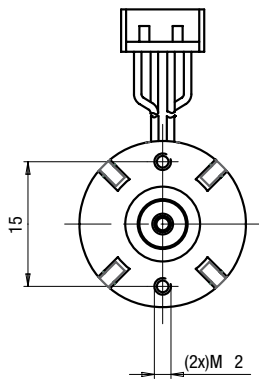

Use bolts with thread length 4mm max. Screw in torque 10cNm max.

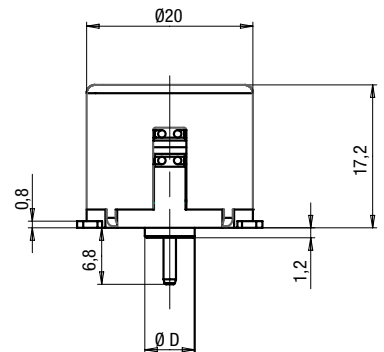
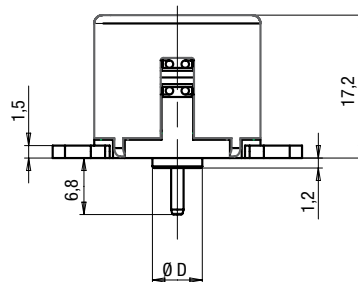
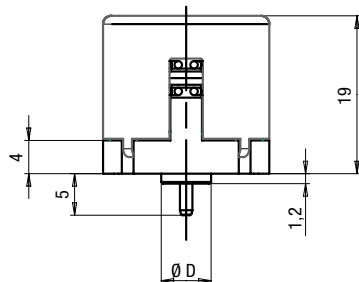
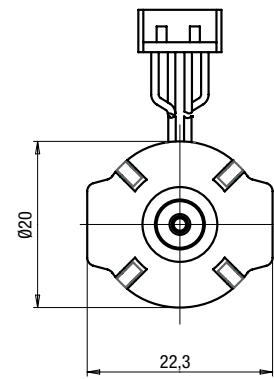
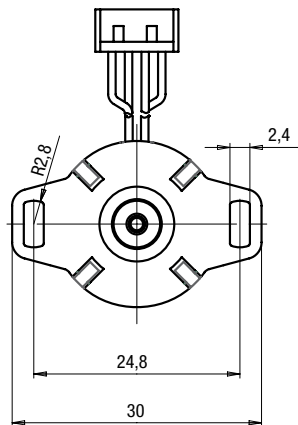



# UAG3/4

## Dimensions

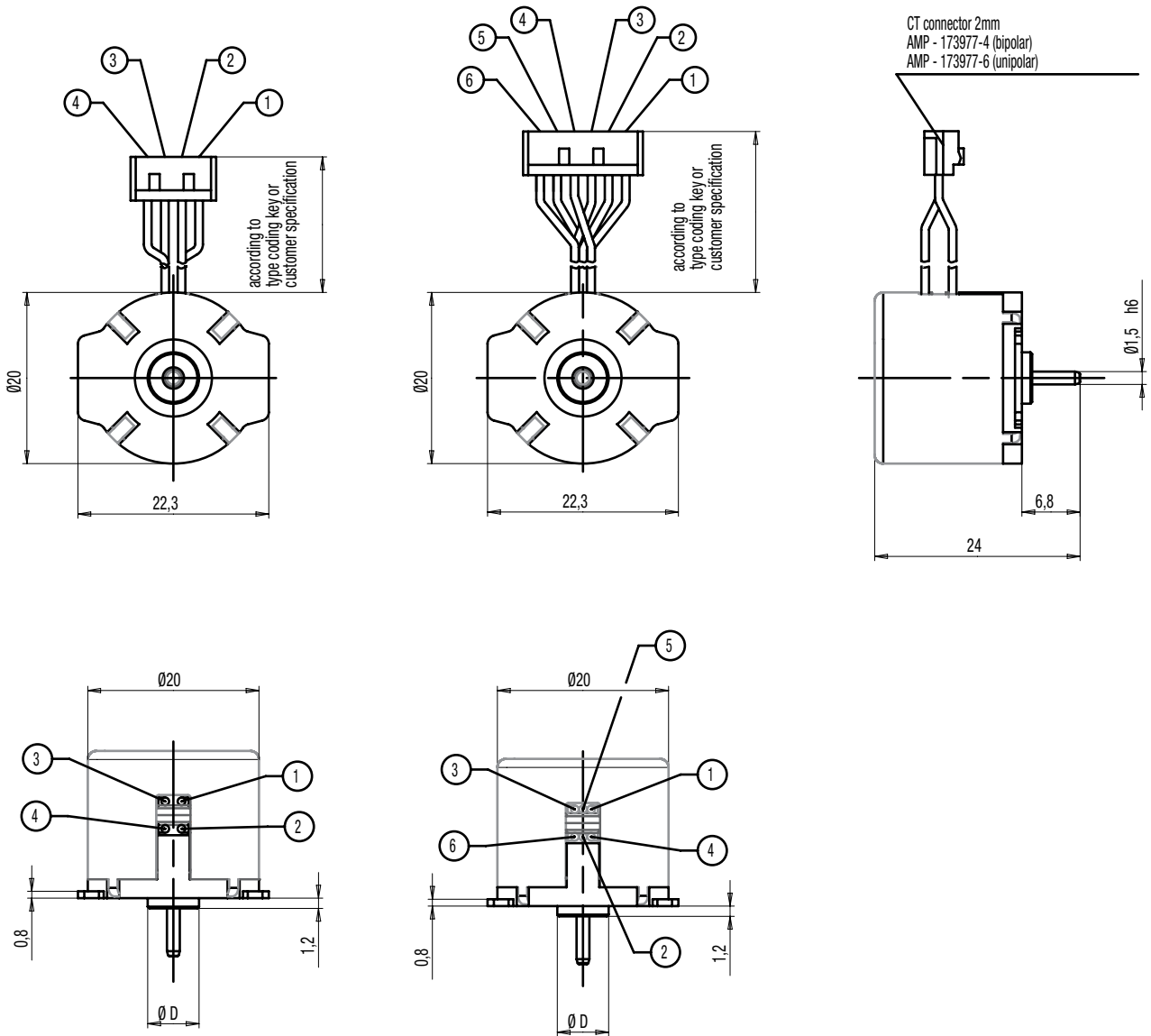

## Circuit diagram

bipolar

		step				
		0	I	II	III	IV
wire	1	+	+	-	-	+
	2	+	-	-	+	+
	3	-	-	+	+	-
	4	-	+	+	-	-

unipolar

		step				
		0	I	II	III	IV
wire	1	-	-			-
	2	-			-	-
	3	+	+	+	+	+
	4	+	+	+	+	+
	5			-	-	
	6		-	-		

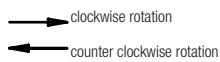

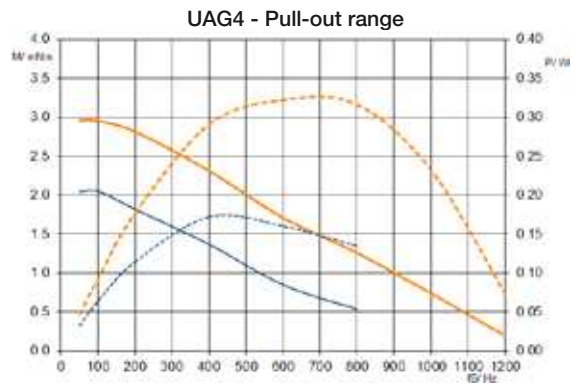
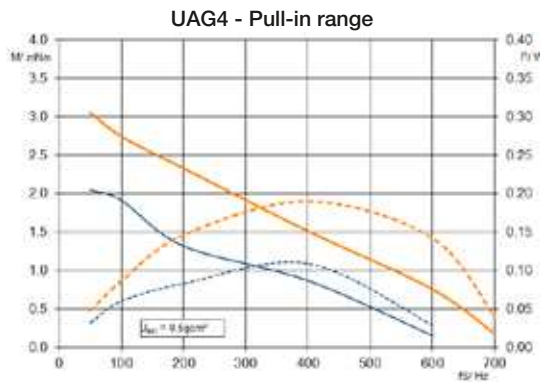
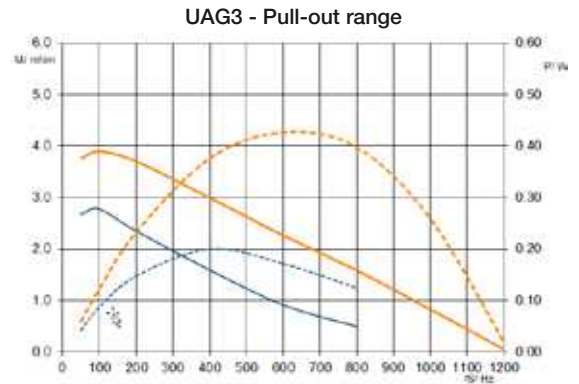
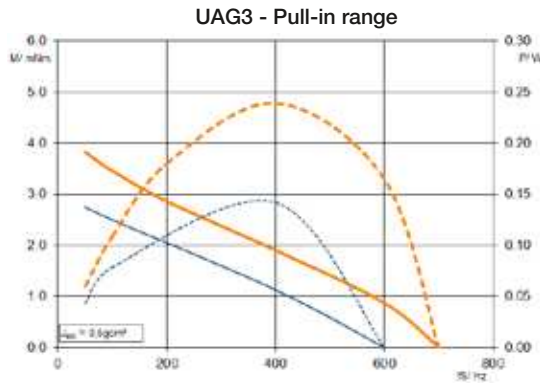

UAG3 - Pull-out range chopper (winding 40ohm, voltage 24Vdc)

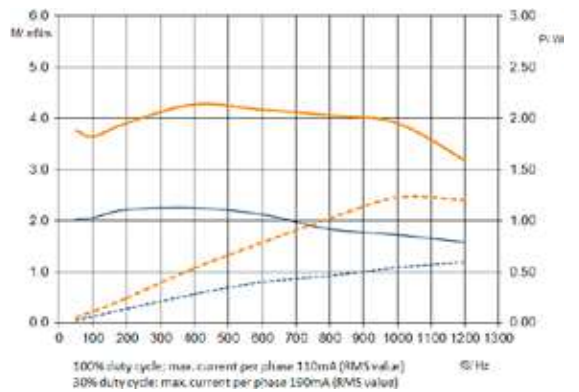

— M - Duty cycle 30 %  
 — M - Duty cycle 100%

--- P - Duty cycle 30 %  
 --- P - Duty cycle 100 %

## UCD1/7; UCD2/8



Dimensions (mm)	∅ 28 x 24
Step angle (°)	7.5
Holding torque* (cNm)	1.4–2.3
Detent torque (cNm)	0.15–0.30
Winding	bipolar/unipolar
Gear combination	on request

\* values for connector version (connection B or D) / values of lead wire version (connection N) are up to 20 % lower  
 Note: All torque and power output values are minimum values, at rated voltage and motor temperature 23°C.

### Standard Data

Climatic class	wide-spread according to DIN IEC 60721-2-1 : 2015
Ambient temperature operation	°C -15 ... +60
Ambient temperature storage	°C -20 ... +100
Thermal resistance at f=0 R <sub>therm</sub>	29 K/W
Thermal class	130 (B) according to DIN EN 60085 : 2008
Approval	standard
Mounting	any position
Electrical connection	connector type D or N
Protection	IP30 according to DIN EN 60529 : 2014
Weight	54 g
Rotor stalling	motor can be stopped when voltage is applied, without being overheated
Bearings	Sintered bronze, self-lubricating

### Order Reference

Type	Stepper Motor		UCD	1	0	N	18	R	B
Configuration	1	bipolar, standard magnet	7	bipolar, stronger magnet					
	2	unipolar, standard magnet	8	unipolar, stronger magnet					
Rotor shaft, mounting	3	centring 8 mm, shaft 2.0 mm, screw plate	E	centring 10 mm, shaft 2.0 mm, screw plate					
	4	centring 8 mm, shaft 1.5 mm, screw plate	K	centring 10 mm, shaft 1.5 mm, screw plate					
	0	centring 8 mm, shaft 2.0 mm, clip	A	centring 10 mm, shaft 2.0 mm, clip					
	1	centring 8 mm, shaft 1.5 mm, clip	C	centring 10 mm, shaft 1.5 mm, clip					
Approval	N	Approval Standard							
Resistance	see next pages; Resistance per winding for bipolar or unipolar								
Direction	R	reversible							
Connection	D	see next pages "Connection Types" and page 145 "Connection Types" for B							
	N								

All specifications are representative only and maybe subject to variation. For confirmation of values, please contact Johnson Electric.  
 Please also read "Saia Motors Important Notes" on catalog or at [www.johnsonelectric.com/SaiaMotorsNotes](http://www.johnsonelectric.com/SaiaMotorsNotes)

## Technical Data

bipolar	Configuration		UCD1	UCD7	
	Holding torque $M_H^*$	cNm	1.6	2.3	
	Detent torque $M_S$	cNm	0.15	0.3	
	Rotor inertia $J_R$	gcm <sup>2</sup>	2.2	2.4	
	Steps per revolution		48		
Direction of rotation	V	reversible			
<b>Specific Technical Data Lead Wire Versions (Connection type N)</b>					
	Rated voltage $U_N$	V	6	12	24
	Duty cycle	%	100	100	100
	Resistance $R_{20}$	$\Omega$	24	90	380
	Winding code		18	03	04
<b>Specific Technical Data Connector Versions</b>					
	Rated voltage $U_N$	V	6	12	24
	Duty cycle	%	100	100	100
	Resistance $R_{20}$	$\Omega$	24	90	380
	Winding code		07	01	02
unipolar	Configuration		UCD2	UCD8	
	Holding torque $M_H^*$	cNm	1.4	2.0	
	Detent torque $M_S$	cNm	0.15	0.3	
	Rotor inertia $J_R$	gcm <sup>2</sup>	2,1	2,4	
	Steps per revolution		48		
Direction of rotation	V	reversible			
<b>Specific Technical Data Lead Wire Versions</b>					
	Rated voltage $U_N$	V	12	24	6
	Duty cycle	%	100	100	100
	Resistance $R_{20}$	$\Omega$	90	380	24
	Winding code		10	11	12
<b>Specific Technical Data Connector Versions</b>					
	Rated voltage $U_N$	V	12	24	
	Duty cycle	%	100	100	
	Resistance $R_{20}$	$\Omega$	90	380	
	Winding code		01	02	

\* values of connector version (connection B or D) / values of lead wire version are up to 20 % lower

Circuit diagram bipolar

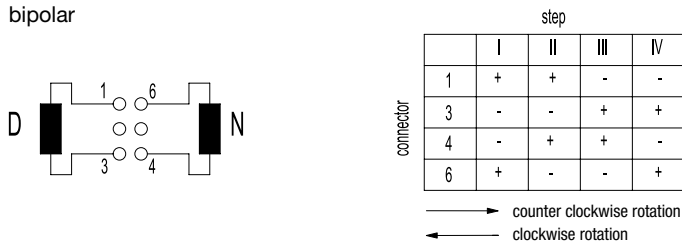

unipolar

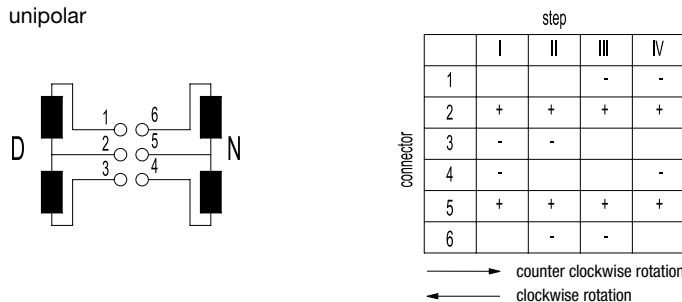

Dimensions Version with Connector D

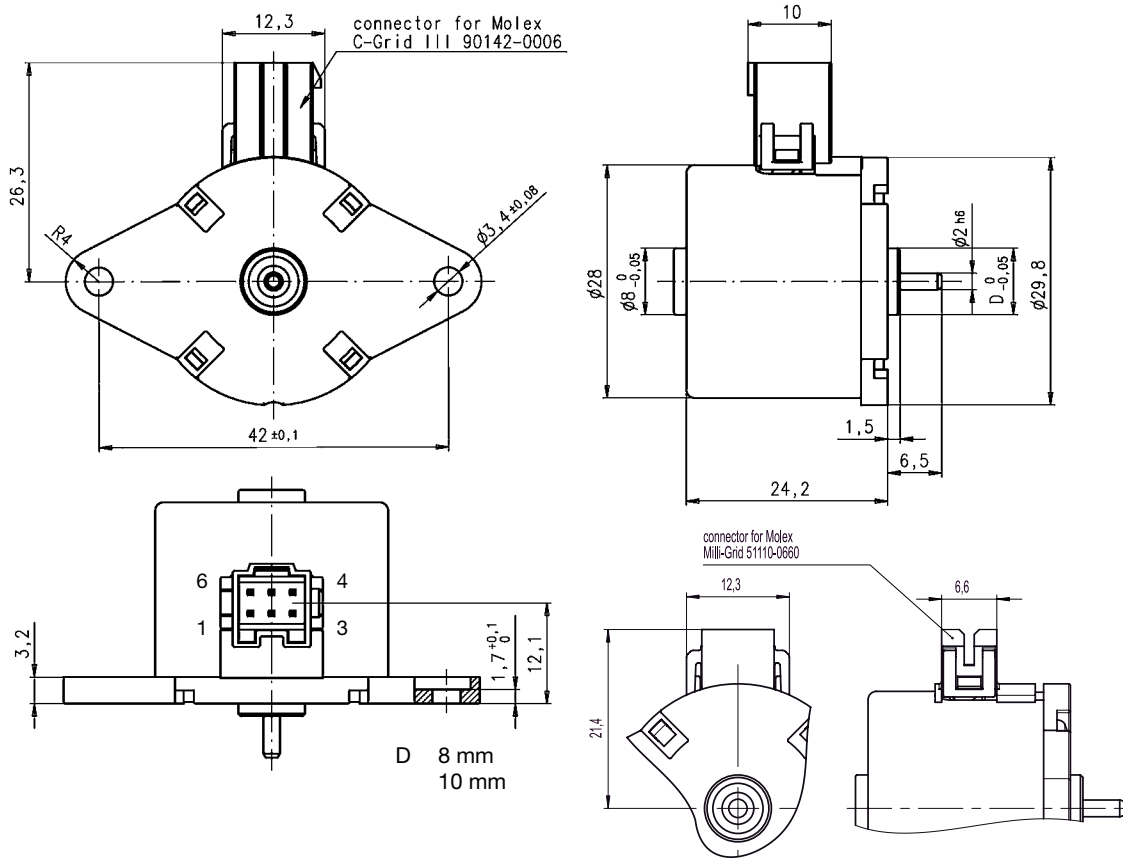

Version with Connector N (Lead wire version)

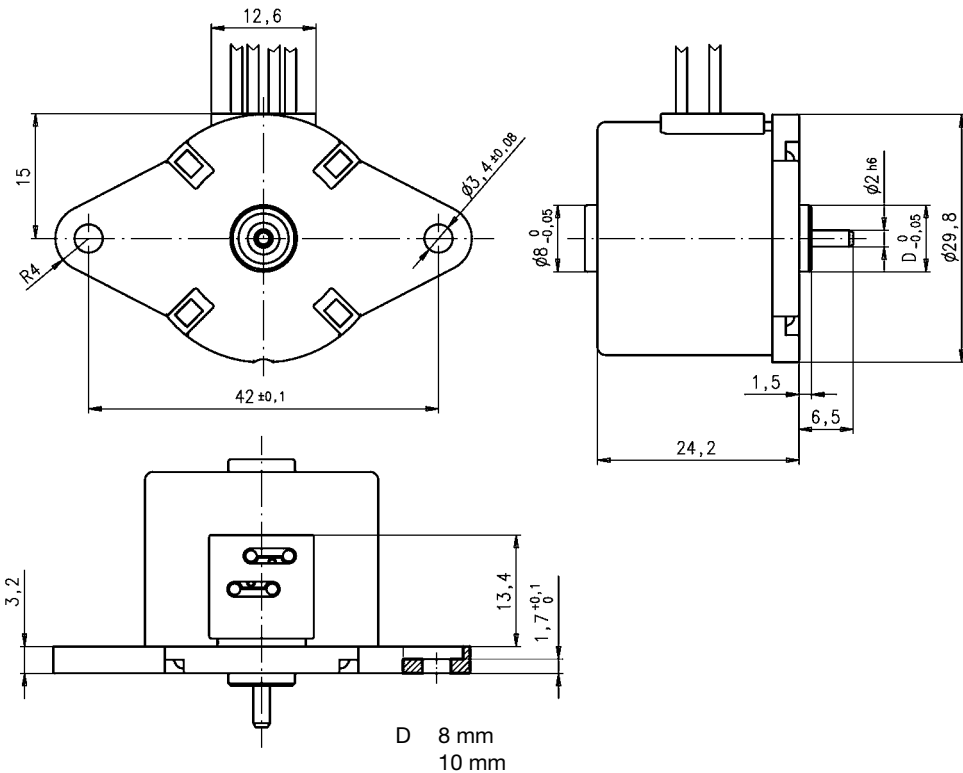

## Performance Chart

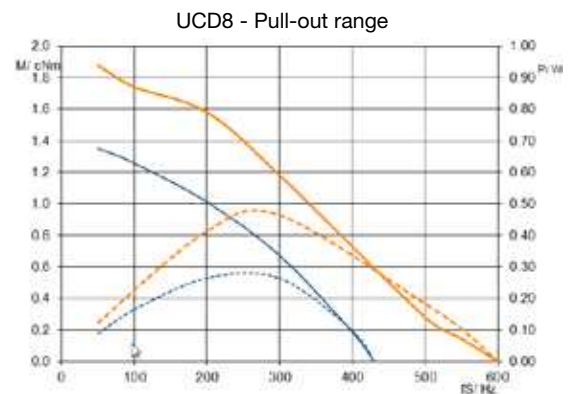
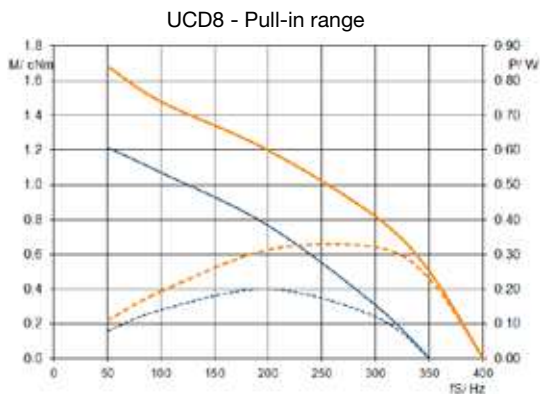
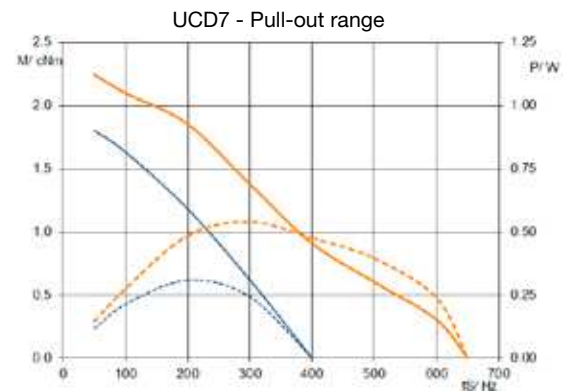
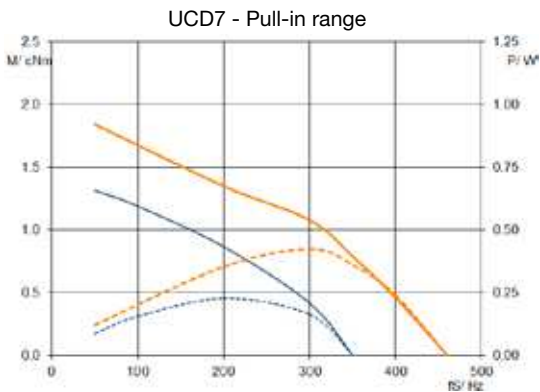
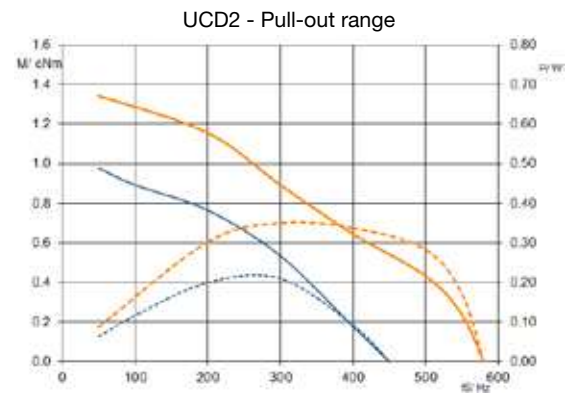
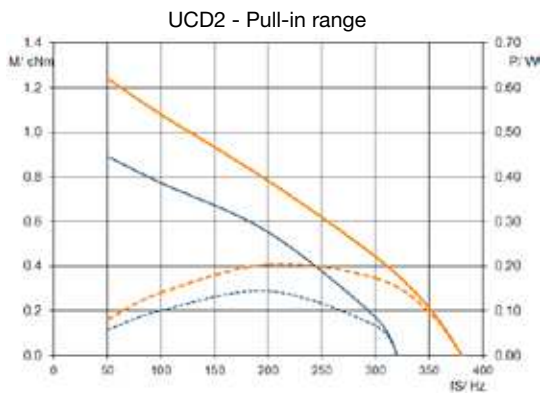
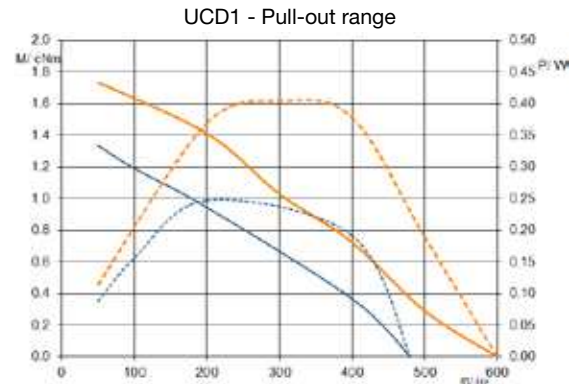
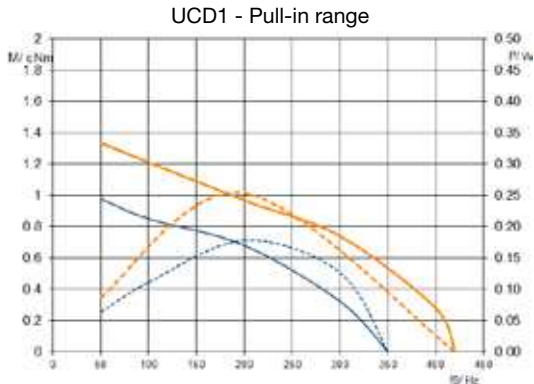

— M - Duty cycle 30 %  
 — M - Duty cycle 100%

- - - P - Duty cycle 30 %  
 - - - P - Duty cycle 100 %

## UCB1/7; UCB2/8

Dimensions (mm) Ø 28 x 24

Step angle (°) 15

Holding torque\*  
(cNm) 1.1–2.4

Detent torque (cNm) 0.17/0.38

Winding bipolar/unipolar

Gear combination on request



\* values for connector version (connection B or D) / values of lead wire version (connection N) are up to 20 % lower.

Note: All torque and power output values are minimum values, at rated voltage and motor temperature 23°C.

### Standard Data

Climatic class	wide-spread according to DIN IEC 60721-2-1 : 2015
Ambient temperature operation	°C -15 ... +60
Ambient temperature storage	°C -20 ... +100
Thermal resistance at f=0 R <sub>therm</sub>	29 K/W
Thermal class	130 (B) according to DIN EN 60085 : 2008
Approval	standard
Mounting	any position
Electrical connection	connector type D or N
Protection	IP30 according to DIN EN 60529 : 2014
Weight	54 g
Rotor stalling	motor can be stopped when voltage is applied, without being overheated
Bearings	Sintered bronze, self-lubricating

### Order Reference

Type	Stepper Motor	UCB	1	0	N	18	R	B
Configuration	1	bipolar, standard magnet	7	bipolar, stronger magnet				
	2	unipolar, standard magnet	8	unipolar, stronger magnet				
Rotor shaft, mounting	3	centring 8 mm, shaft 2.0 mm, screw plate	E	centring 10 mm, shaft 2.0 mm, screw plate				
	4	centring 8 mm, shaft 1.5 mm, screw plate	K	centring 10 mm, shaft 1.5 mm, screw plate				
	0	centring 8 mm, shaft 2.0 mm, clip	A	centring 10 mm, shaft 2.0 mm, clip				
	1	centring 8 mm, shaft 1.5 mm, clip	C	centring 10 mm, shaft 1.5 mm, clip				
Approval	N	Approval Standard						
Resistance		see next pages; Resistance per winding for bipolar or unipolar						
Direction	R	reversible						
Connection	D	see next pages "Connection Types" and page 145 "Connection Types" for B						
	N							

All specifications are representative only and maybe subject to variation. For confirmation of values, please contact Johnson Electric. Please also read "Saia Motors Important Notes" on catalog or at [www.johnsonelectric.com/SaiaMotorsNotes](http://www.johnsonelectric.com/SaiaMotorsNotes)

## Technical Data

bipolar	Configuration		UCB1	UCB7	
	Holding torque $M_H^*$	cNm	1.5	2.4	
	Detent torque $M_S$	cNm	0.17	0.38	
	Rotor inertia $J_R$	gcm <sup>2</sup>	2.1	2.4	
	Steps per revolution		24		
	Direction of rotation	V	reversible		
	<b>Specific Technical Data Lead Wire Versions (Connection type N)</b>				
	Rated voltage $U_N$	V	6	12	24
	Duty cycle	%	100	100	100
	Resistance $R_{20}$	$\Omega$	24	90	380
	Winding code		18	03	04
<b>Specific Technical Data Connector Versions</b>					
	Rated voltage $U_N$	V	6	12	24
	Duty cycle	%	100	100	100
	Resistance $R_{20}$	$\Omega$	24	90	380
	Winding code		07	01	02
unipolar	Configuration		UCB2	UCB8	
	Holding torque $M_H^*$	cNm	1.1	1.8	
	Detent torque $M_S$	cNm	0.17	0.38	
	Rotor inertia $J_R$	gcm <sup>2</sup>	2.1	2.4	
	Steps per revolution		24		
	Direction of rotation	V	reversible		
	<b>Specific Technical Data Lead Wire Versions</b>				
	Rated voltage $U_N$	V	12	24	6
	Duty cycle	%	100	100	100
	Resistance $R_{20}$	$\Omega$	90	380	24
	Winding code		10	11	12
<b>Specific Technical Data Connector Versions</b>					
	Rated voltage $U_N$	V	12	24	
	Duty cycle	%	100	100	
	Resistance $R_{20}$	$\Omega$	90	380	
	Winding code		01	02	

\* values of connector version (connection B or D) / values of lead wire version are up to 20 % lower

Circuit diagram bipolar

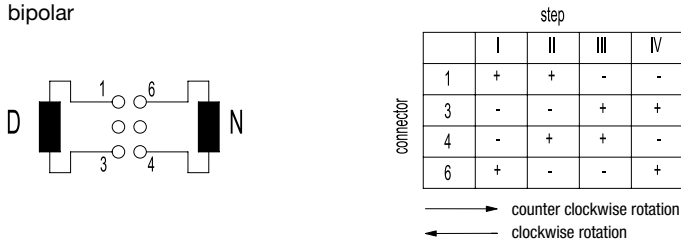

unipolar

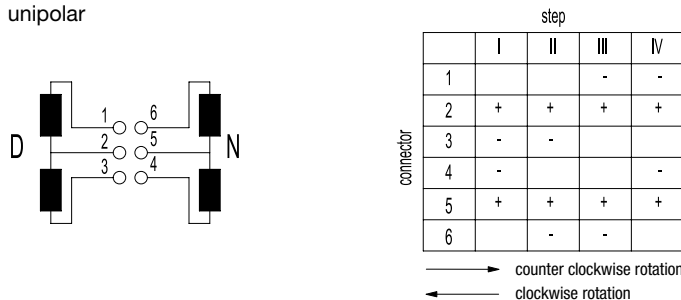



Dimensions Version with Connector D

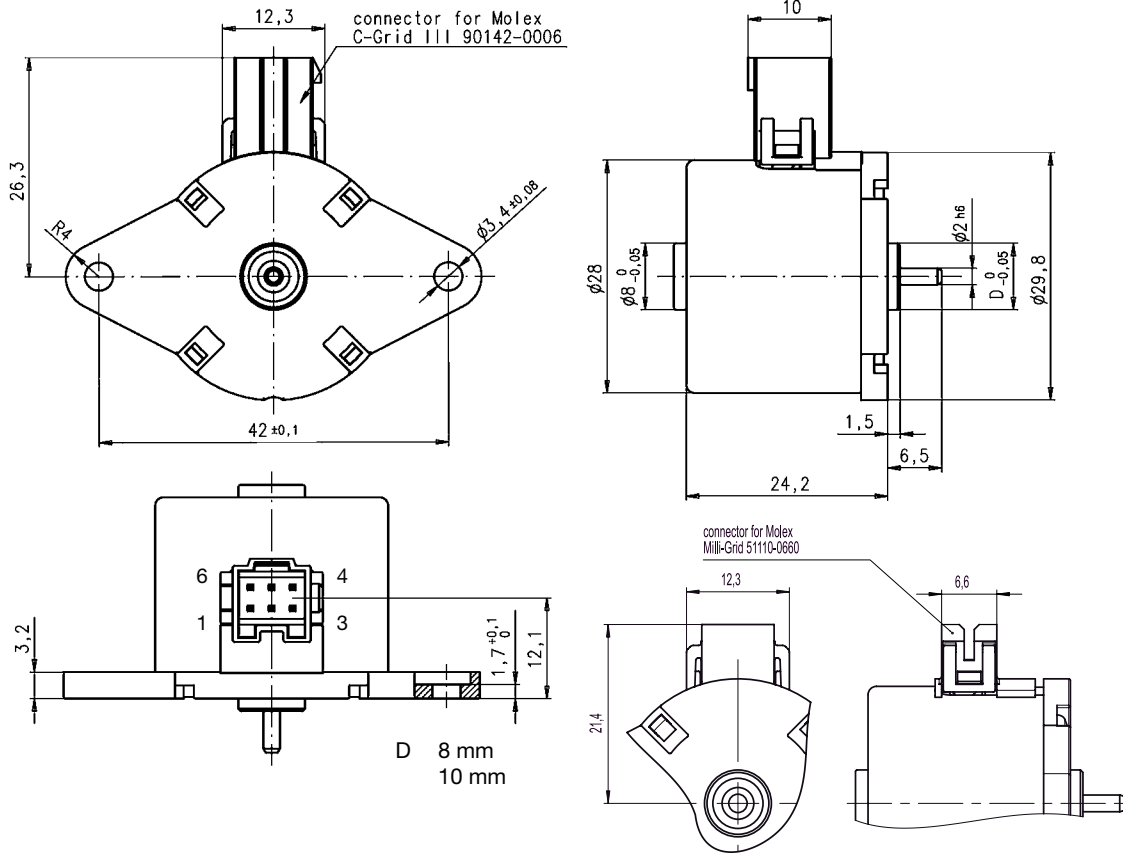

Version with Connector N (Lead wire version)

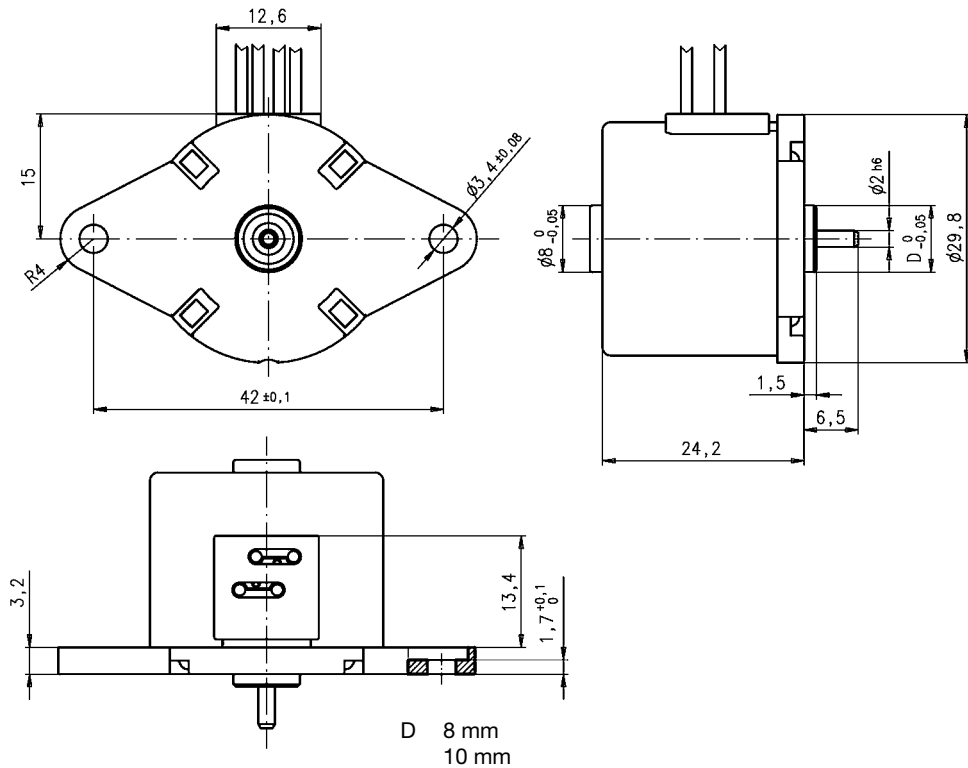

## Performance Chart

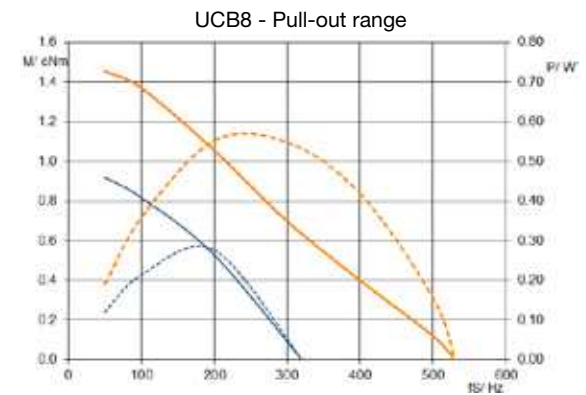
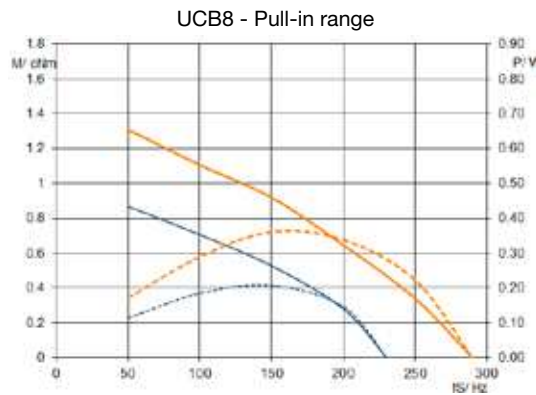
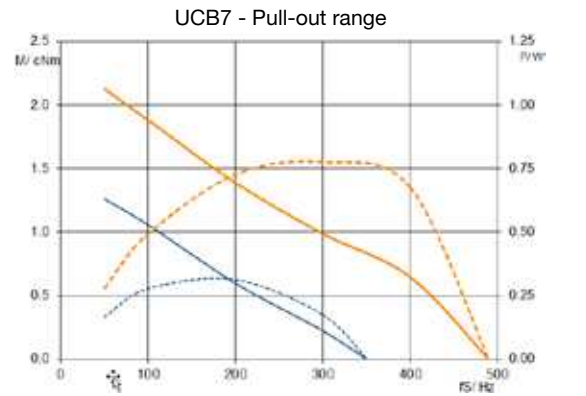
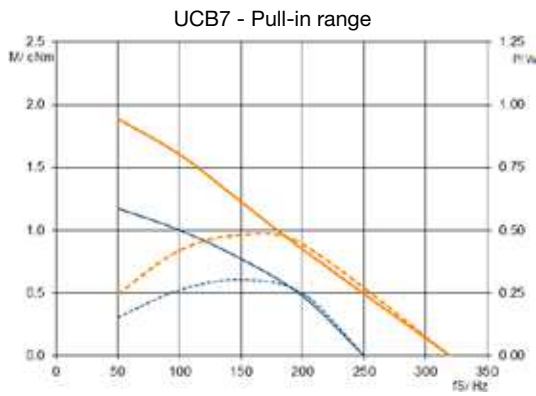
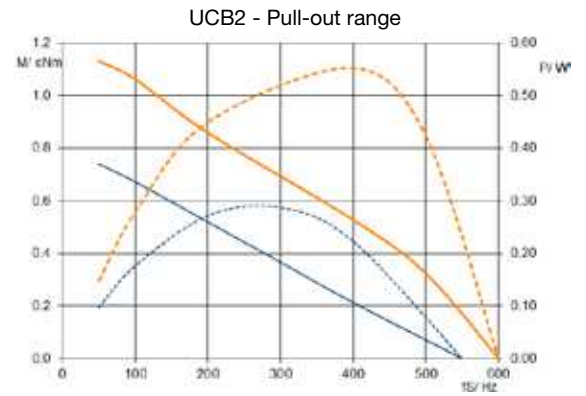
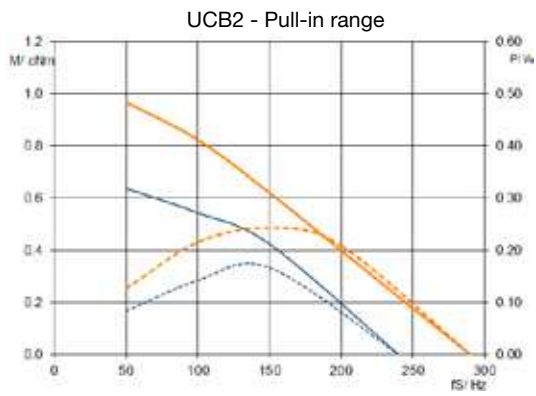
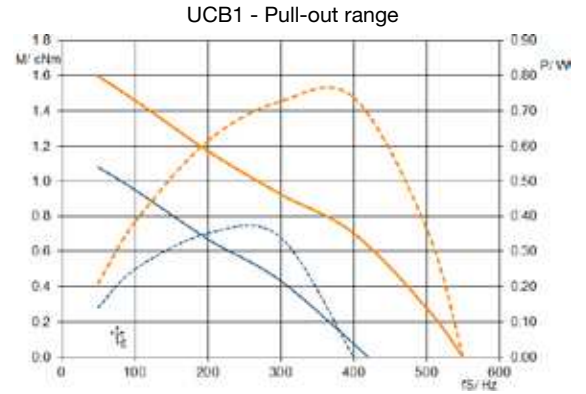
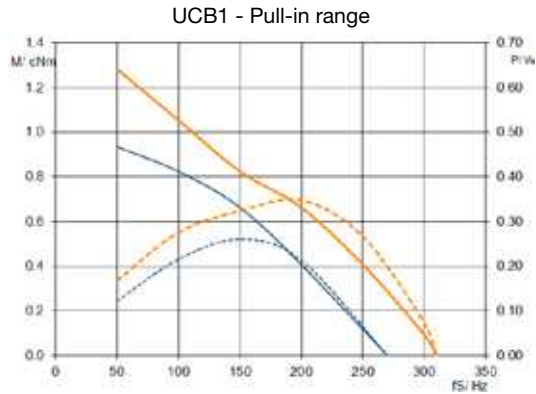

— M - Duty cycle 30 %  
— M - Duty cycle 100%

- - - P - Duty cycle 30 %  
- - - P - Duty cycle 100 %

## UBD1/2/5/6

Dimensions (mm)  $\varnothing$  36 x 21

Step angle (°) 7.5

Holding torque (cNm) 1.1–1.6

Detent torque (cNm) 0.19/0.23

Winding bipolar/unipolar

Gear combination D, M, B, F, V



Note: All torque and power output values are minimum values, at rated voltage and motor temperature 23°C.

### Standard Data

Climatic class	wide-spread according to DIN IEC 60721-2-1 : 2015
Ambient temperature operation	°C -15...+55
Ambient temperature storage	°C -20...+100
Thermal resistance at f=0 R <sub>therm</sub>	27 K/W
Thermal class	105 (A) according to DIN EN 60085 : 2008
Approval	standard (UL/CSA on request)
Mounting	any position
Electrical connection	cable
Protection	IP40 according to DIN EN 60529 : 2014
Weight	60 g
Rotor stalling	motor can be stopped when voltage is applied, without being overheated
Bearings	sintered bronze, self-lubricating
Electric strength	according to DIN EN 60034-1/DIN EN 60335-1

### Order Reference

Type	Stepper Motor		UBD 1 0 N 03 R E					
Configuration	1	bipolar, standard magnet	5	bipolar, stronger magnet				
	2	unipolar, standard magnet	6	unipolar, stronger magnet				
Rotor shaft, mounting	0	centring 8 mm, shaft 2.0 mm, clip	A	centring 10 mm, shaft 2.0 mm, clip				
	1	centring 8 mm, shaft 1.5 mm, clip	C	centring 10 mm, shaft 1.5 mm, clip				
	3	centring 8 mm, shaft 2.0 mm, screw plate	E	centring 10 mm, shaft 2.0 mm, screw plate				
	4	centring 8 mm, shaft 1.5 mm, screw plate	K	centring 10 mm, shaft 1.5 mm, screw plate				
Approval	N	Approval Standard						
Resistance	See next page		Resistance per winding for bipolar or unipolar.					
Direction	reversible							
Cable	E	cable 150 mm (other on request)						

## Technical Data

bipolar			UBD1	UBD5				
Holding torque $M_H$	cNm		1.5	1.6				
Detent torque $M_S$	cNm		0.19	0.23				
Rotor inertia $J_R$	gcm <sup>2</sup>		2.8	2.9				
UBD1/5	Rated voltage $U_N$	V	6	12	24	6	12	24
	Duty cycle	%	100	100	100	100	100	100
	Resistance $R_{20}$	$\Omega$	18.5	100	460	27.5	133	535
	Winding code		03	05	06	01	04	07
unipolar			UBD2	UBD6				
Holding torque $M_H$	cNm		1.1	1.35				
Detent torque $M_S$	cNm		0.19	0.23				
Rotor inertia $J_R$	gcm <sup>2</sup>		2.8	2.9				
UBD2/6	Rated voltage $U_N$	V	6	12	24	6	12	24
	Duty cycle	%	100	100	100	100	100	100
	Resistance $R_{20}$	$\Omega$	28	120	500	41	172	700
	Winding code		07	08	09	01	02	03
UBD3/7	Rated voltage $U_N$	V	6	12	24			
	Duty cycle	%	100	100	100			
	Resistance $R_{20}$	$\Omega$	18.5	100	460			
	Winding code		03	05	06			
UBD4/8	Rated voltage $U_N$	V	6	12	24			
	Duty cycle	%	100	100	100			
	Resistance $R_{20}$	$\Omega$	28	120	500			
	Winding code		07	08	09			
	Steps per revolution		48					
	Winding temperature $T_{max}$	$^{\circ}C$	105					
	Direction of rotation		reversible					

### Dimensions

#### Mounting with screw plate

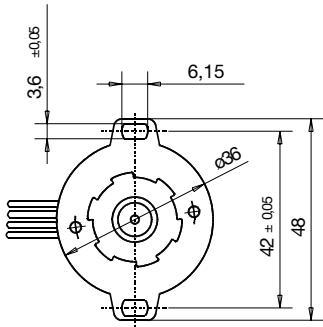

#### Mounting with screw plate

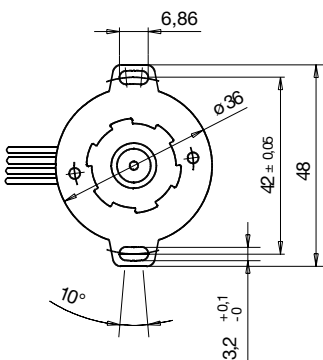

#### Mounting with snap-on clip

(item no. 4199 48230)

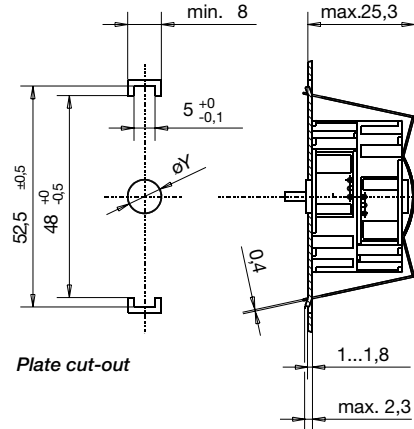

#### Plate cut-out

$\varnothing D$  Rotor shaft

$\varnothing 2$  h6

$\varnothing 1.5$  js8

$\varnothing Z$   $\varnothing Y$

8 8F8

10 10F8

Screw clip: 4199 48450

## Performance Chart

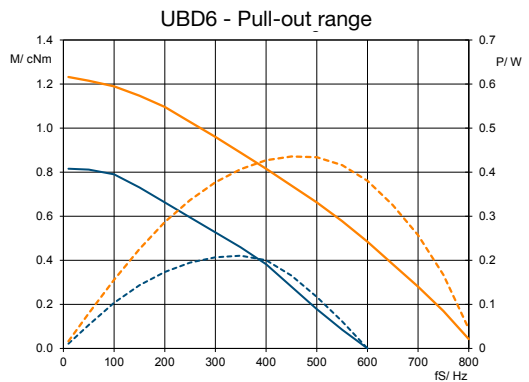
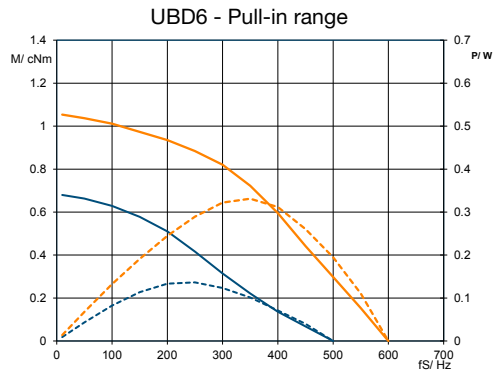
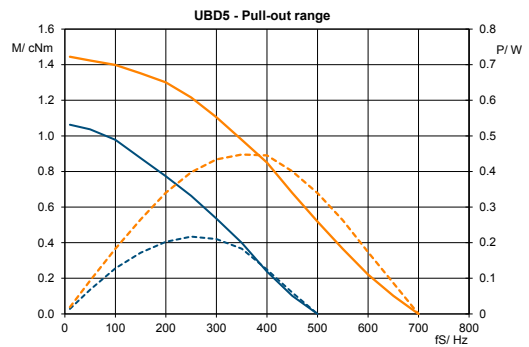
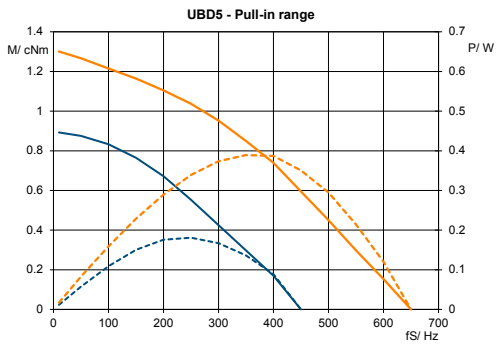
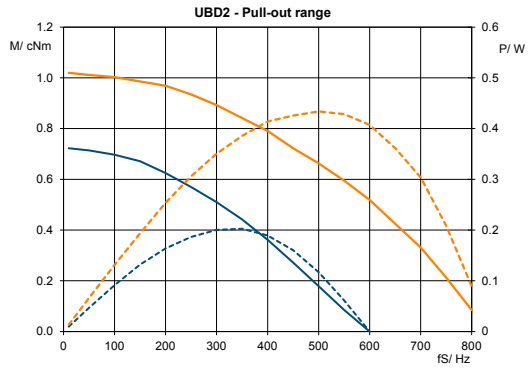
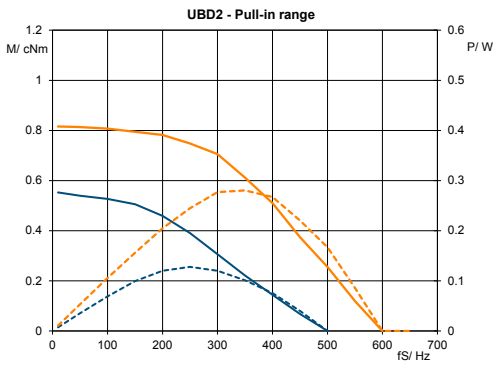
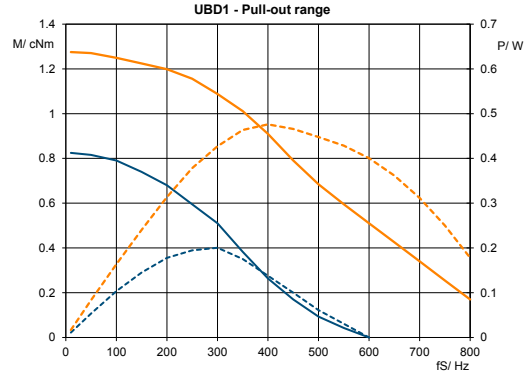
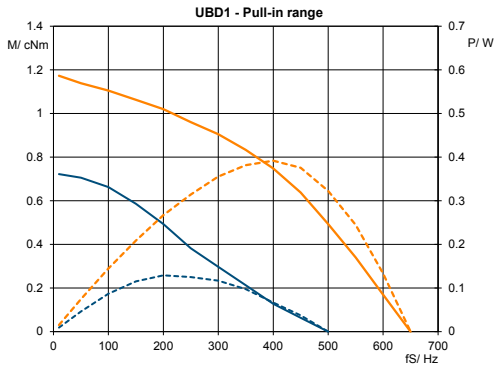

— M - Duty cycle 30 %  
— M - Duty cycle 100 %

- - - P - Duty cycle 30 %  
- - - P - Duty cycle 100 %

## UBB1/2/5/6

Dimensions (mm)	∅ 36 x 21
Step angle (°)	15
Holding torque (cNm)	0.85–1.6
Detent torque (cNm)	0.21/0.31
Winding	bipolar/unipolar
Gear combination	D, M, B, F, V



Note: All torque and power output values are minimum values, at rated voltage and motor temperature 23°C.

## Standard Data

Climatic class	wide-spread according to DIN IEC 60721-2-1 : 2015
Ambient temperature operation	°C -15...+55
Ambient temperature storage	°C -20...+100
Thermal resistance at f=0 R <sub>therm</sub>	27 K/W
Thermal class	105 (A) according to DIN EN 60085 : 2008
Approval	standard (UL/CSA on request)
Mounting	any position
Electrical connection	cable
Protection	IP40 according to DIN EN 60529 : 2014
Weight	60 g
Rotor stalling	motor can be stopped when voltage is applied, without being overheated
Bearings	sintered bronze, self-lubricating
Electric strength	according to DIN EN 60034-1/DIN EN 60335-1

## Order Reference

Type	Stepper Motor		UBB	1	0	N	03	R	E
Configuration	1 bipolar, standard magnet	5 bipolar, stronger magnet							
	2 unipolar, standard magnet	6 unipolar, stronger magnet							
Rotor shaft, mounting	0 centring 8 mm, shaft 2.0 mm, clip	A centring 10 mm, shaft 2.0 mm, clip							
	1 centring 8 mm, shaft 1.5 mm, clip	C centring 10 mm, shaft 1.5 mm, clip							
	3 centring 8 mm, shaft 2.0 mm, screw plate	E centring 10 mm, shaft 2.0 mm, screw plate							
	4 centring 8 mm, shaft 1.5 mm, screw plate	K centring 10 mm, shaft 1.5 mm, screw plate							
Approval	N Approval Standard								
Resistance	See next page Resistance per winding for bipolar or unipolar.								
Direction	reversible								
Cable	E cable 150 mm (other on request)								

All specifications are representative only and maybe subject to variation. For confirmation of values, please contact Johnson Electric. Please also read "Saia Motors Important Notes" on catalog or at [www.johnsonelectric.com/SaiaMotorsNotes](http://www.johnsonelectric.com/SaiaMotorsNotes)

## Technical Data

		UBB1	UBB5
bipolar			
	Holding torque $M_H$	cNm	1.3
	Detent torque $M_S$	cNm	0.21
	Rotor inertia $J_R$	gcm <sup>2</sup>	2.8
UBB1/5	Rated voltage $U_N$	V	6
	Duty cycle	%	100
	Resistance $R_{20}$	$\Omega$	18.5
	Winding code		03
			05
			06
unipolar		UBB2	UBB6
	Holding torque $M_H$	cNm	0.85
	Detent torque $M_S$	cNm	0.21
	Rotor inertia $J_R$	gcm <sup>2</sup>	2.8
UBB2/6	Rated voltage $U_N$	V	6
	Duty cycle	%	100
	Resistance $R_{20}$	$\Omega$	28
	Winding code		07
			08
			09
UBB3/7	Rated voltage $U_N$	V	6
	Duty cycle	%	100
	Resistance $R_{20}$	$\Omega$	18.5
	Winding code		03
			05
			06
UBB4/8	Rated voltage $U_N$	V	6
	Duty cycle	%	100
	Resistance $R_{20}$	$\Omega$	28
	Winding code		07
			08
			09
	Steps per revolution		24
	Winding temperature $T_{max}$	$^{\circ}C$	105
	Direction of rotation		reversible

### Dimensions Mounting with screw plate

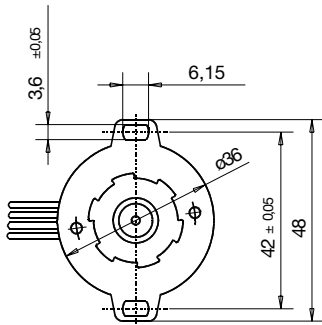

### Mounting with screw plate

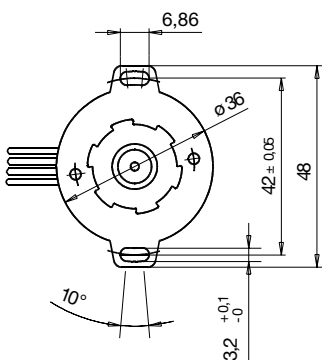

### Mounting with snap-on clip (item no. 4199 48230)

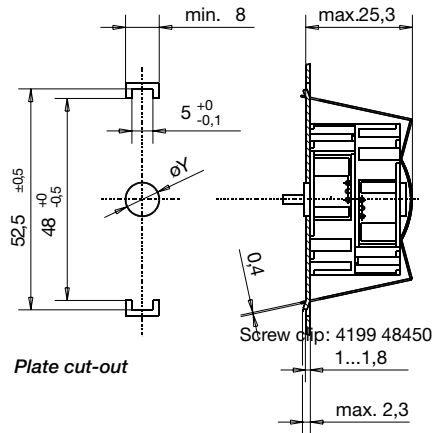

### Plate cut-out

#### øD Rotor shaft

ø 2 h6

ø 1.5 js8

øZ øY

8 8F8

10 10F8

## Performance Chart

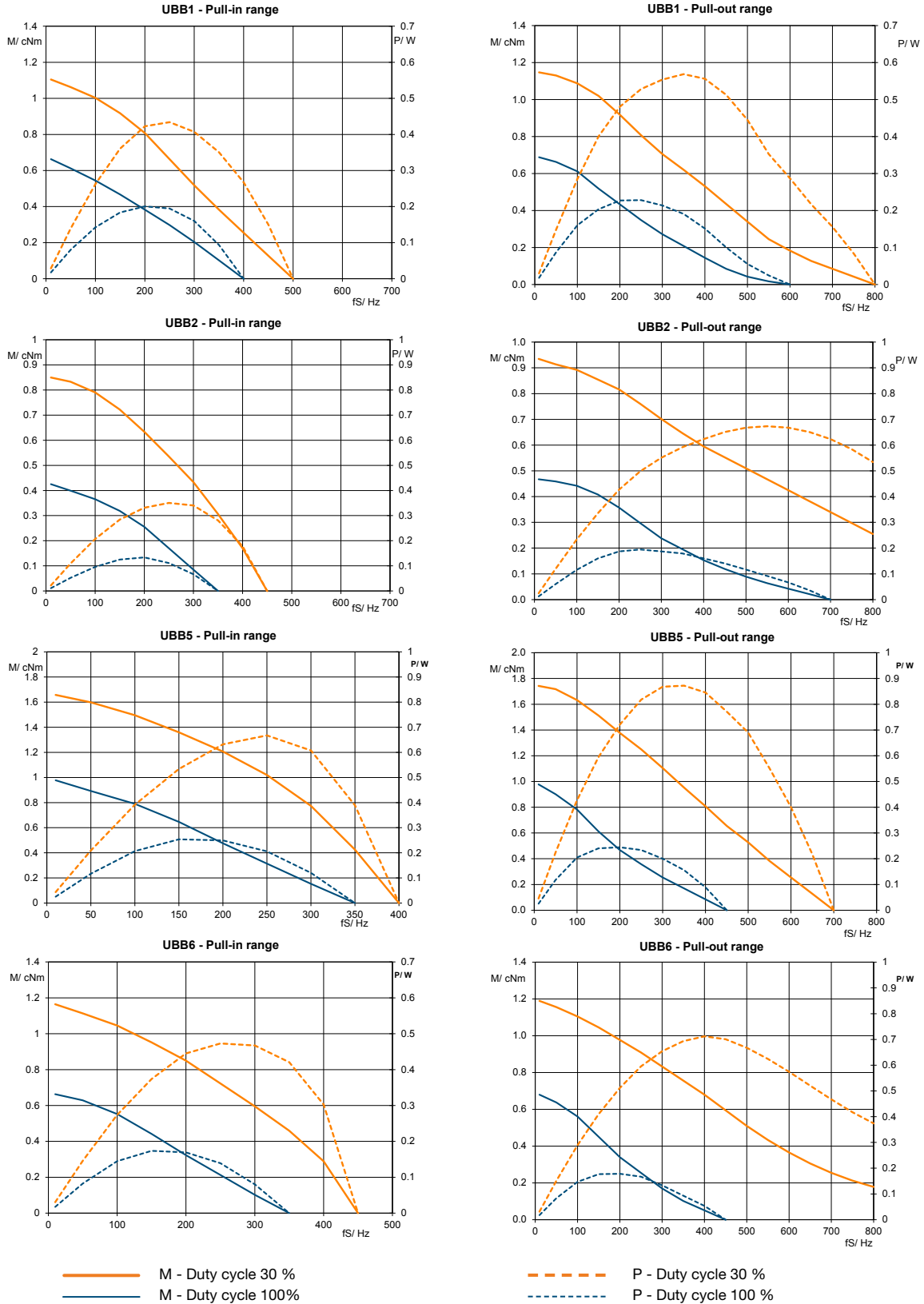



## UDB1/2

Dimensions (mm)	∅ 48 x 24
Step angle (°)	15
Holding torque (cNm)	2.3/1.8
Detent torque (cNm)	0.3
Winding	bipolar/unipolar
Gear combination	D, M, B, F, V, J

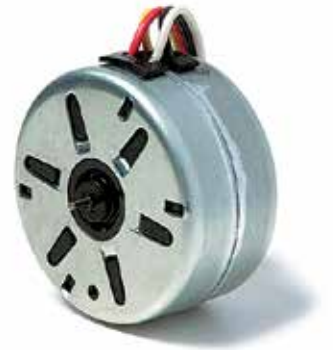

Note: All torque and power output values are minimum values, at rated voltage and motor temperature 23°C.

### Standard Data

Climatic class	wide-spread according to DIN IEC 60721-2-1 : 2015
Ambient temperature operation	°C -15...+60
Ambient temperature storage	°C -20...+100
Thermal resistance at f=0 R <sub>therm</sub>	18 K/W
Thermal class	105 (A) according to DIN EN 60085 : 2008
Approval	standard
Mounting	any position
Electrical connection	cable
Protection	UDB1: IP30, UDB2: IP40 according to DIN EN 60529 : 2014
Weight	132 g
Rotor stalling	motor can be stopped when voltage is applied, without being overheated
Bearings	sintered bronze, self-lubricating
Electric strength	according to DIN EN 60034-1/DIN EN 60335-1

### Order Reference

Type	Stepper Motor	UDB	1	0	N	02	R	N
Configuration	1 bipolar 2 unipolar							
Rotor shaft, mounting	0 centring 8 mm, shaft 1.5 mm, clip 1 centring 8 mm, shaft 2.0 mm, clip							
Approval	N Approval Standard							
Resistance	See next page Resistance per winding for bipolar or unipolar.							
Direction	reversible							
Cable	N cable 150 mm (other on request)							

## Technical Data

bipolar (UDB1)	Holding torque $M_H$	cNm	2.3		
	Detent torque $M_S$	cNm	0.3		
	Rotor inertia $J_R$	gcm <sup>2</sup>	6.3		
	Rated voltage $U_N$	V	6	12	24
	Duty cycle	%	100	100	100
	Resistance $R_{20}$	$\Omega$	15	78	350
	Winding code		01	02	03
unipolar (UDB2)	Holding torque $M_H$	cNm	1.8		
	Detent torque $M_S$	cNm	0.3		
	Rotor inertia $J_R$	gcm <sup>2</sup>	6.3		
	Rated voltage $U_N$	V	6	12	24
	Duty cycle	%	100	100	100
	Resistance $R_{20}$	$\Omega$	19	75	300
	Winding code		01	02	04
Steps per revolution			24		
Winding temperature $T_{max}$		$^{\circ}C$	105		
Direction of rotation			reversible		

### Dimensions

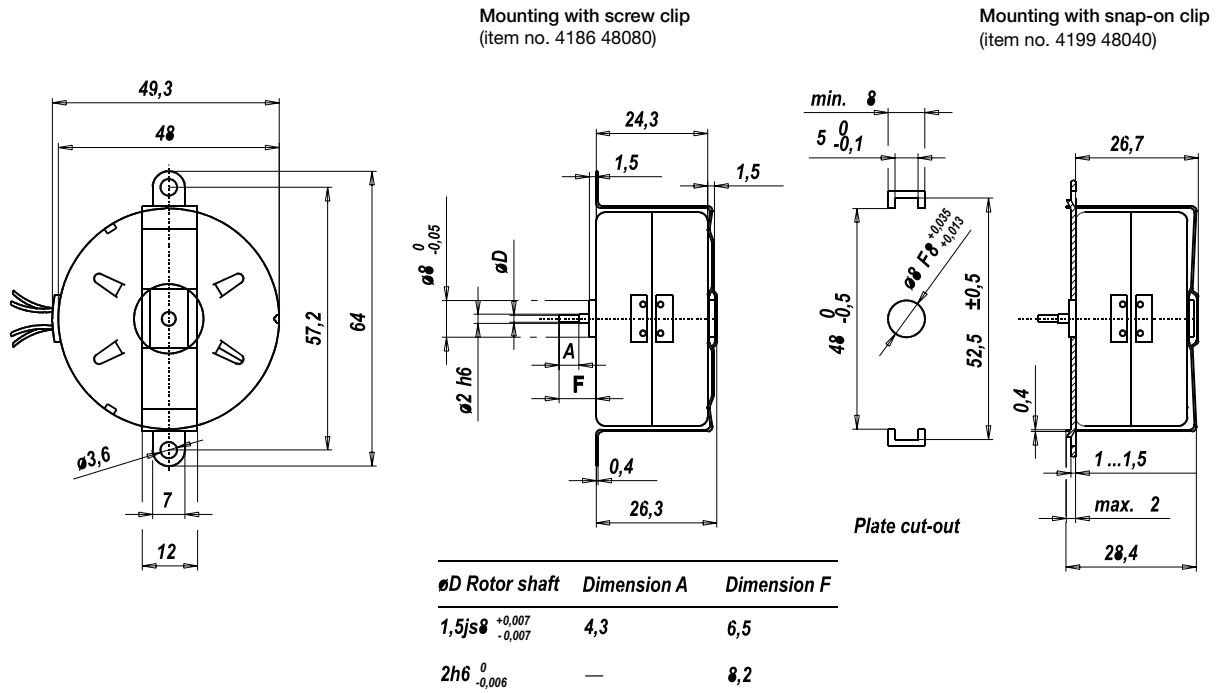

## Performance Chart

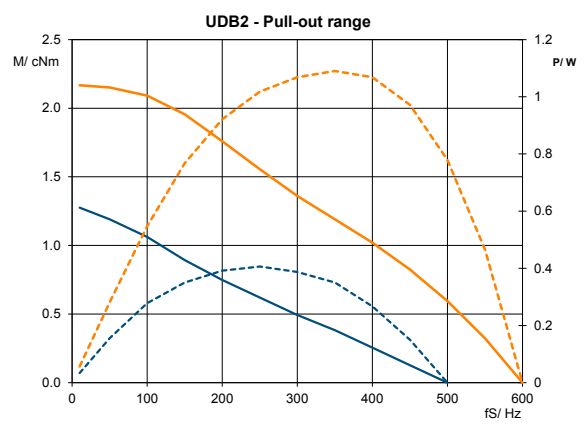
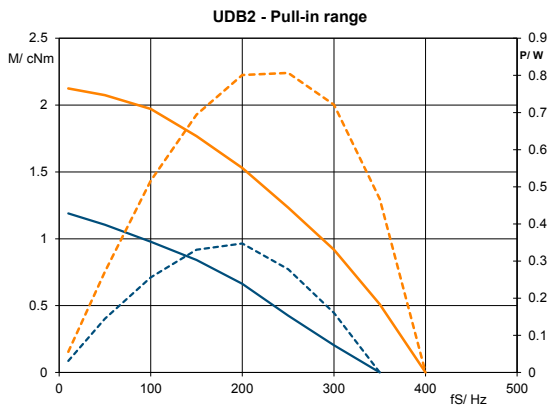
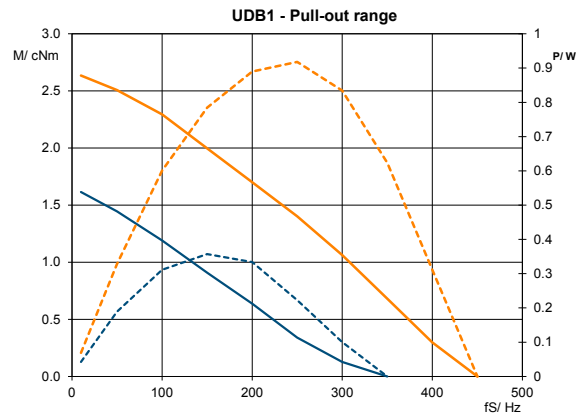
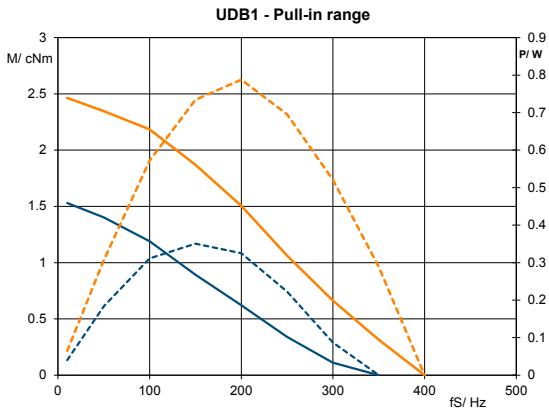

— M - Duty cycle 30 %  
— M - Duty cycle 100%

- - - P - Duty cycle 30 %  
- - - P - Duty cycle 100 %

## UFD1/2

Dimensions (mm)	∅ 52 x 28
Step angle (°)	7.5
Holding torque (cNm)	5.4/3.9
Detent torque (cNm)	0.38
Winding	bipolar/unipolar
Gear combination	D, M, B, F, V, J, O, P

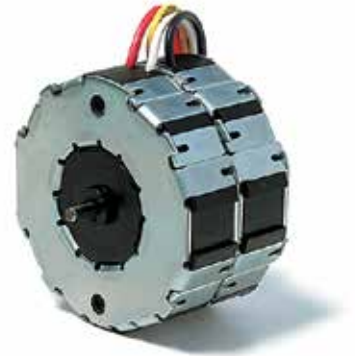

Note: All torque and power output values are minimum values, at rated voltage and motor temperature 23°C.

## Standard Data

Climatic class	wide-spread according to DIN IEC 60721-2-1 : 2015
Ambient temperature operation	°C -15...+55
Ambient temperature storage	°C -20...+100
Thermal resistance at f=0 R <sub>therm</sub>	13 K/W
Thermal class	105 (A) according to DIN EN 60085 : 2008 (130 / B on request)
Approval	standard (UL/CSA on request)
Mounting	any position
Electrical connection	lead wires AWG22, insulation ∅ 1.72 ± 0.08 mm
Protection	IP40 according to DIN EN 60529 : 2014
Weight	180 g
Rotor stalling	motor can be stopped when voltage is applied, without being overheated
Bearings	sintered bronze, self-lubricating
Electric strength	according to DIN EN 60034-1/DIN EN 60335-1

## Order Reference

Type	Stepper Motor						UFD	1	0	N	02	R	N
Configuration	1	bipolar, two coils											
	2	unipolar, two coils											
Rotor shaft, mounting	0	centring 8 mm, shaft 3.0 mm, clip	E	centring 10 mm, shaft 3.0 mm, screw plate									
	1	centring 8 mm, shaft 2.0 mm, clip	K	centring 10 mm, shaft 2.0 mm, screw plate									
	2	centring 8 mm, shaft 1.5 mm, clip	M	centring 10 mm, shaft 1.5 mm, screw plate									
	3	centring 8 mm, shaft 3.0 mm, screw plate	B	centring 10 mm, shaft 3.0 mm, clip									
	4	centring 8 mm, shaft 2.0 mm, screw plate	A	centring 10 mm, shaft 2.0 mm, clip									
	5	centring 8 mm, shaft 1.5 mm, screw plate	C	centring 10 mm, shaft 1.5 mm, clip									
Approval	N	Approval Standard											
Resistance	See next page Resistance per winding for bipolar or unipolar.												
Direction	reversible												
Cable	E cable 150 mm (other on request)												

All specifications are representative only and maybe subject to variation. For confirmation of values, please contact Johnson Electric. Please also read "Saia Motors Important Notes" on catalog or at [www.johnsonelectric.com/SaiaMotorsNotes](http://www.johnsonelectric.com/SaiaMotorsNotes)

## Technical Data

bipolar (UFD1)	Holding torque $M_H$	cNm	5.4		
	Detent torque $M_S$	cNm	0.38		
	Rotor inertia $J_R$	gcm <sup>2</sup>	14.4		
	Rated voltage $U_N$	V	6	12	24
	Duty cycle	%	100	100	100
	Resistance $R_{20}$	$\Omega$	9.5	52	250
	Winding code		01	02	03
unipolar (UFD2)	Holding torque $M_H$	cNm	3.9		
	Detent torque $M_S$	cNm	0.38		
	Rotor inertia $J_R$	gcm <sup>2</sup>	14.4		
	Rated voltage $U_N$	V	6	12	24
	Duty cycle	%	100	100	100
	Resistance $R_{20}$	$\Omega$	15	61	251
	Winding code		01	02	03
	Steps per revolution		48		
	Winding temperature $T_{max}$	$^{\circ}C$	105		
	Direction of rotation		reversible		
Rotor shaft		3, $\varnothing D = 3h6$ , Dim. A = „-“			

### Dimensions

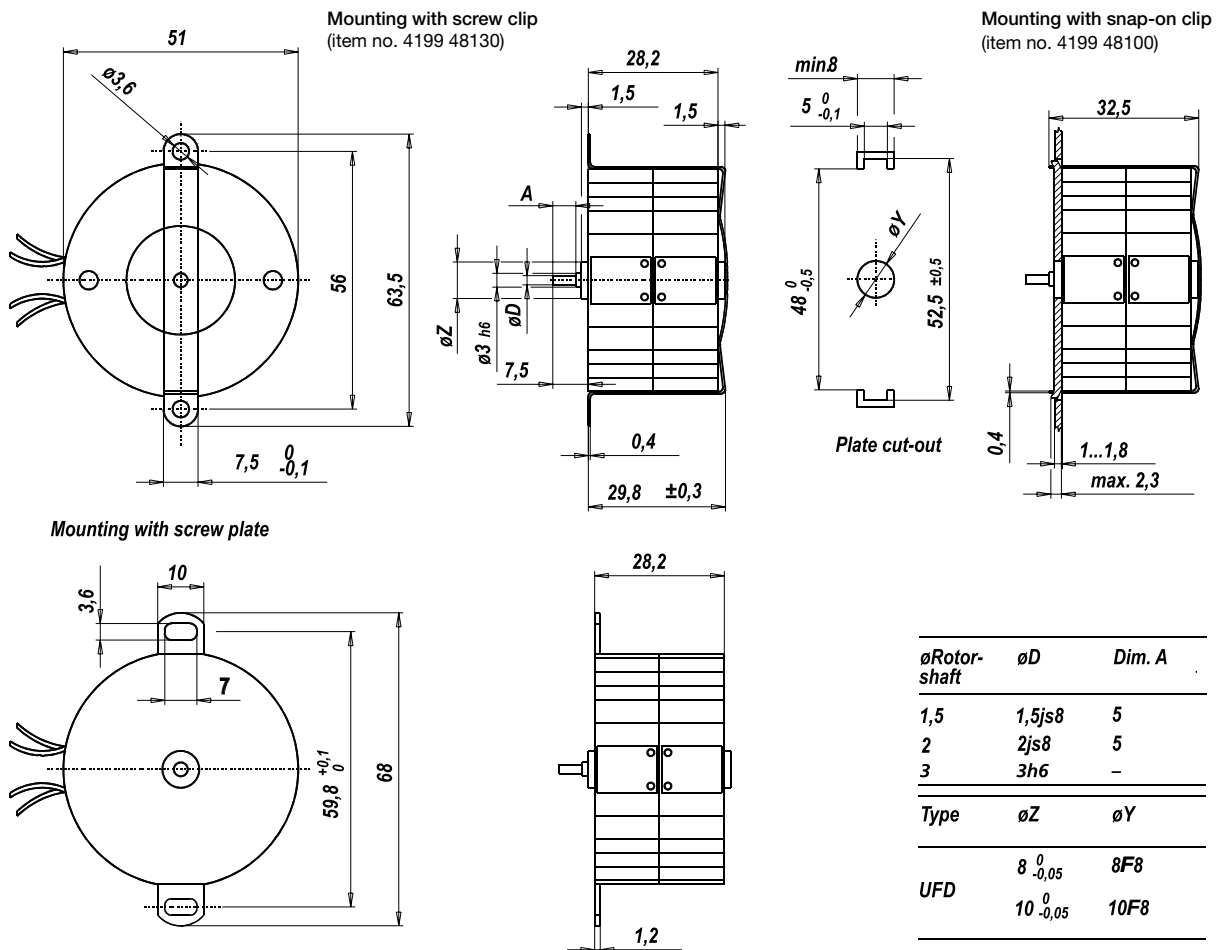

## Performance Chart

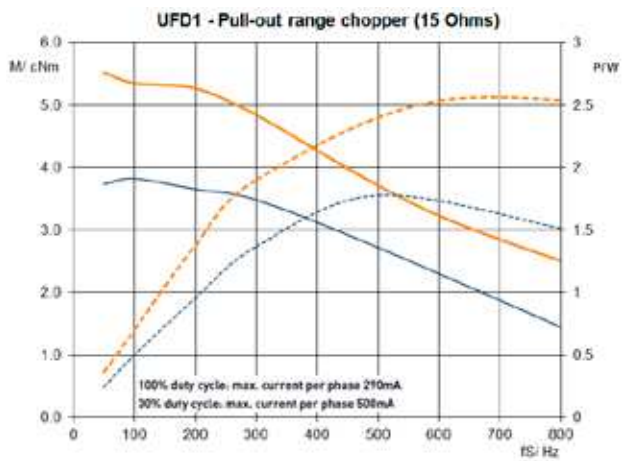
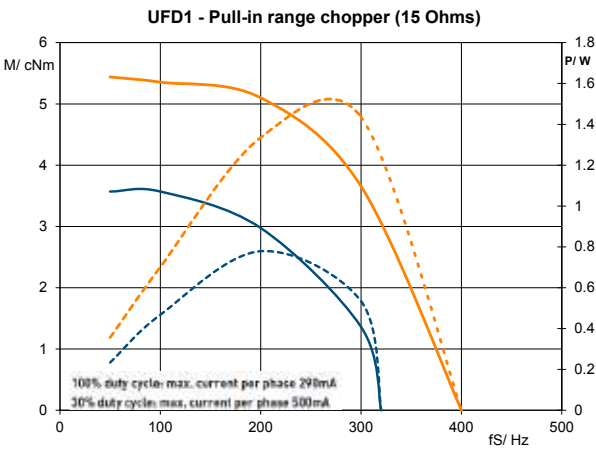
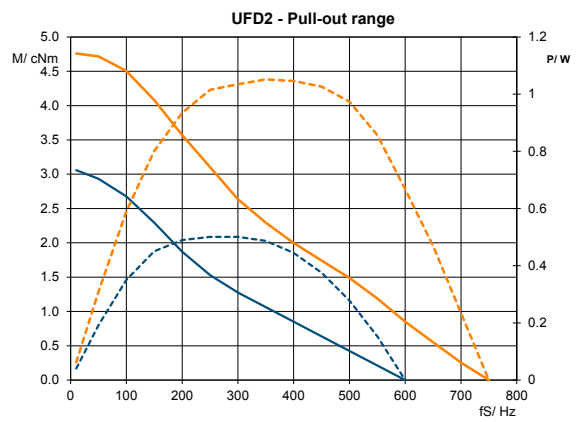
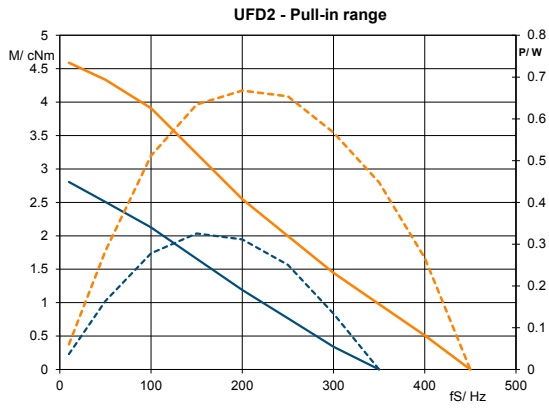
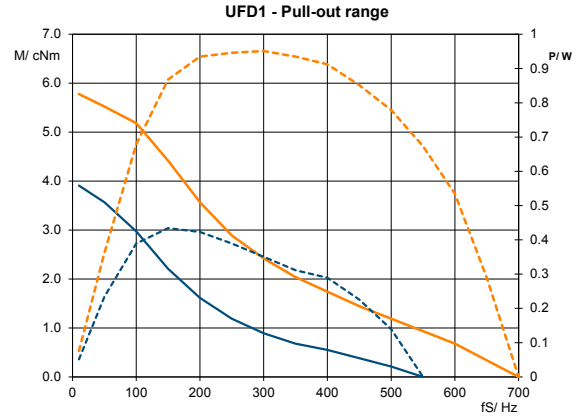
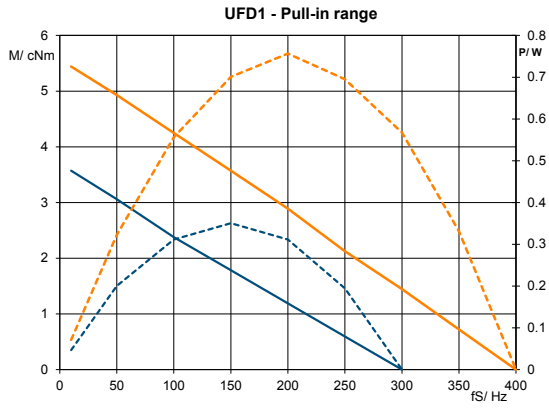

— M - Duty cycle 30 %  
— M - Duty cycle 100%

--- P - Duty cycle 30 %  
--- P - Duty cycle 100 %

## UFB1/2/5; UFB3/4

Dimensions (mm)	∅ 52 x 28 / ∅ 52 x 56
Step angle (°)	15
Holding torque (cNm)	3.7–4.7 (UFB1/2); 7.0 (UFB5); 6.5–8.8 (UFB3/4)
Detent torque (cNm)	0.4 (UFB1/2); 0.68 (UFB5); 0.68 (UFB3/4)
Winding	bipolar/unipolar
Gear combination	D, M, B, F, V, J, O, P

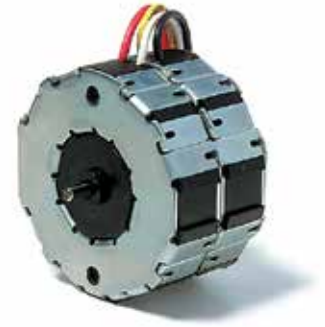

Note: All torque and power output values are minimum values, at rated voltage and motor temperature 23°C.

### Standard Data

Climatic class	wide-spread according to DIN IEC 60721-2-1 : 2015
Ambient temperature operation	°C -15...+55
Ambient temperature storage	°C -20...+100
Thermal resistance at f=0 R <sub>therm</sub>	11 K/W (UFB1/2/5), 7 K/W (UFB3/4)
Thermal class	105 (A) according to DIN EN 60085 : 2008 [130 (B) on request]
Approval	standard (UL/CSA on request)
Mounting	any position
Electrical connection	lead wires AWG22, insulation ∅ 1.75 ± 0.08 mm
Protection	IP40 according to DIN EN 60529 : 2014
Weight	180 g (UFB1/2/5), 350 g (UFB3/4)
Rotor stalling	motor can be stopped when voltage is applied, without being overheated
Bearings	sintered bronze, self-lubricating
Electric strength	according to DIN EN 60034-1/DIN EN 60335-1

### Order Reference

Type	Stepper Motor		UFB		1	0	N	01	R	N
Configuration	1	bipolar, two coils, standard magnet	3	bipolar, four coils, standard magnet						
	2	unipolar, two coils, standard magnet	4	unipolar, four coils, standard magnet						
	5	bipolar, two coils, stronger magnet								
Rotor shaft, mounting	0	centring 8 mm, shaft 3.0 mm, clip	E	centring 10 mm, shaft 3.0 mm, screw plate *						
	1	centring 8 mm, shaft 2.0 mm, clip	K	centring 10 mm, shaft 2.0 mm, screw plate *						
	2	centring 8 mm, shaft 1.5 mm, clip	M	centring 10 mm, shaft 1.5 mm, screw plate *						
	3	centring 8 mm, shaft 3.0 mm, screw plate *	B	centring 10 mm, shaft 3.0 mm, clip						
	4	centring 8 mm, shaft 2.0 mm, screw plate *	A	centring 10 mm, shaft 2.0 mm, clip						
	5	centring 8 mm, shaft 1.5 mm, screw plate *	C	centring 10 mm, shaft 1.5 mm, clip						
Approval	N	Approval Standard								
Winding code		see next page								
Direction		reversible								
Cable	N	cable 150 mm (other on request)								

\* screw plate not for UFB3 and UFB4

## Technical Data

		UFB1	UFB3	UFB5	
bipolar					
	Holding torque $M_H$	cNm	4.7	8.8	7.0
	Detent torque $M_S$	cNm	0.4	0.68	0.68
	Rotor inertia $J_R$	$\text{gcm}^2$	14.2	24.2	17.8
UFB1/5	Rated voltage $U_N$	V	6	12	24
	Duty cycle	%	100	100	100
	Resistance $R_{20}$	$\Omega$	9.5	52	250
	Winding code		01	02	04
UFB3	Rated voltage $U_N$	V	6	12	24
	Duty cycle	%	100	100	100
	Resistance $R_{20}$	$\Omega$	5	25.5	125
	Winding code		01	02	04
unipolar		UFB2	UFB4		
	Holding torque $M_H$	cNm	3.7	6.5	
	Detent torque $M_S$	cNm	0.4	0.68	
	Rotor inertia $J_R$	$\text{gcm}^2$	14.2	24.2	
UFB2	Rated voltage $U_N$	V	6	12	24
	Duty cycle	%	100	100	100
	Resistance $R_{20}$	$\Omega$	15	61	251
	Winding code		01	02	03
UFB4	Rated voltage $U_N$	V	6	12	24
	Duty cycle	%	100	100	100
	Resistance $R_{20}$	$\Omega$	7.5	30.5	125
	Winding code		01	02	03
	Steps per revolution	24			
	Winding temperature $T_{\max}$	105° C			
	Direction of rotation	reversible			



## Dimensions

UFB1/2/5

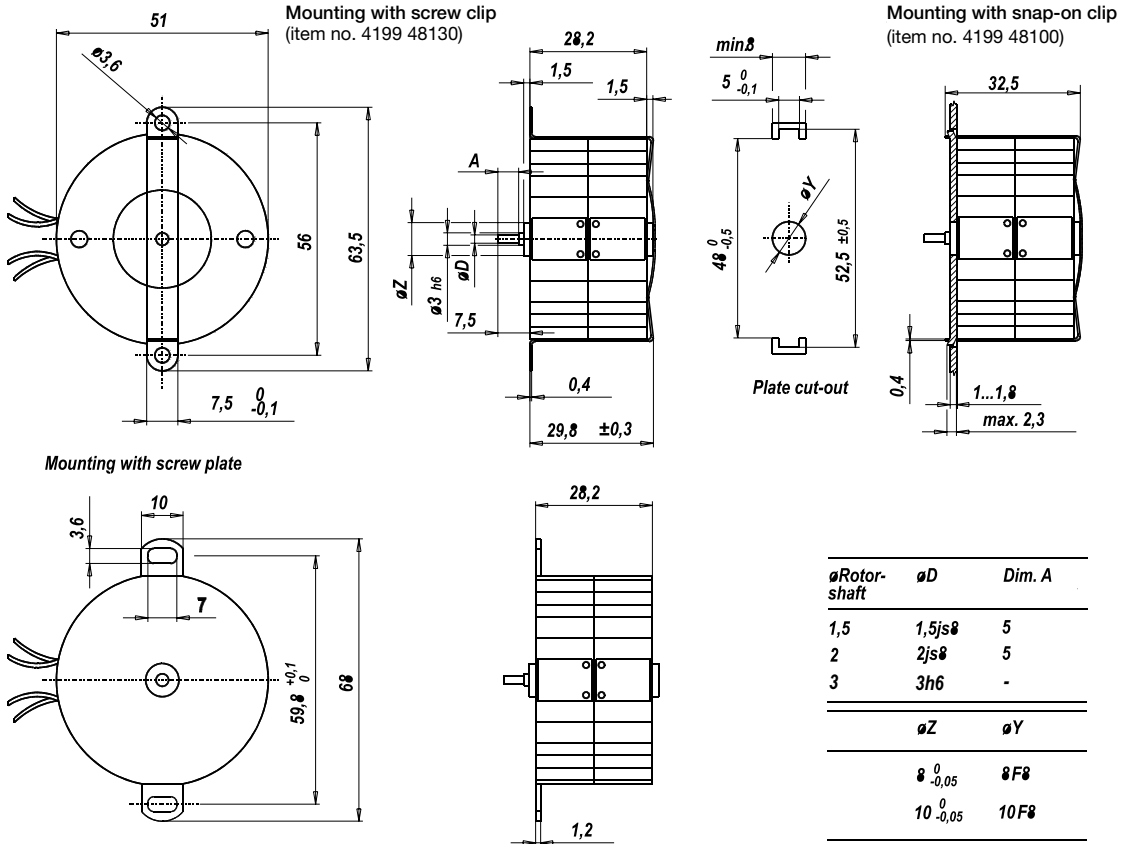

UFB3/4

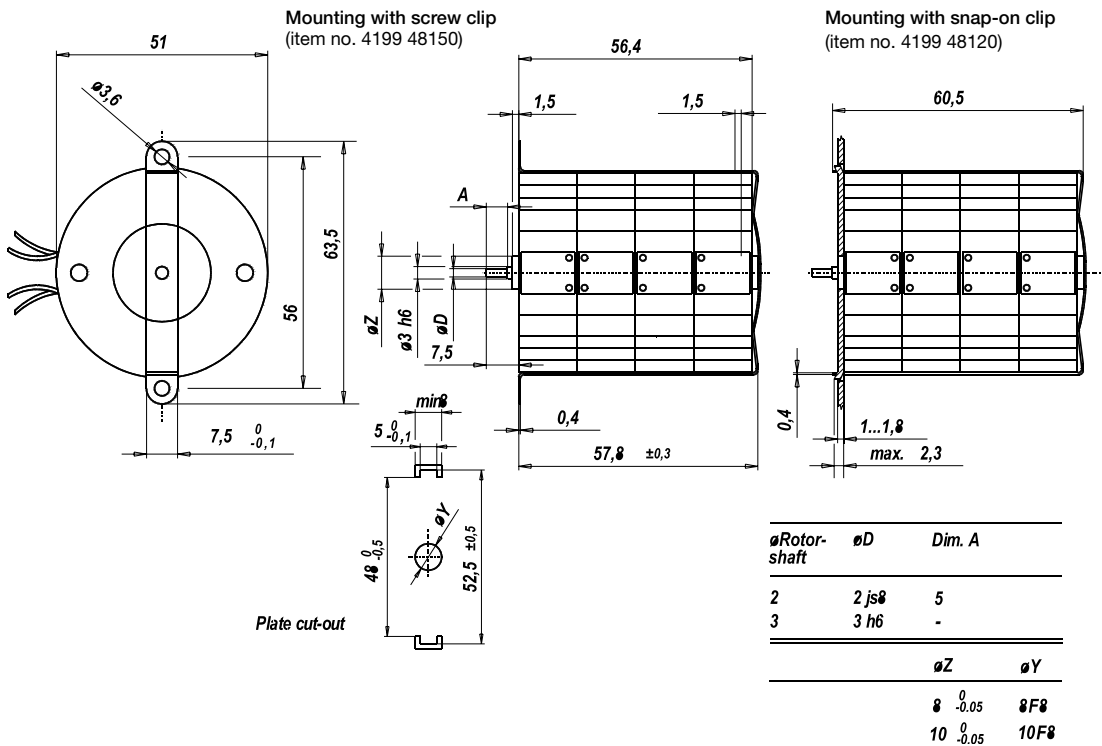

## Performance Chart

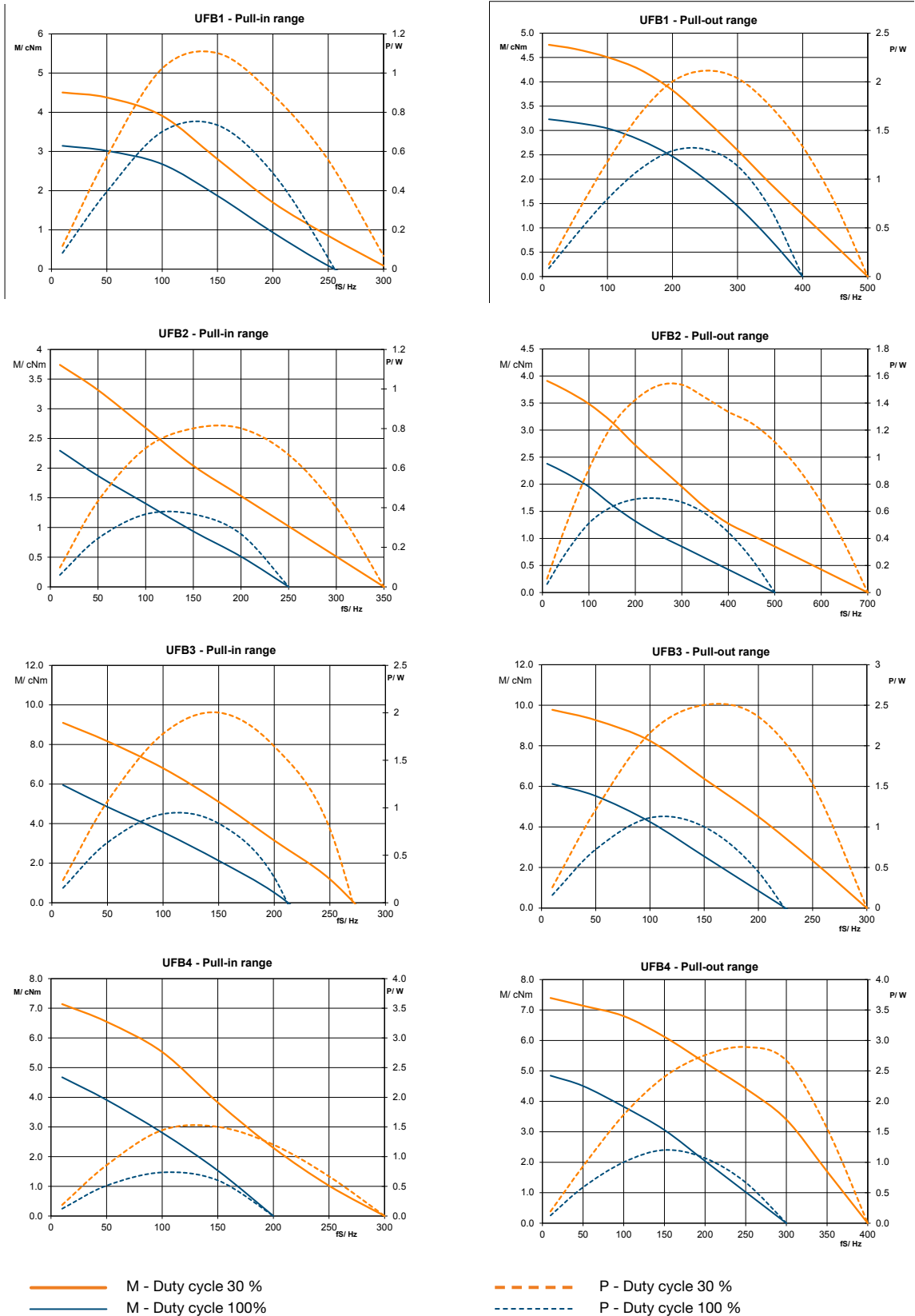

## Performance Chart

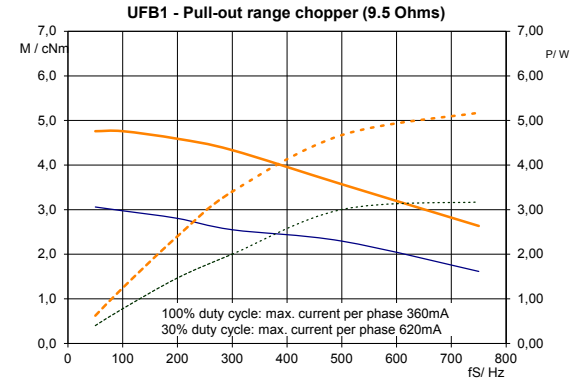
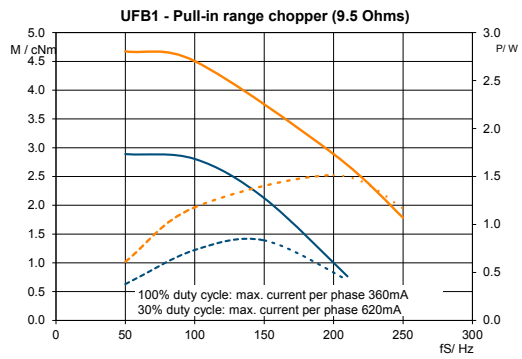
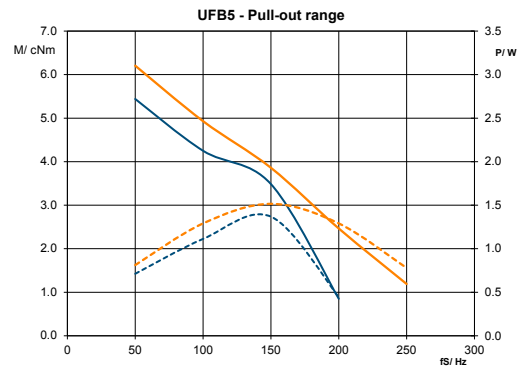
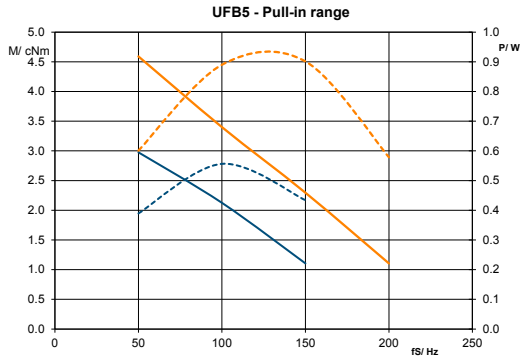

— M - Duty cycle 30 %  
 — M - Duty cycle 100%

- - - P - Duty cycle 30 %  
 - - - P - Duty cycle 100 %

## UPJ

Dimensions (mm)	∅ 64 x 43
Step angle (°)	11.25
Holding torque (cNm)	30 (UPJ1); 45 (UPJ5)
Detent torque (cNm)	2 (UPJ1); 7 (UPJ5)
Winding	bipolar
Gear combination	O, P, R



Note: All torque and power output values are minimum values, at rated voltage and motor temperature 23°C.

## Standard Data

Climatic class	wide-spread according to DIN IEC 60721-2-1 : 2015
Ambient temperature operation	°C -15 ... +40
Ambient temperature storage	°C -20 ... +100
Thermal resistance at f=0 R <sub>therm</sub>	29 K/W
Thermal class	130 (B) according to DIN EN 60085 : 2008
Approval	standard
Mounting	any position
Electrical connection	lead wires AWG22, insulation ∅ 1.6 ± 0.1 mm
Protection	IP30 according to DIN EN 60529 : 2014
Weight	500 g (UPJ1); 550 g (UPJ5)
Rotor stalling	motor can be stopped when voltage is applied, without being overheated
Bearings	Sintered bronze, self-lubricating

## Order Reference

Type	Stepper Motor	UPJ	1	1	N	01	R	E
Configuration	1 standard magnet 5 stronger magnet							
Rotor shaft, mounting	1 centring 10 mm, shaft length 8,1 mm, screw plate 2 centring 10 mm, shaft length 15,5 mm, screw plate A centring 14 mm, shaft length 8,1 mm, screw plate C centring 14 mm, shaft length 15,5 mm, screw plate							
Approval	N standard							
Winding code	see next page							
Direction	R reversible							
Cable	E 150 mm (other upon request)							

All specifications are representative only and maybe subject to variation. For confirmation of values, please contact Johnson Electric.  
Please also read "Saia Motors Important Notes" on catalog or at [www.johnsonelectric.com/SaiaMotorsNotes](http://www.johnsonelectric.com/SaiaMotorsNotes)

## Technical Data

bipolar (UPJ1)	Step angle	°	11.25
	Holding torque MH	cNm	30
	Detent torque Ms	cNm	2
	Rotor inertia JR	gcm <sup>2</sup>	85
	Steps per revolution		32
	Winding temperature increase	K	90
	Current per winding	A	1.25
	Inductance per winding	mH	9.5
	Power consumption	W	11.5
	Driver mode		Chopper drive

bipolar (UPJ5)	Step angle	°	11.25
	Holding torque MH	cNm	45
	Detent torque Ms	cNm	7
	Rotor inertia JR	gcm <sup>2</sup>	180
	Steps per revolution		32
	Winding temperature increase	K	90
	Current per winding	A	1.25
	Inductance per winding	mH	8
	Power consumption	W	11.5
	Driver mode		Chopper drive
Rated voltage U <sub>N</sub>	V	4.5	
Duty cycle	%	100	
Resistance R <sub>20</sub>	Ω	3.7	
Winding code		01	

Circuit diagram Motor connections - bipolar

lead wire color	step			
	I	II	III	IV
red	+	+	-	-
blue	-	-	+	+
black	-	+	+	-
brown	+	-	-	+

→ clockwise rotation

← counter-clockwise rotation

Dimensions mounting dimensions UP with screw plate

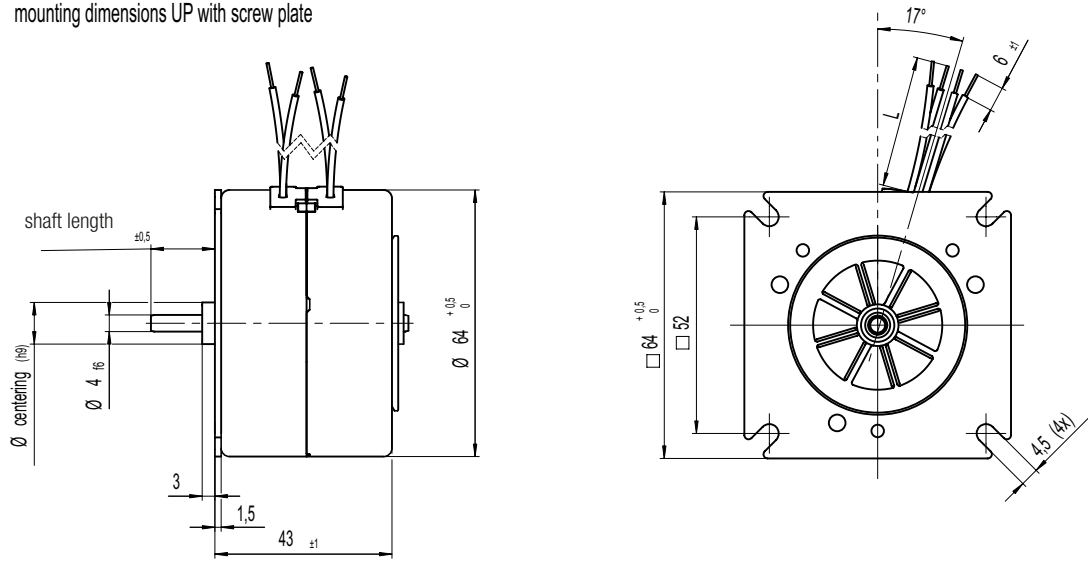

# Gearboxes for Motors

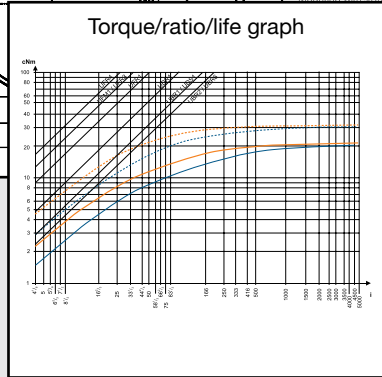
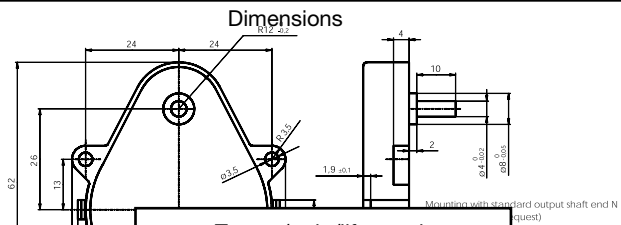

## Planetary Gearbox UGY

Dimensions (mm)	∅ 20* x 12,7 ... 27,7
Max. torque (cNm)	30 (higher torque on request)
Ratios	4,4 ... 370 (3,8 ... 850 on request)
Standard shaft (mm)	∅ 4 with flat (others on request)
Motor combination	Stepper/Synchronous motor UA ; DC motor NF213G Other motors on requests
	* at connection ribs larger



## Standard Data

Mounting	any position
Axial thrust FA	5 N
Lateral force FR	10 N (higher force on request)
Climatic class	wide spread according to DIN IEC 60721-2-1
Ambient temperature operation	°C -10 ... +55
Ambient temperature storage	°C -20 ... +80
Weight	50 ...70 g (with DC motor NF213G)
Bearing	sintered bronze, self-lubricating (ball bearing on request)

## Order Reference

Example motor combination: with DC motor NF

Motor type	JP	DC Motor (brushed)	JP	2	C	N	M4	Y	04A	N	E	N
Motor size	2	diameter 24.2 mm										
Motor version	C	24 V; no-load speed 5900 rpm										
Approval	N	standard										
Voltage	M4	24 Vdc										
Gearbox size	Y	planetary gearbox diameter 20 mm										
Gear ratio	04A	4,4 (1 stage)										
Connection	N	standard										
	A	special										
Bearing/ Gear material	E	sintered bearing / plastics gear wheels										
Shaft end	N	standard shaft ∅ 4 with flat										

All specifications are representative only and maybe subject to variation. For confirmation of values, please contact Johnson Electric.  
Please also read "Saia Motors Important Notes" on catalog or at [www.johnsonelectric.com/SaiaMotorsNotes](http://www.johnsonelectric.com/SaiaMotorsNotes)



## Technical Data

Technical data of bare gearbox. Data of complete gearmotors on request

Stages	1	2	3	4
Ratios *	4,4	19,2	85	370
Max.torque **	10	20	30	30
Short peak torque **	15	30	45	45
Gear efficiency **	0,85	0,75	0,65	0,55

\* Approximate values, precise values on request.

Other ratios between 3,8 ...850 on request.

\*\* Approximate values, must be tested under specific operating conditions in application.  
Higher values on request.

### Dimensions

Example motor combination: with DC motor NF213G; standard shaft

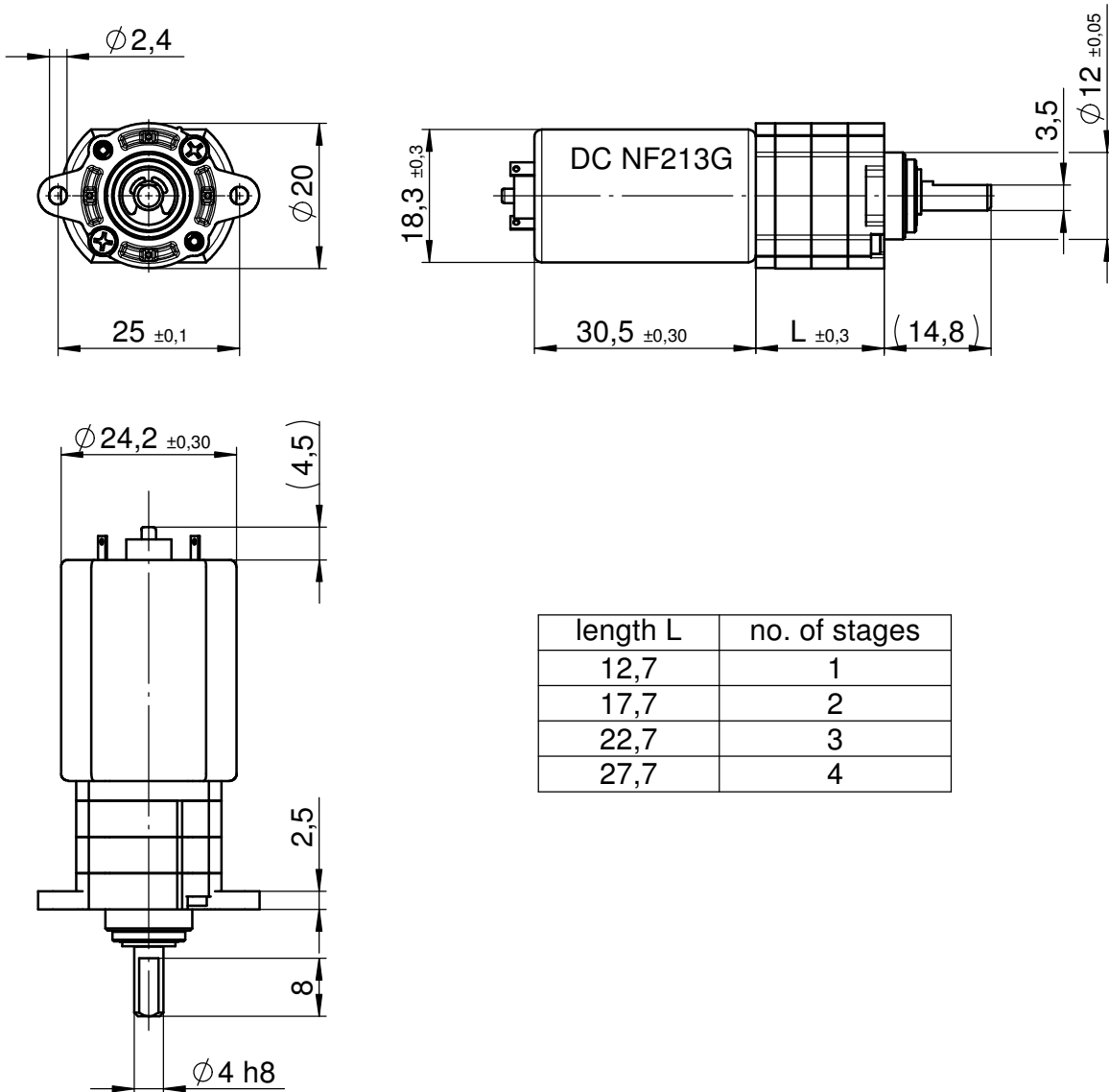

length L	no. of stages
12,7	1
17,7	2
22,7	3
27,7	4

## UGD

Dimensions (mm)	55 x 65.6
Height (mm)	13
Max. torque (cNm)	32
Ratios	4 1/6 ... 6.048.000
Internal slipping clutch	optional for ratios $\geq 33\frac{1}{3}$
Standard shaft (mm)	$\varnothing 4 \times 10$
Weight (g)	35
Motor combination	Series UC, UB and UD; Series UF without UFR3/4 and UFB3/4



## Standard Data

Mounting	any position
Axial thrust $F_A$	10 N
Lateral force $F_R$	50 N
Slipping clutches/free wheel	single-way clockwise/counter clockwise function and two way
Slipping-/free wheel torque	1 ... 40 cNm
Output shafts	$\varnothing 4 \times 10$ , other on request
Climatic class	wide-spread according to DIN IEC 60721-2-1
Ambient temperature operation	$^{\circ}\text{C} -15 \dots +55$
Ambient temperature storage	$^{\circ}\text{C} -40 \dots +80$

Ratios	4 1/6	5	8 1/3	10	12 1/2	15	16 2/3	20 5/6	25	30	33 1/3	40	41 2/3
	45	50	60	62 1/2	83 1/3	100	120	125	150	166 2/3	200	250	300
	375	500	600	625	750	900	1000	1200	1500	1800	2000	2400	2500
	3000	3600	3750	4500	5000	6000	7500	9000	10000	15000	18000	21600	22500
	30000	36000	45000	54000	60000	72000	90000	108000	112500	120000	180000	216000	225000
	270000	300000	360000	432000	450000	720000	864000	1800000	5040000	6048000			

## Order Reference

Type	Gearbox	UGD	100	N	5cNm	N
Ratio	100					
Slipping clutch	N Without slipping clutch ER One-way slipping clutch, clockwise EL One-way slipping clutch, counter clockwise Z Two-way slipping clutch					
Slipping torque	5 cNm (for instance)					
Shaft end	N $\varnothing 4 \times 10$ , other on request					

All specifications are representative only and maybe subject to variation. For confirmation of values, please contact Johnson Electric. Please also read "Saia Motors Important Notes" on catalog or at [www.johnsonelectric.com/SaiaMotorsNotes](http://www.johnsonelectric.com/SaiaMotorsNotes)

Dimensions

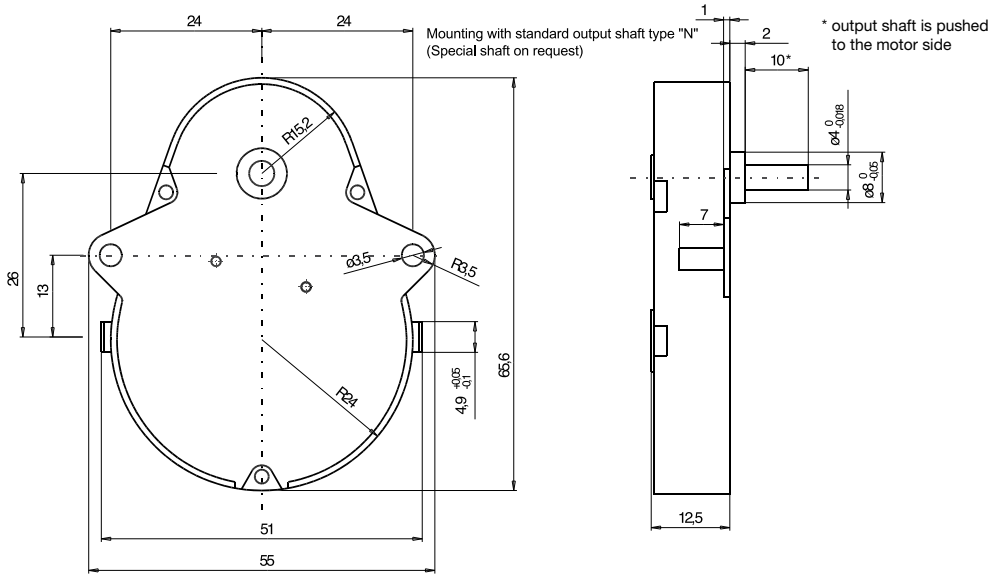

UDS 1..D

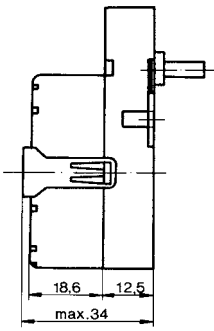

UBR 1/UBR 2..D

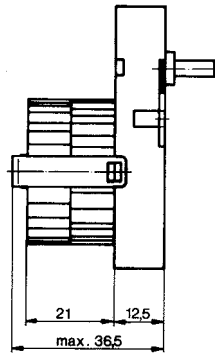

UDR 1..D

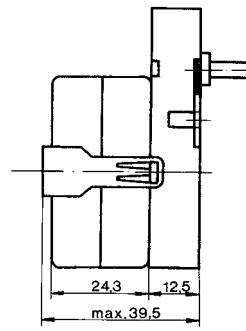

UFM 1/UFU 1/UFR 1..D

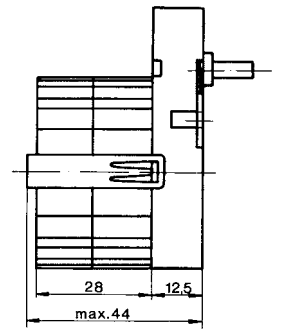

## Slipping clutches

	max. torque available at output shaft (cNm)	free wheel-/clutch torque (cNm)
Roller-type free wheel	32	1
Single-way slipping clutches	32	4 ... 25 counter clockwise or clockwise function
Two-way slipping clutches	3 ... 15	4 ... 40

## Torque / ratio / life graph

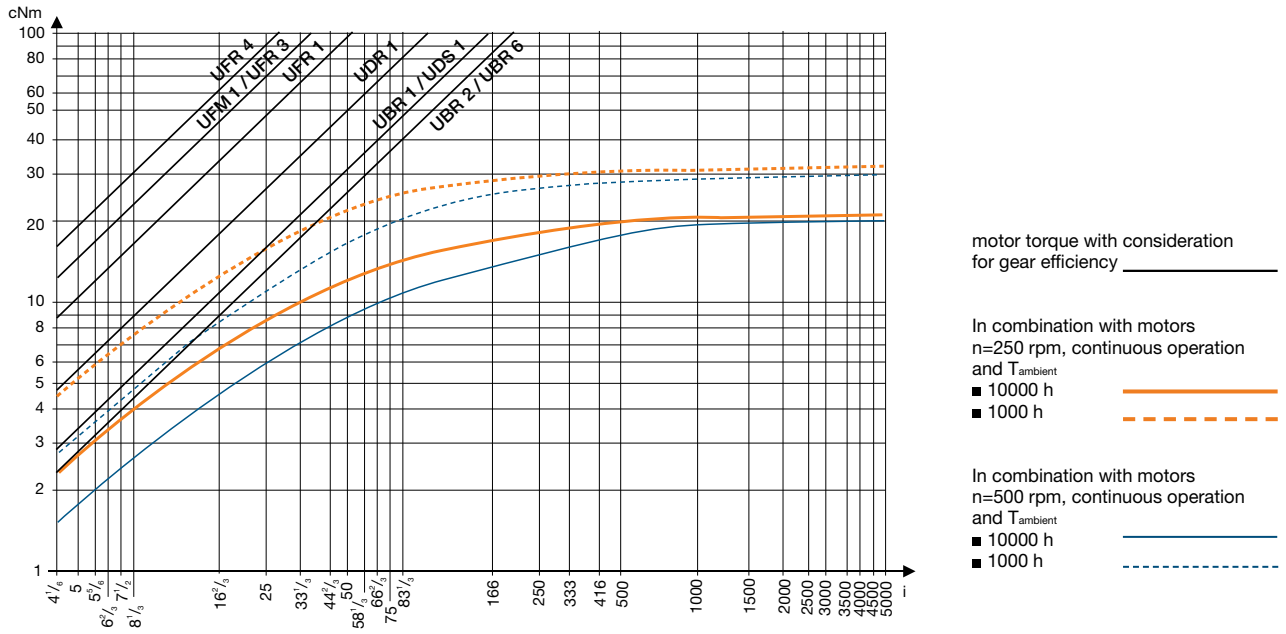

## UGM

Dimensions (mm)	51 x 65.2
Height (mm)	15
Max. torque (cNm)	100
Ratios	12.5 ... 4800
Internal slipping clutch	none
Standard shaft (mm)	∅ 4 x 10
Weight (g)	45
Motor combination	Series UC, UB and UD; Series UF without UFR3/4 and UFB3/4



## Standard Data

Mounting	any position
Axial thrust $F_A$	20 N
Lateral force $F_R$	100 N
Output shafts	∅ 4 x 10, other on request
Climatic class	wide-spread according to DIN IEC 60721-2-1
Ambient temperature operation	°C -15 ... +60
Ambient temperature storage	°C -40 ... +80

Ratios	12 1/2	16 2/3	25	50	100	120	150	200	240	300	400	450	500	600
	750	1000	1200	1500	4800									

## Order Reference

Type	Gearbox	UGM	100	N	N
Ratio	100				
Slipping clutch	N Without slipping clutch				
Shaft end	N ∅ 4 x 10, other on request				

Dimensions

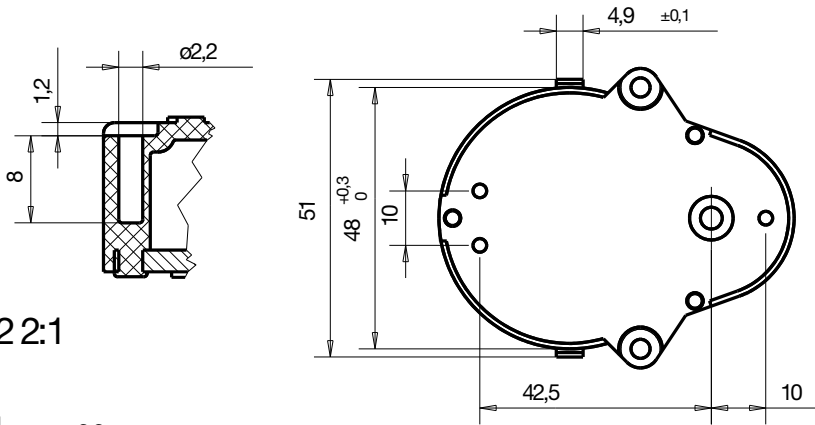

E22:1

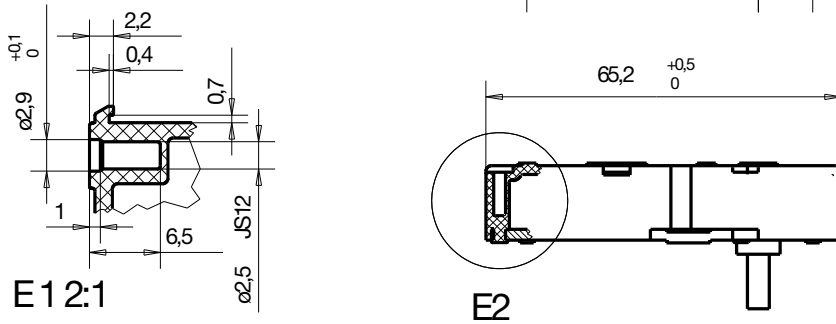

E12:1

E2

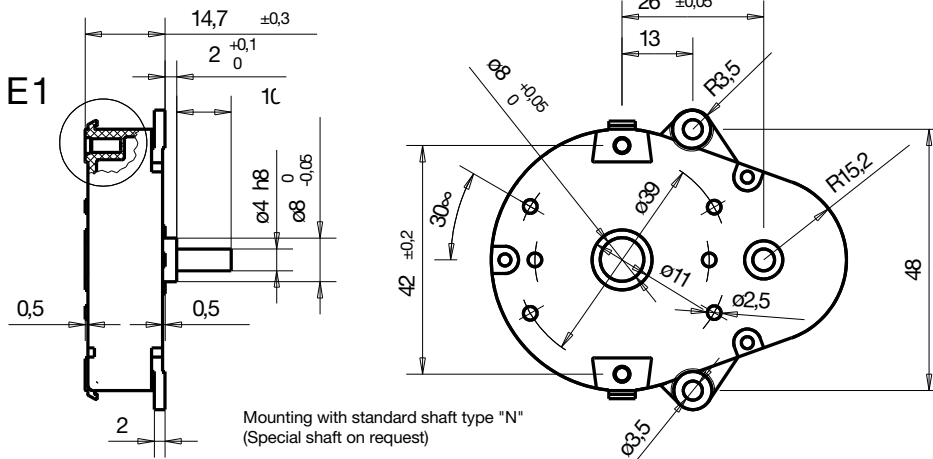

E1

UDS 1..M

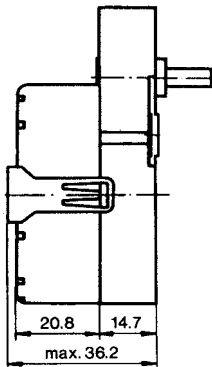

UBR 1..M

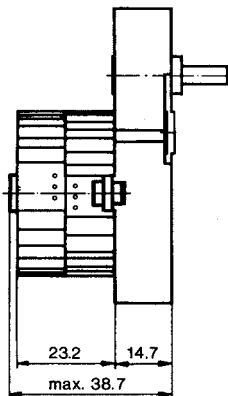

UDR 1..M

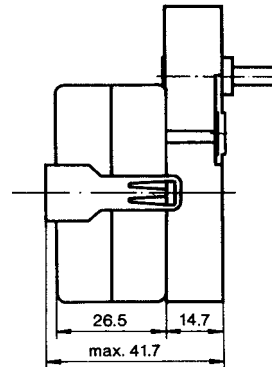

UFM 1/UFU 1/UFR 1..M

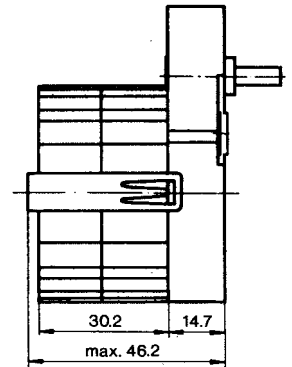

Dimensions UC ...M

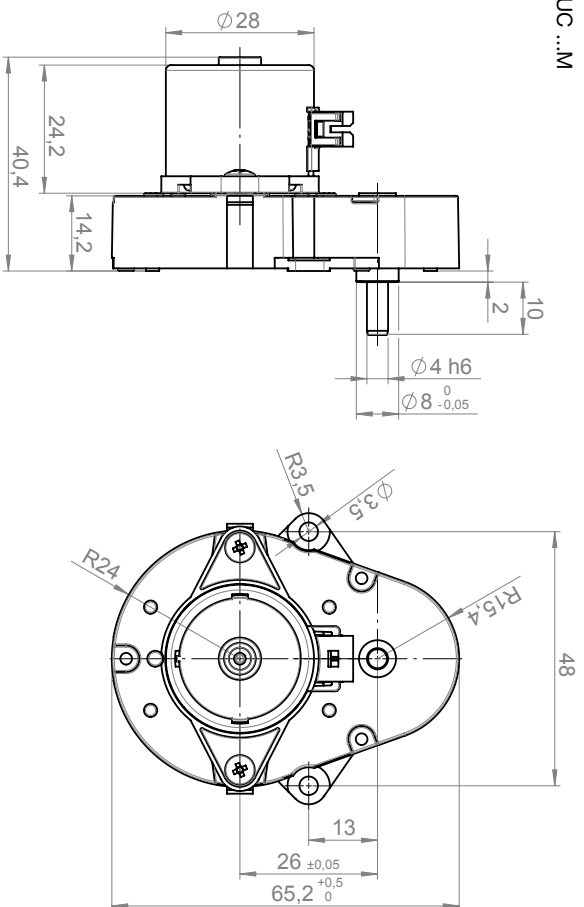

Motor mounting

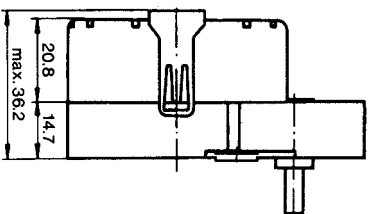

UBR 1..M

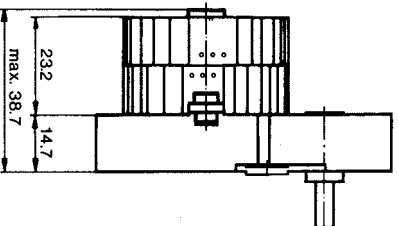

UDR 1..M

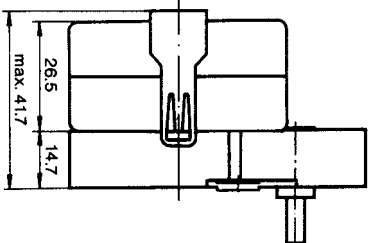

UFM 1/UFU 1/UFR 1..M

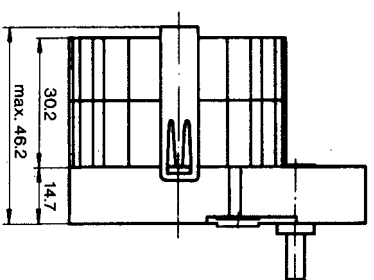

### Torque / ratio / life graph

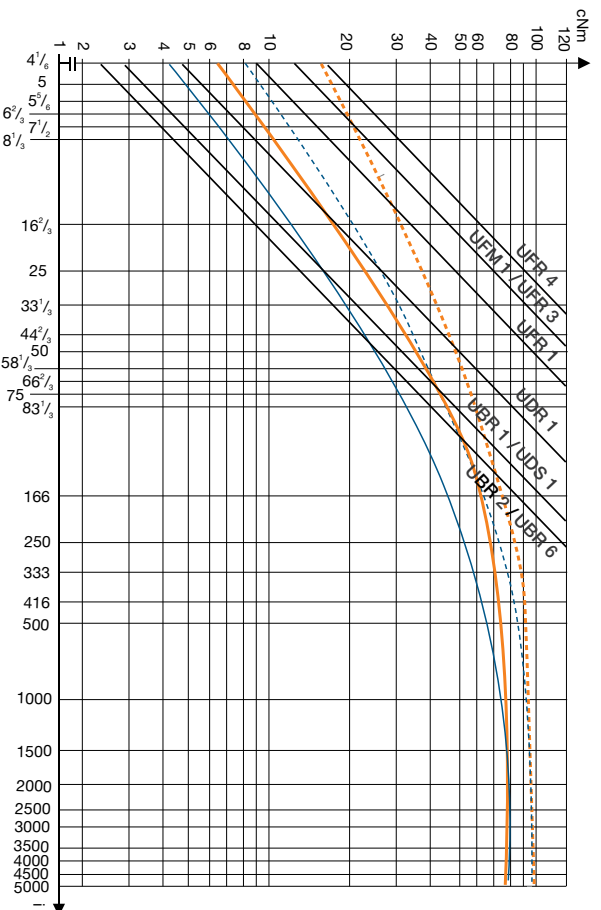

motor torque with consideration for gear efficiency

In combination with motors  
n=250 rpm, continuous operation  
and  $T_{ambient}$   
■ 10000 h  
■ 1000 h

In combination with motors  
n=500 rpm, continuous operation  
and  $T_{ambient}$   
■ 10000 h  
■ 1000 h

## UGB

Dimensions (mm)	58 x 81
Height (mm)	17
Max. torque (cNm)	250
Ratios	41 <sup>2/3</sup> ... 345.600
Internal slipping clutch	optional
Standard shaft (mm)	Ø 8 x 12
Weight (g)	130
Motor combination	Series UC, UB and UD; Series UF without UFR3/4 and UFB3/4



## Standard Data

Mounting	any position
Axial thrust F <sub>A</sub>	100 N
Lateral force F <sub>R</sub>	300 N
Slipping clutches/free wheel	single-way clockwise/counter clockwise function and two way
Slipping-/free wheel torque	4 ... 175 cNm
Output shafts	Ø 8 x 12, other on request
Climatic class	wide-spread according to DIN IEC 60721-2-1
Ambient temperature operation	°C -15 ... +55
Ambient temperature storage	°C -40 ... +80

Ratios	41 <sup>2/3</sup>	83 <sup>1/3</sup>	100	125	150	166 <sup>2/3</sup>	200	250	300	500	600	750	900
	1000	1200	1500	1800	2000	2500	3000	3750	5000	6000	7500	12000	15000
	18000	30000	36000	60000	120000	266666 <sup>2/3</sup>	288000	320000	345600				

## Order Reference

Type	Gearbox	UGB	100	N	5cNm	N
Ratio	100					
Slipping clutch	N Without slipping clutch ER One-way slipping clutch, clockwise EL One-way slipping clutch, counter clockwise Z Two-way slipping clutch					
Slipping torque	5 cNm					
Shaft end	N Ø 8 x 12, other on request					

All specifications are representative only and maybe subject to variation. For confirmation of values, please contact Johnson Electric.  
Please also read "Saia Motors Important Notes" on catalog or at [www.johnsonelectric.com/SaiaMotorsNotes](http://www.johnsonelectric.com/SaiaMotorsNotes)



Dimensions

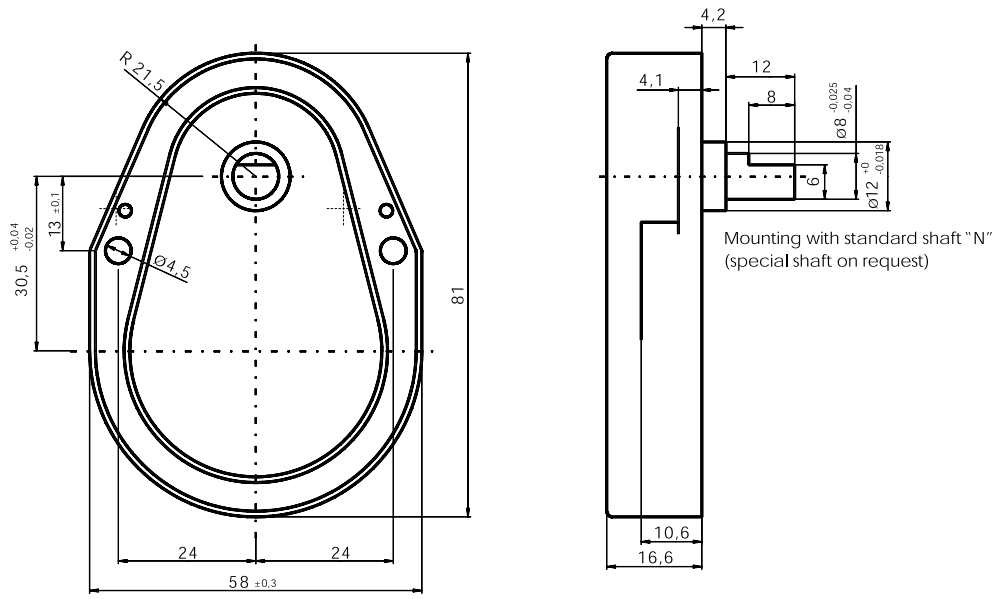

UDS 1..B

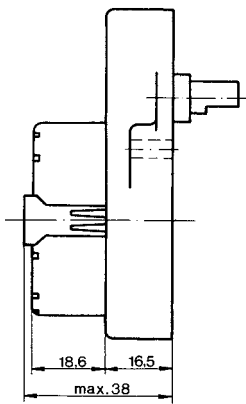

UBR 1/UBR 2..B

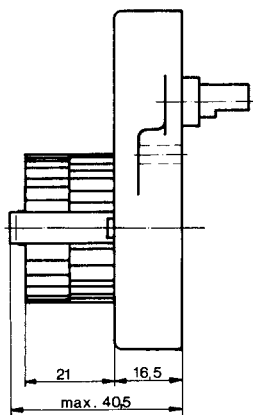

UDR 1..B

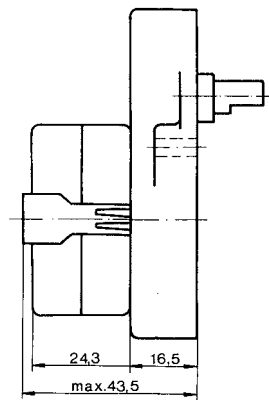

UFM 1/UFU 1/UFR 1..B

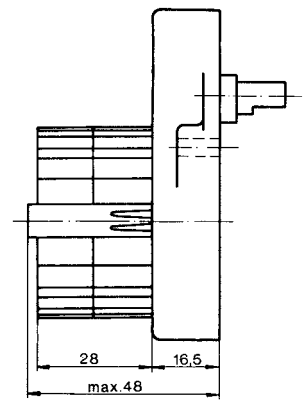

## Slipping clutches

	max. torque available at output shaft (cNm)	free wheel-/clutch torque (cNm)
Roller-type free wheel		
Single-way slipping clutches	150	4 ... 50 counter clockwise or clockwise direction possible
Two-way slipping clutches	40 ... 70	60 ... 175

## Torque / ratio / life graph

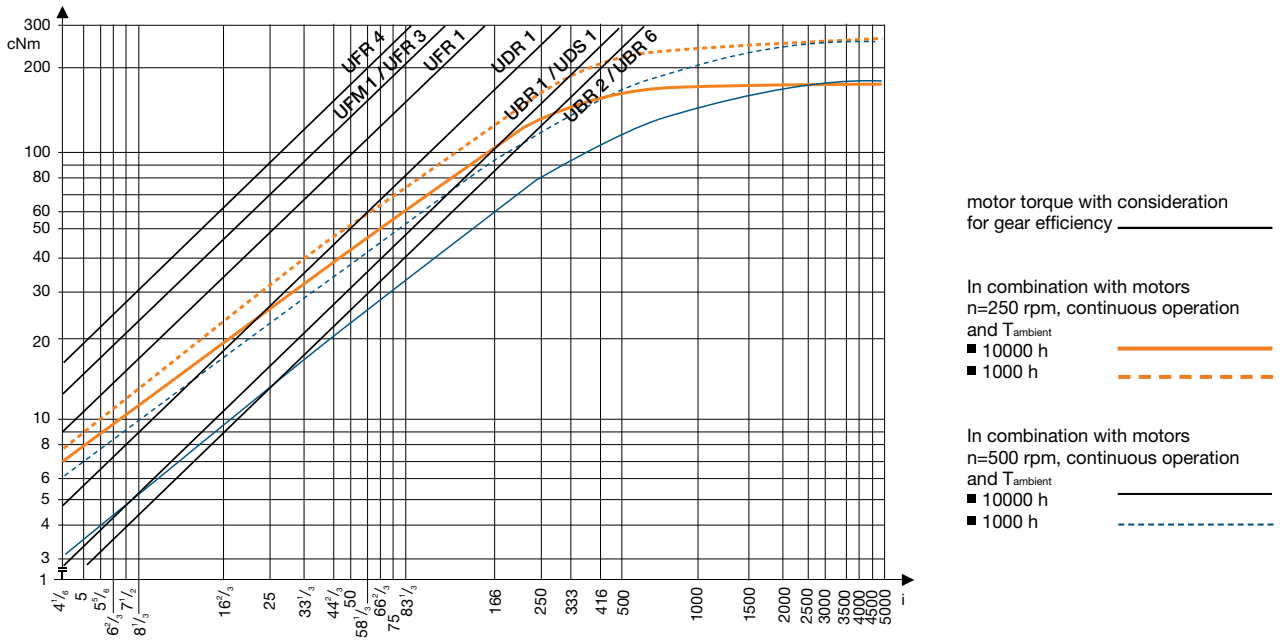

## UGF

Dimensions (mm)	58 x 81
Height (mm)	17
Max. torque (cNm)	500
Ratios	4 <sup>1/6</sup> ... 5000
Internal slipping clutch	none
Standard shaft (mm)	∅ 8 x 12
Weight (g)	130
Motor combination	Series UC, UB, UD, UF



## Standard Data

Mounting	any position
Axial thrust $F_A$	100 N
Lateral force $F_R$	400 N
Slipping clutches/free wheel	none
Slipping-/free wheel torque	cNm
Output shafts	∅ 8 x 12, other on request
Climatic class	wide-spread according to DIN IEC 60721-2-1
Ambient temperature operation	°C -15 ... +55
Ambient temperature storage	°C -40 ... +80

Ratios	4 <sup>1/6</sup>	8 <sup>1/3</sup>	16 <sup>2/3</sup>	20 <sup>5/6</sup>	25	30	41 <sup>2/3</sup>	50	62 <sup>1/2</sup>	83 <sup>1/3</sup>	100	125	166 <sup>2/3</sup>
	250	333 <sup>1/3</sup>	500	600	750	1000	1200	1500	4000	5000			

## Order Reference

Type	Gearbox	UGF	100	N	N
Ratio	100				
Slipping clutch	N Without slipping clutch				
Shaft end	N ∅ 8 x 12, other on request				

All specifications are representative only and maybe subject to variation. For confirmation of values, please contact Johnson Electric. Please also read "Saia Motors Important Notes" on catalog or at [www.johnsonelectric.com/SaiaMotorsNotes](http://www.johnsonelectric.com/SaiaMotorsNotes)

## Dimensions

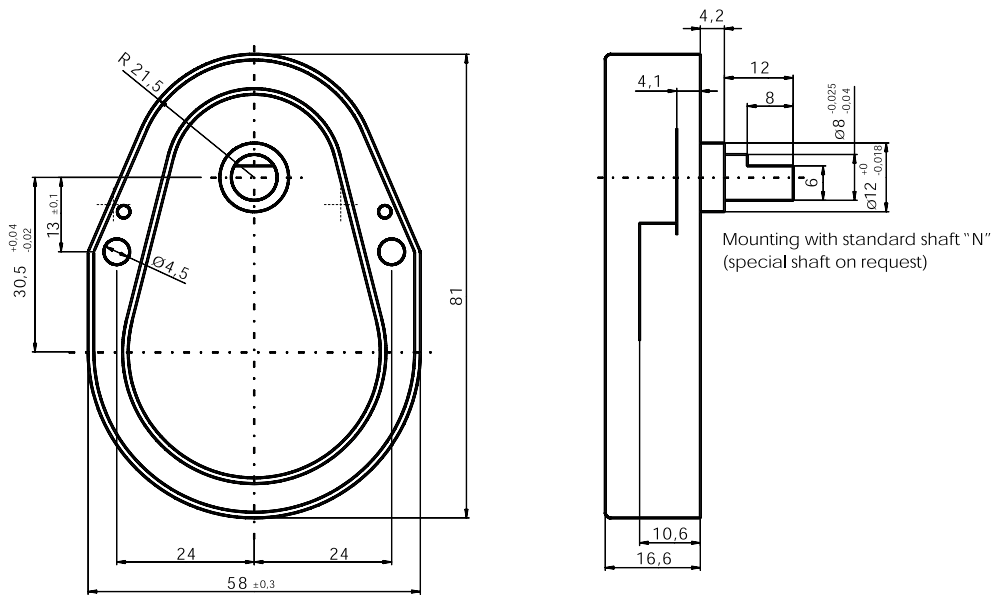

UDS 1..F

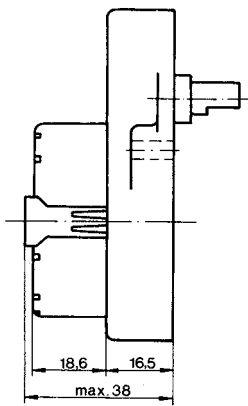

UBR 1/UBR 2..F

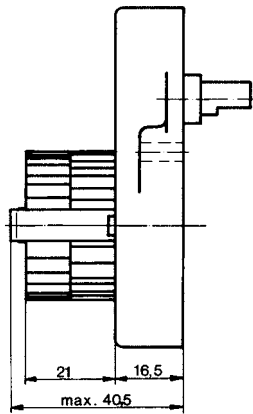

UDR 1..F

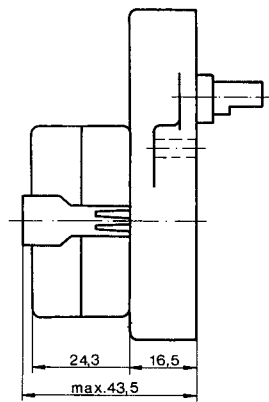

UFM 1/UFU 1/UFR 1..F

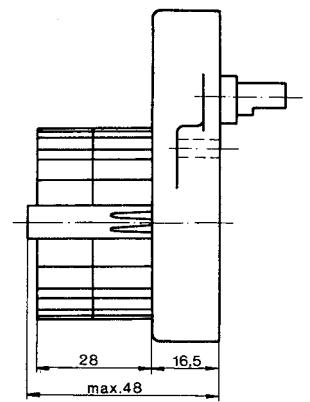

UFR 3..F

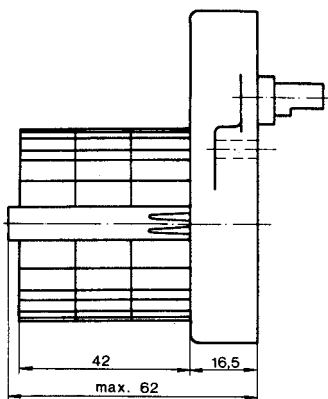

UFR 4..F

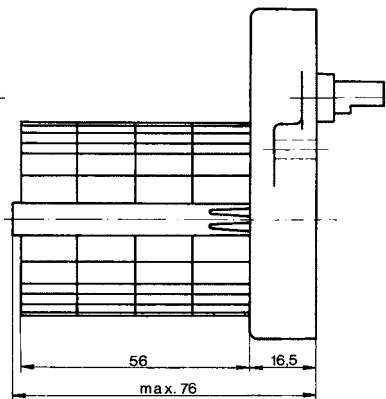

## Torque / ratio / life graph

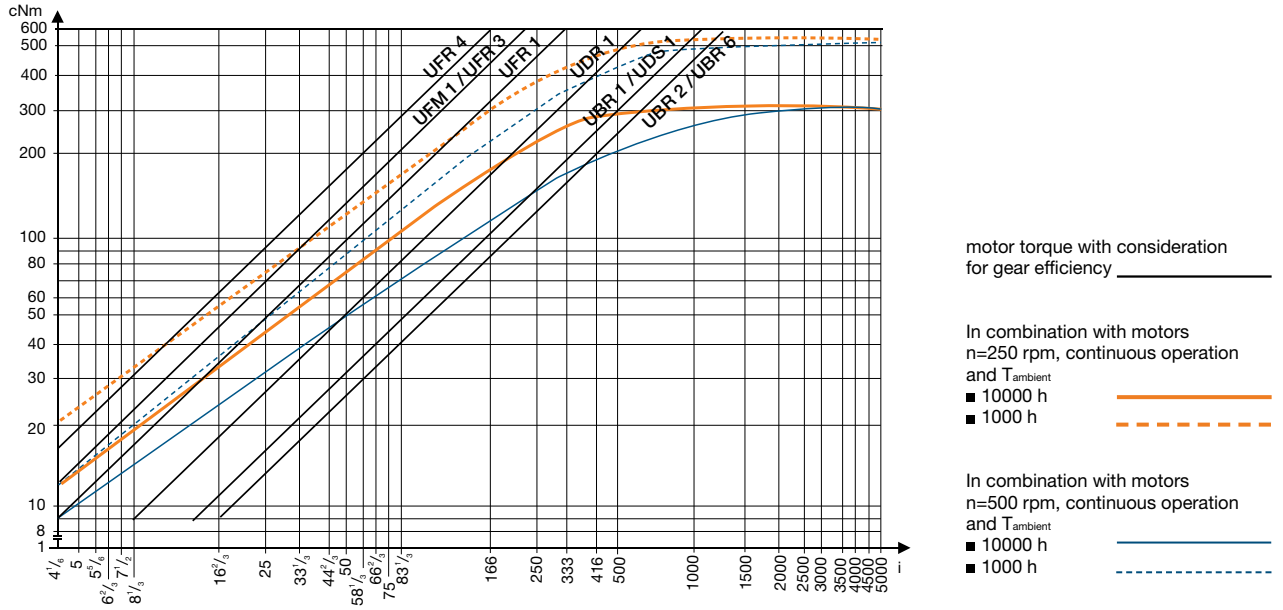

## UGV

Dimensions (mm)	70 x 70
Height (mm)	17
Max. torque (cNm)	500
Ratios	8 <sup>1/3</sup> ... 2000
Internal slipping clutch	none
Standard shaft (mm)	Ø 8 x 12
Weight (g)	130
Motor combination	Series UB, UD, UF



## Standard Data

Mounting	any position
Axial thrust F <sub>A</sub>	100 N
Lateral force F <sub>R</sub>	400 N
Output shafts	Ø 8 x 12, other on request
Climatic class	wide-spread according to DIN IEC 60721-2-1
Ambient temperature operation	°C -15 ... +55
Ambient temperature storage	°C -40 ... +80

Ratios 8<sup>1/3</sup>    16<sup>2/3</sup>    25    41<sup>2/3</sup>    83<sup>1/3</sup>    100    125    250    500    2000

## Order Reference

Type	Gearbox	UGV	100	N	N
Ratio	100				
Slipping clutch	N Without slipping clutch				
Shaft end	N Ø 8 x 12, other on request				

*All specifications are representative only and maybe subject to variation. For confirmation of values, please contact Johnson Electric. Please also read "Saia Motors Important Notes" on catalog or at [www.johnsonelectric.com/SaiaMotorsNotes](http://www.johnsonelectric.com/SaiaMotorsNotes)*

Dimensions

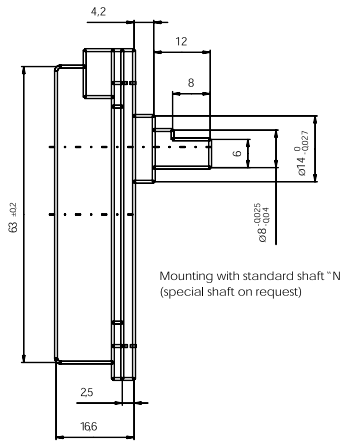
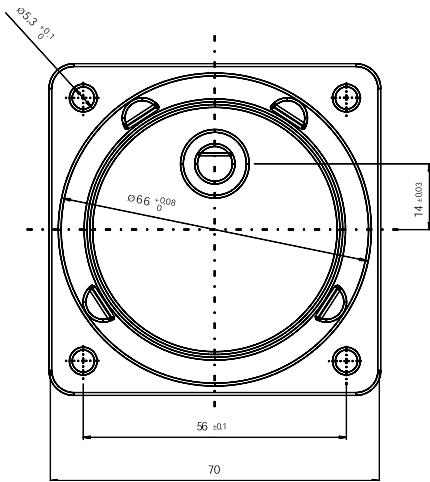

UDS 1..V

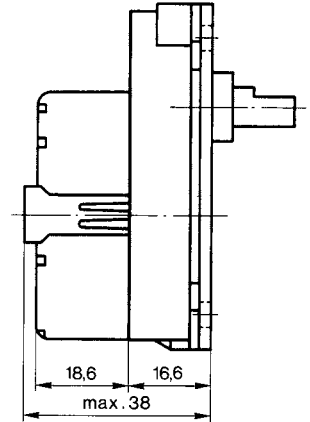

UBR 1/UBR 2..V

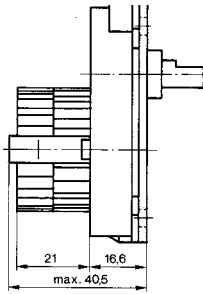

UDR 1..V

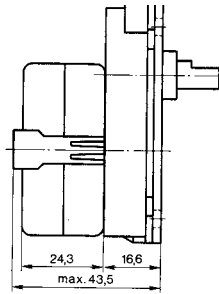

UFM 1/UFU1/UFR 1..V

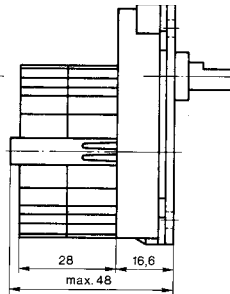

UFR 3..V

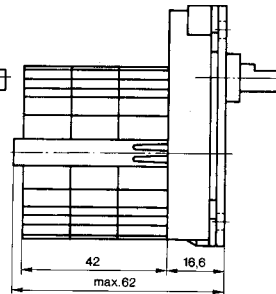

UFR 4..V

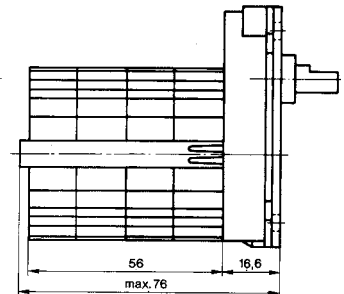

## Torque / ratio / life graph

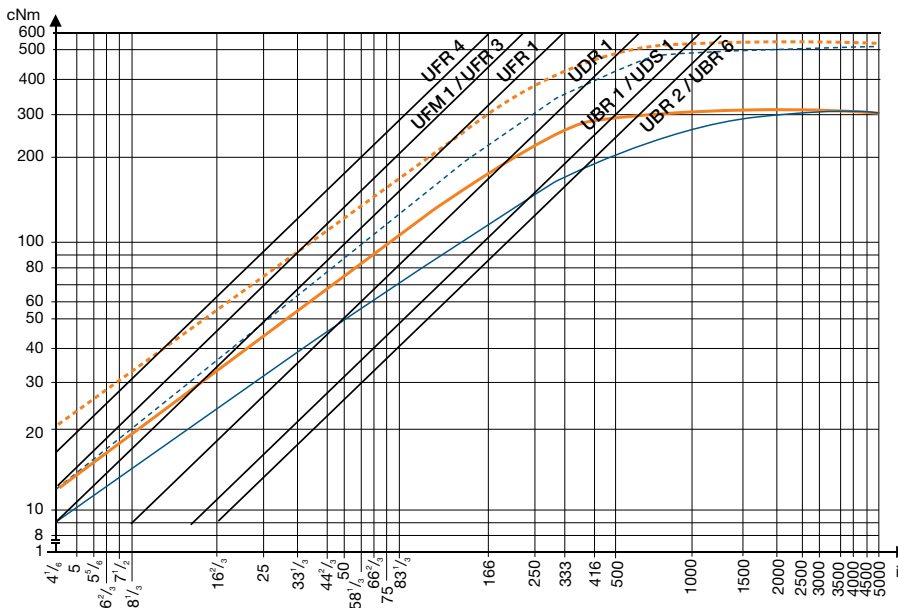

motor torque with consideration for gear efficiency \_\_\_\_\_

In combination with motors  
n=250 rpm, continuous operation  
and T<sub>ambient</sub>

■ 10000 h ————  
■ 1000 h - - - - -

In combination with motors  
n=500 rpm, continuous operation  
and T<sub>ambient</sub>

■ 10000 h ————  
■ 1000 h - - - - -

# UGO/UGP

## UGO/UGP (STG60/61)

Dimensions (mm)	65 x 65/68 x 68
Height (mm)	29.8–38
Max. torque (cNm)	600
Ratios	6 1/4 ... 3750
Internal slipping clutch	none
Standard shaft (mm)	∅ 8 x 22
Weight (g)	230–330
Motor combination	series UF and UP



UGO (STG 60)



UGP (STG 61)

## Standard Data

Mounting	any position
Max. input speed*	3000 min <sup>-1</sup>
Max. output torque*	600 cNm
Max. input -and output power	please refer to table in Technical Data
Average back lash	unloaded 1.5 degree
	2–4 stages with 6 Nm 3 degree
	5–6 stages with 6 Nm 4 degree
Max. axial force F <sub>A</sub>	30 N
Max. lateral force F <sub>R</sub> , 12 mm from flange	80 N
Max. axial play	0.3 mm
Max. radial play	20 μm
Ambient temperature operation	–15 ... +60°C
Ambient temperature storage	–40 ... +100 °C

Ratio	6 1/4	12 1/2	18 3/4	25	31 1/2	37 1/2	46 7/8	50	62 1/2	75
	93 3/4	125	150	187 1/2	250	375	750	1500	2000	3750

\* Depends on ratio, see next page

## Order Reference

Type	Gearbox			STG60 UGO	6 1/4	M	N
Ratio	6 1/4						
Mounting layouts (fixing)	K	UGO					
	M	UGP	through holes				
	R	M4	threads on gearbox flange side				
	T	M4	threads on motor side				
	V	M4	threads on both sides				
	shaft end N ∅ 8 x 25, other upon request						
optional	motor pinion: see next pages	Motor Pinion Data					
	adaptor plate: see next pages	for adaptor plate					

All specifications are representative only and maybe subject to variation. For confirmation of values, please contact Johnson Electric. Please also read "Saia Motors Important Notes" on catalog or at [www.johnsonelectric.com/SaiaMotorsNotes](http://www.johnsonelectric.com/SaiaMotorsNotes)



## Technical Data

Ratio	Stages *	Efficiency	Pinion type	Weight	Max. torque (Nm)	Max. input speed (rpm)
6 1/4	2	0.77	1	190	1.0	750
12 1/2	3	0.68	2	220	1.8	1500
18 3/4	3	0.68	3	220	2.7	2250
25	3	0.68	3	220	3.6	3000
31 1/4	3	0.68	4	220	4.5	3000
37 1/2	3	0.68	4	220	5.4	3000
46 7/8	4	0.60	3	250	6	3000
50	4	0.60	2	250	6	3000
62 1/2	4	0.60	2	250	6	3000
75	4	0.60	3	250	6	3000
93 3/4	4	0.60	3	250	6	3000
125	4	0.60	2	250	6	3000
150	4	0.60	3	250	6	3000
187 1/2	4	0.60	4	250	6	3000
250	5	0.53	2	280	6	3000
375	5	0.53	3	280	6	3000
750	5	0.53	4	280	6	3000
1500	6	0.46	4	310	6	3000
2000	6	0.46	4	310	6	3000
3750	6	0.46	4	310	6	3000

Additionally to the input speed limit: max. 120 rpm output speed

Technical Data valid for an ambient temperature operation: -15...+60°C

\* Direction of rotation of output- and motor-shaft at  
 2.4 and 6 stages - same  
 3 and 5 stages - opposite

## Dimensions UGO

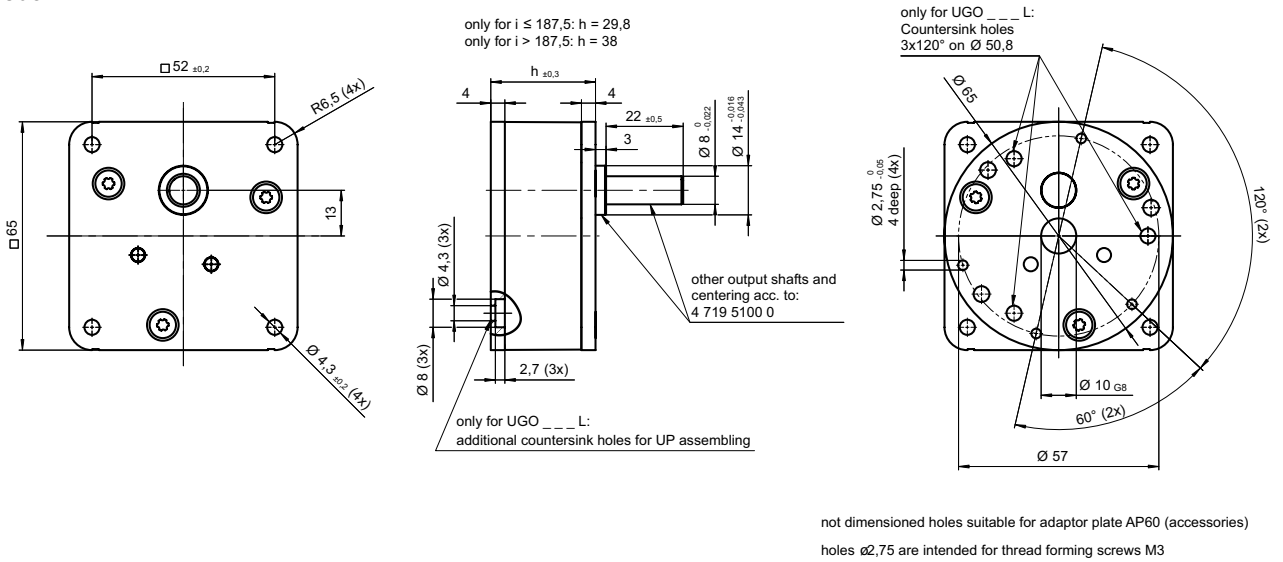

## UGP

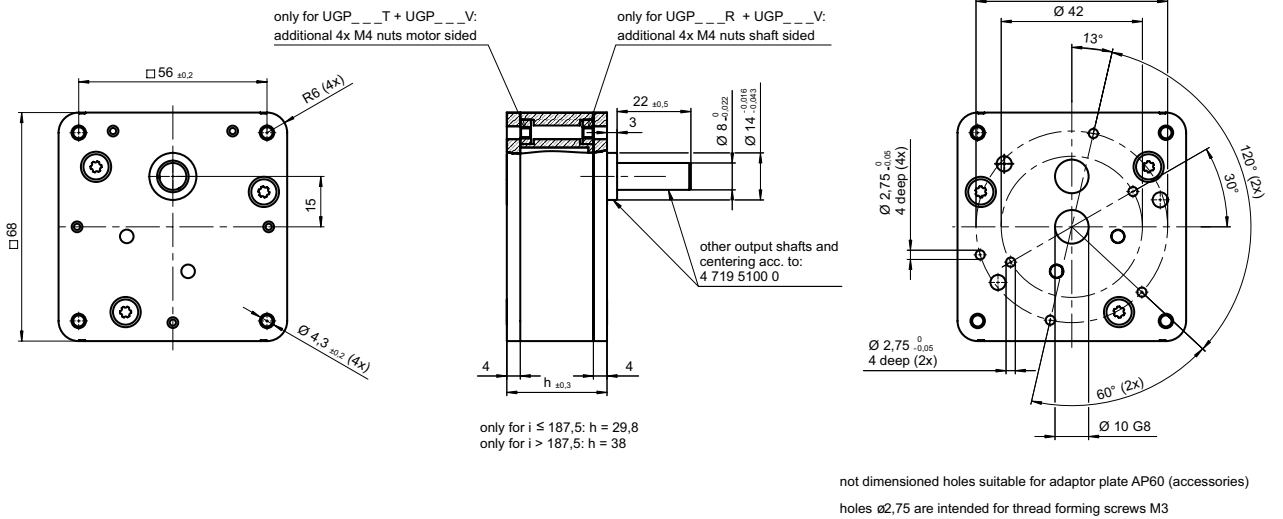

Other shafts on request

## Motor Pinion Data UGO/P (STG 60/61)

pinion type	pinion length b	motor pinion with hole d: 022 100 004 ...			
		Ø2.5S7	Ø3S7	Ø4X7	Ø5S7
1	6	-	020	030	040
2	4.5	-	080	090	110
3	4.5	270	280	290	310
4	4.5	580	590	600	610

Dimensions for motor assembly

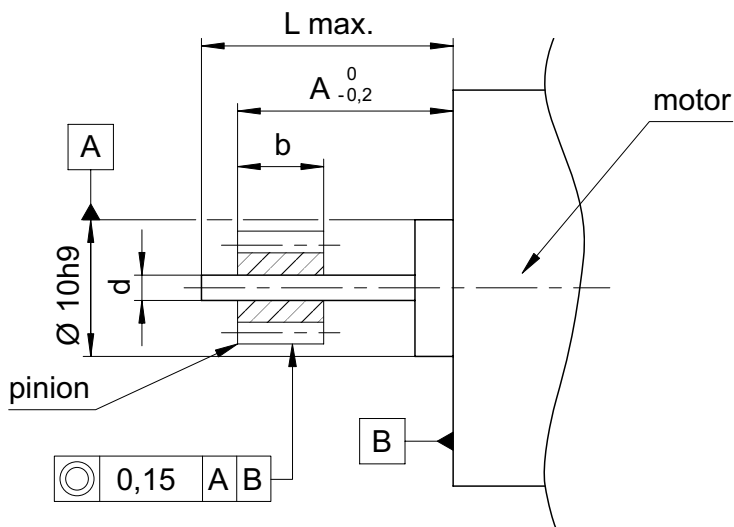

Pinion position	Dimension	A	L
2 gear stages		8,9	9,6
3-6 gear stages		7,6	7,6

# AP 60

## AP 60

Dimensions (mm)  $\varnothing 64$

Height (mm) 6

### Adaptor Plate Data AP 60

Adaptor plate	Motor type	Manufacturer	Centring $\varnothing D$	Order reference
AP 6012	G 30	Dunker	12	81B-001-002-010
AP 6022	G 42, GR 42		22	81B-001-002-016
AP 6014	M 28, M 32	GEFEG	14	81B-001-002-012
AP 6022	M 42, M 48		22	81B-001-002-016

Dimensions

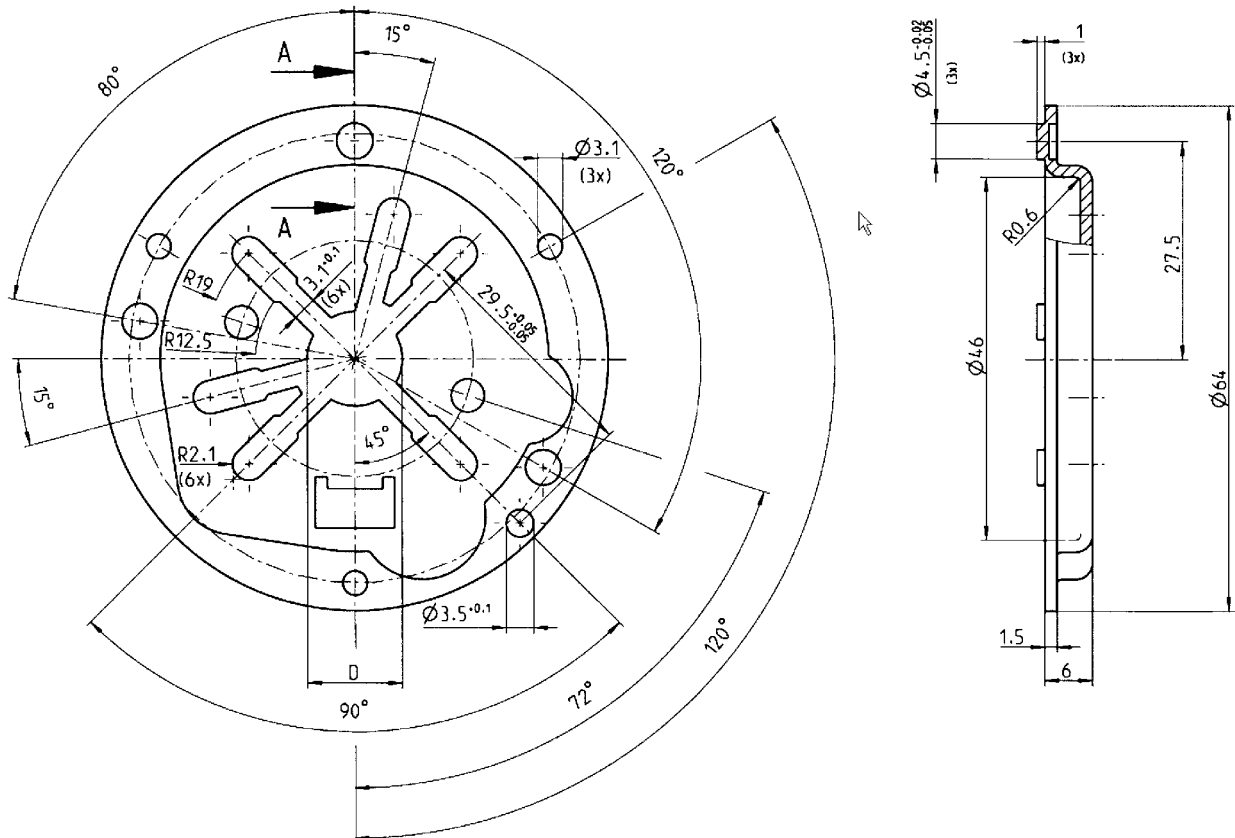

## UGJ

Dimensions (mm)	65 x 107
Height (mm)	28
Max. torque (cNm)	1500
Ratios	4 <sup>1/6</sup> ... 36.000.000
Internal slipping clutch	none
Standard shaft (mm)	∅ 12 x 20
Weight (g)	480
Motor combination	Series UB, UD, UF



## Standard Data

Mounting	any position
Axial thrust F <sub>A</sub>	400 N
Lateral force F <sub>R</sub>	600 N
Output shafts	∅ 12 x 20, other on request
Climatic class	wide-spread according to DIN IEC 60721-2-1
Ambient temperature operation	°C -15 ... +55
Ambient temperature storage	°C -40 ... +80

Ratios*	4 <sup>1/6</sup>	8 <sup>1/3</sup>	16 <sup>2/3</sup>	33 <sup>1/3</sup>	41 <sup>2/3</sup>	50	66 <sup>2/3</sup>	83 <sup>1/3</sup>	100	125	150	166 <sup>2/3</sup>	200
	250	500	1000	2000	2500	3000	4000	5000	6250	8333 <sup>1/3</sup>	10000	12500	15000
	20000	25000	30000	37500	60000	75000	120000	150000	300000	375000	750000	1500000	1800000
	2250000	3000000	3600000	4500000	6000000	9000000	11250000	12000000	18000000	36000000			

\* For ratio ≥ 2500 combination with UGD

## Order Reference

Type	Gearbox	UGJ	100	N	N
Ratio	100				
Slipping clutch	N Without slipping clutch				
Shaft end	N ∅ 12 x 20, other on request				

All specifications are representative only and maybe subject to variation. For confirmation of values, please contact Johnson Electric. Please also read "Saia Motors Important Notes" on catalog or at [www.johnsonelectric.com/SaiaMotorsNotes](http://www.johnsonelectric.com/SaiaMotorsNotes)

## Dimensions

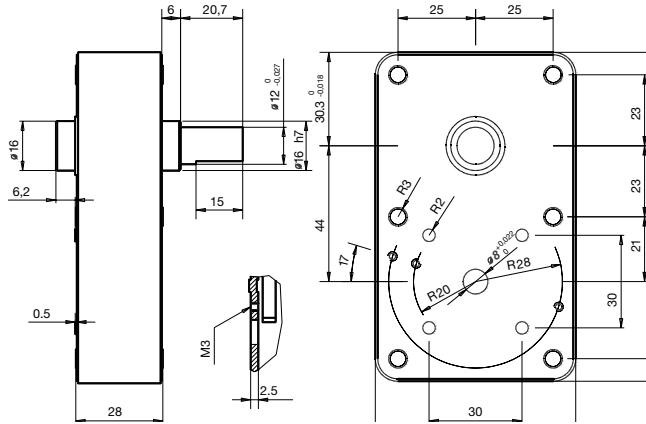

$i \leq 2000$

$i \geq 2500$

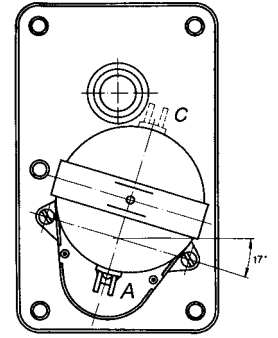
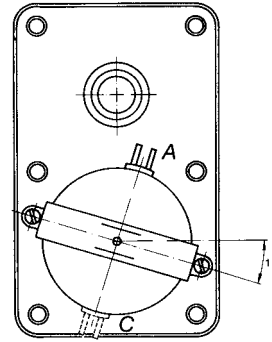

Lead outlet (A = standard position)

UDS 1..J,  $\leq 2000$

UDS 1..J,  $\geq 2500$

UBR 1/UBR 2..J,  $\geq 2500$

UDR 1..J,  $\leq 2000$

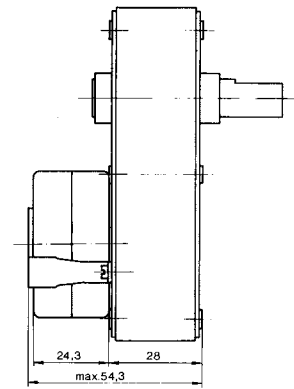
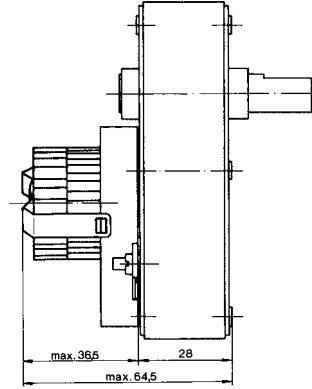
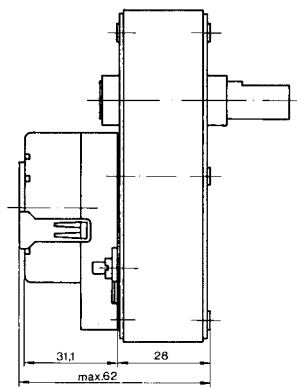
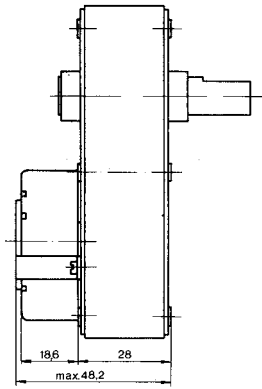

UDR 1..J,  $i \geq 2500$

UFM 1/UFU 1/UFR 1..J,  $i \leq 2000$

UFR 3..J,  $i \leq 2000$

UFR 4..J,  $i \leq 2000$

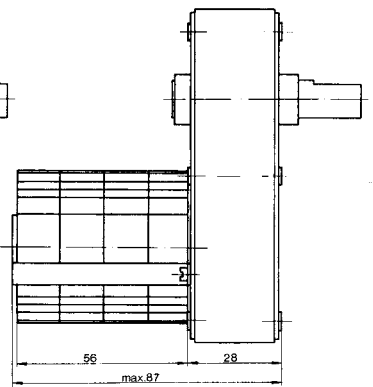
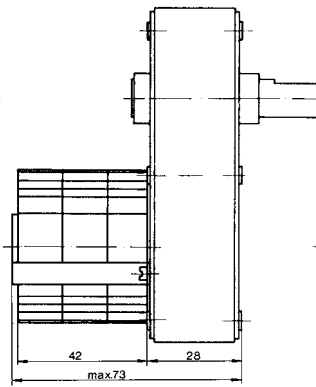
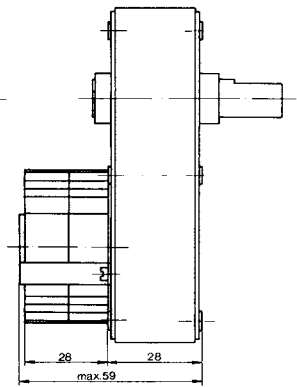
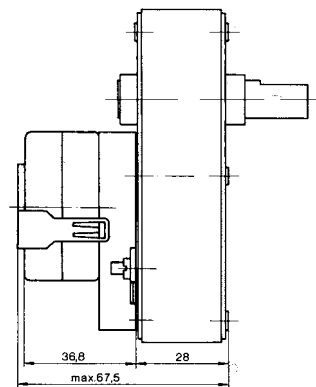

## Torque / ratio / life graph

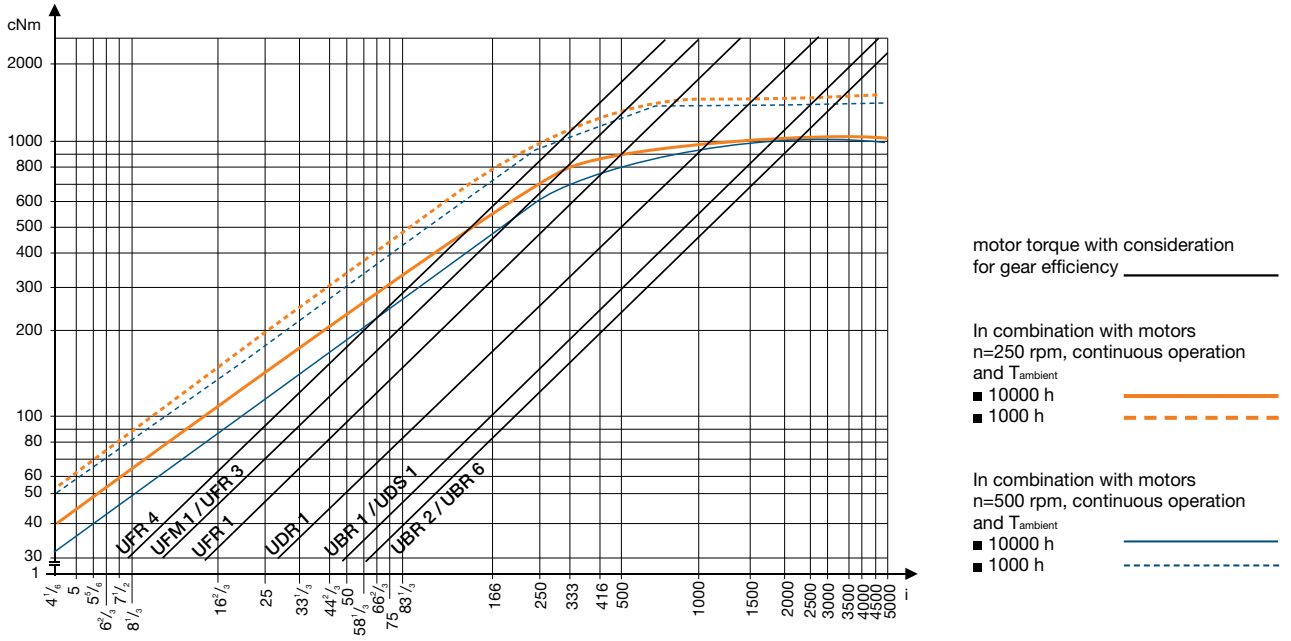

## UGR (STG 200)

Dimensions (mm)	70 x 130
Height (mm)	38
Max. torque (cNm)	2000
Ratios	12.5 ... 375
Internal slipping clutch	none
Standard shaft (mm)	∅ 12 x 35
Weight (g)	depends on ratio
Motor combination	UP



## Standard Data

Mounting	any position
Max. input speed *	3000 min <sup>-1</sup>
Max. output torque *	2000 cNm
Max. input -and output power *	please refer to table in Technical Data
Average back lash unload	0.75°
2/3 stages with 4/10 Nm	1.25°
4/5 stages with 15/20 Nm	2°
Max. axial force F <sub>A</sub>	60 N
Max. lateral force F <sub>R</sub> , 20 mm from flange	80 N
Max. axial play	0.3 mm
Max. radial play	83 μm
Ambient temperature operation	-15 ... +60°C
Ambient temperature storage	-40 ... +100 °C

Ratio	12 1/2	37 1/2	62 1/2	75	93 3/4	125	250	375
-------	--------	--------	--------	----	--------	-----	-----	-----

\* Depends on ratio, see next page

## Order Reference

Type	Gearbox	UGR	12 1/2	N	N
Ratio	12 1/2				
Mounting layouts	N	standard			
Shaft end	N	∅ 12 x 35, others upon request			
optional	motor pinion: see next pages	Motor Pinion Data			

All specifications are representative only and maybe subject to variation. For confirmation of values, please contact Johnson Electric. Please also read "Saia Motors Important Notes" on catalog or at [www.johnsonelectric.com/SaiaMotorsNotes](http://www.johnsonelectric.com/SaiaMotorsNotes)



## Technical Data

Ratio	Stages *	Efficiency	Pinion type	Weight	Max. torque (Nm)	Max. input speed (rpm)
12 1/2	2	0.77	1	560	3.6	1500
37 1/2	3	0.68	2	580	9.9	3000
62 1/2	4	0.60	3	600	14.6	3000
75	4	0.60	4	600	17.5	3000
93 3/4	4	0.60	4	600	20	3000
125	4	0.60	4	600	20	3000
250	5	0.53	5	620	20	3000
375	5	0.53	2	620	20	3000

Additionally to the input speed limit: max. 120 rpm output speed

Technical Data valid for an ambient temperature operation: -15...+60°C

\* Direction of rotation of output- and motor-shaft at  
 2 and 4 stages - same  
 3 and 5 stages - opposite

Dimensions other shafts on request

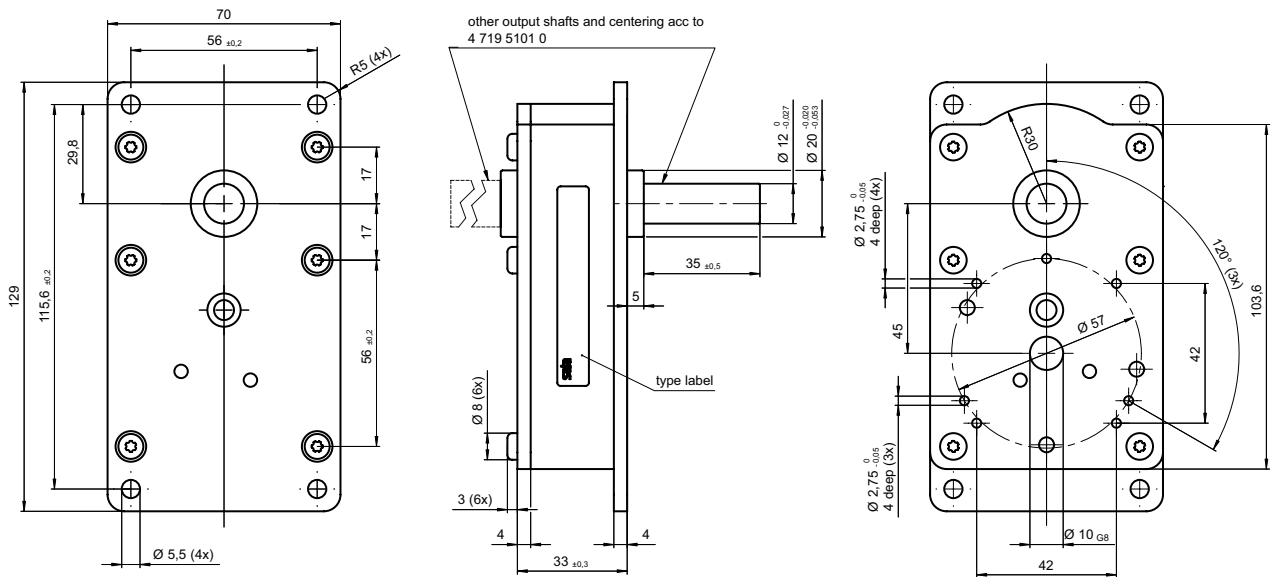

not dimensioned holes suitable for adaptor plate AP60 (accessories)  
 holes 2,75 are intended for thread forming screws M3

## Motor Pinion Data

pinion type	pinion length b	motor pinion with hole d: 022 100 020 ...		
		Ø3S7	Ø4X7	Ø5S7
1	11.5	-	130	140
2	6.8	280	290	300
3	11.5	360	370	380
4	11.5	400	410	-
5	6.8	-	250	260

Dimensions for motor assembly

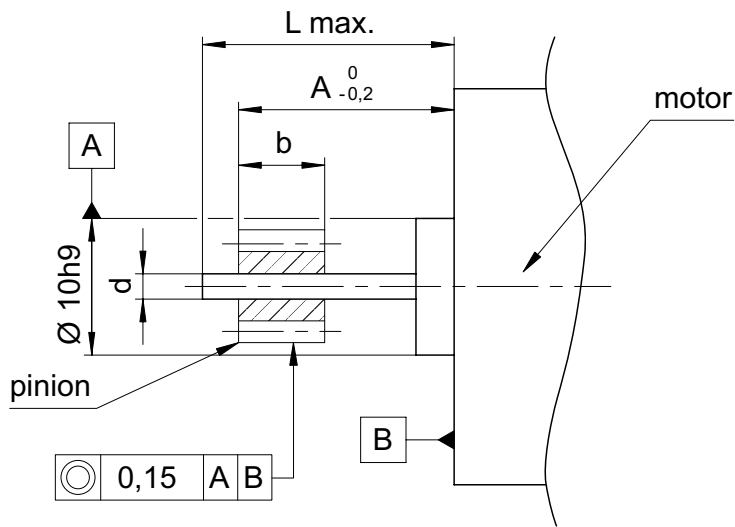

Pinion position	Dimension	A	L
2 gear stages		16.1	28
3 gear stages		10.3	10.3
4 gear stages		15.1	15
5 gear stages		10.9	11

## Planetary Gearbox UGW

Dimensions (mm)	∅ 34 x 62,4 (without motor)
Max. torque (Nm)	4,5 (higher torque on request)
Ratio	541 (4 stages ; other ratios on request)
Standard shaft (mm)	∅ 8 x 21,3 with flat (other dimensions on request)
Motor combinations	Stepper/Synchronous motor UC ; DC motor HC3...6



## Standard Data

Mounting	any position
Axial thrust FA	20 N (depend on lifetime spec ; higher force on request)
Lateral force FR	20 N (depend on lifetime spec ; higher force on request)
Climatic class	wide spread according to DIN IEC 60721-2-1
Ambient temperature operation	°C -20 ... +70
Ambient temperature storage	°C -20 ... +80
Weight	290 g (with DC motor HC313XLG)
Bearing	sintered bronze, self-lubricating

## Order Reference

Example motor combination: with DC motor HC313XLG

Note: UGW is deliverable only as gearbox motor combination

Motor type	JP	DC Motor (brushed)	JP	3	A	N	X9	W	54C	N	F	N
Motor size	3	diameter 27.5 mm										
Motor version	A	13 V; no-load speed 7400 rpm										
Approval	N	standard										
Voltage	X9	13 Vdc										
Gearbox size	W	planetary gearbox diameter 34 mm										
Gear ratio	54C	541 (4 stages)										
Connection	N	standard										
	A	special										
Bearing/ Gear material	F	sintered bearing / metal gear wheels										
Shaft end	N	standard shaft ∅ 8 x 21.3 with flat										

## Technical Data

Technical data of bare gearbox. Data of complete gearmotors on request

Stages	4
Ratio *	541
Max. torque [Nm] **	4,5
Short peak torque [Nm] **	6
Gear efficiency **	0,6

\* Approximate value, precise values on request.

Other ratios between 3,8 ...541 on request.

\*\* Approximate values, must be tested under specific operating conditions in application.

Higher values on request.

### Dimensions

Example motor combination: with DC motor HC313XLG ; standard shaft

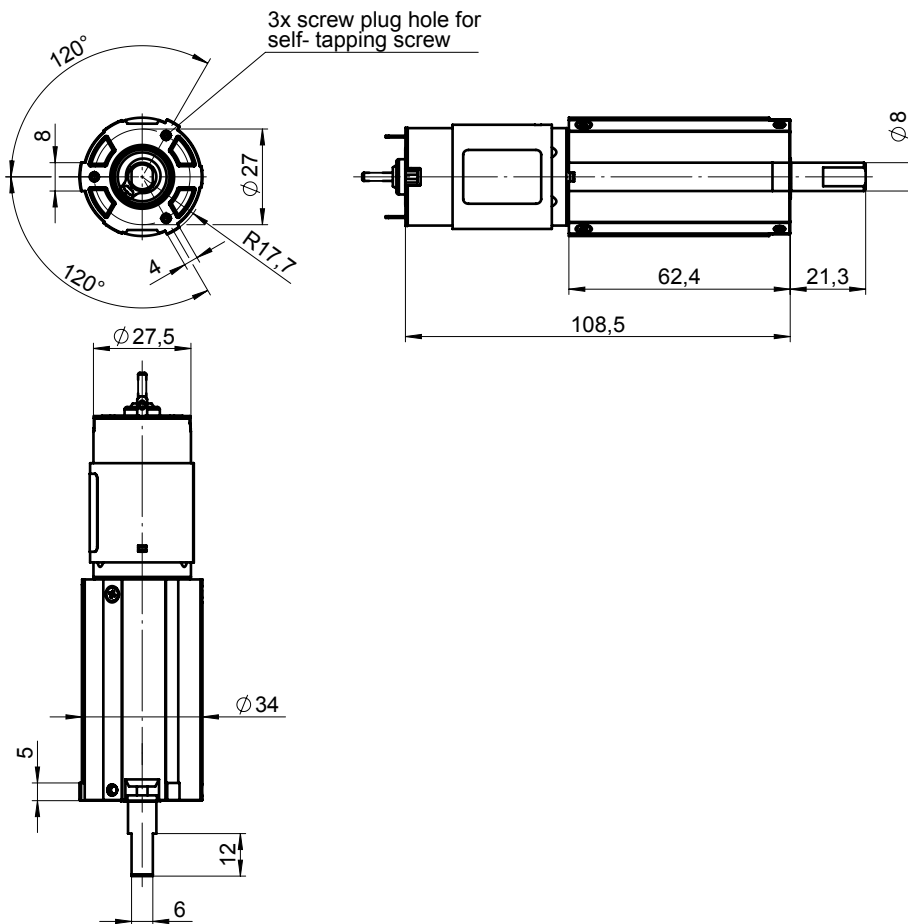

# Gearboxes with DC & BLDC Motors

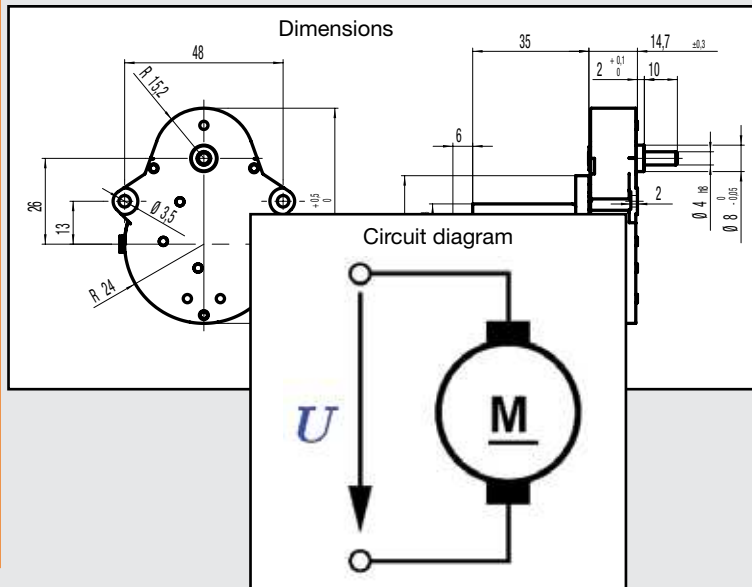

## Gearbox UGM with DC Motor PC280LG



Voltage (Vdc)  
Height (mm) 12/24

Max. torque  
(cNm) 60

### Standard Data

Ambient temperature operation	°C -10 ... +55
Ambient temperature storage	°C -20 ... +80
Rotor stalling	not permissible
Thermal class	130 (B) according to DIN EN 60085 : 2008
Approval	standard
Electrical connection	terminals
Mounting	any position
Weight	105 g
Axial thrust	20 N
Lateral force	100 N
Output shaft	∅ 4 × 10 mm (others on request)
Slipping clutch	no
Bearings	sintered bronze, self-lubricating

### Order Reference

Motor type	JP	DC Motor (brushed)	JP	2	A	N	M4	M	40C	N	N	N
Motor size	2	diameter 24.4 mm										
Motor version	A	12 V; no-load speed 3600 rpm										
	B	24 V; no-load speed 2400 rpm										
Approval	N	standard										
Voltage	M1	12 Vdc										
	M4	24 Vdc										
Gearbox size	M											
Gear ratio	40C	400										
Connection	N	terminals, without lead wire										
	A	with lead wire and connector (on request)										
Slipping clutch	N	without slipping clutch										
Shaft end	N	standard shaft ∅ 4 × 10, others on request										

All specifications are representative only and maybe subject to variation. For confirmation of values, please contact Johnson Electric.  
Please also read "Saia Motors Important Notes" on catalog or at [www.johnsonelectric.com/SaiaMotorsNotes](http://www.johnsonelectric.com/SaiaMotorsNotes)

## Technical Data

### Motor JP2A

Voltage supply	V	12
No-load motor speed	rpm	3600
Rated motor speed	rpm	2900
Rated motor current	mA	105
Rated motor torque	cNm	0.24

Gear ratio		120	150	240	300	400	500	1000	1500
Rated output speed	rpm	24	20	12	10	8	6	3	2
Rated output torque	cNm	18	23	36	45	60	60	60	60

### Motor JP2B

Voltage supply	V	24
No-load motor speed	rpm	2400
Rated motor speed	rpm	1800
Rated motor current	mA	34
Rated motor torque	cNm	0.19

Gear ratio		120	150	240	300	400	500	1000	1500
Rated output speed	rpm	15	12	8	6	4.5	4	2	1.5
Rated output torque	cNm	14	18	28	36	48	59	60	60

All values approximate. Speed tolerance on request.  
 Output torque permissible max. 60cNm.  
 Continuous duty cycle permissible at rated torque.  
 Higher torque at lower duty cycle on request.  
 Lifetime on request.

## Dimensions

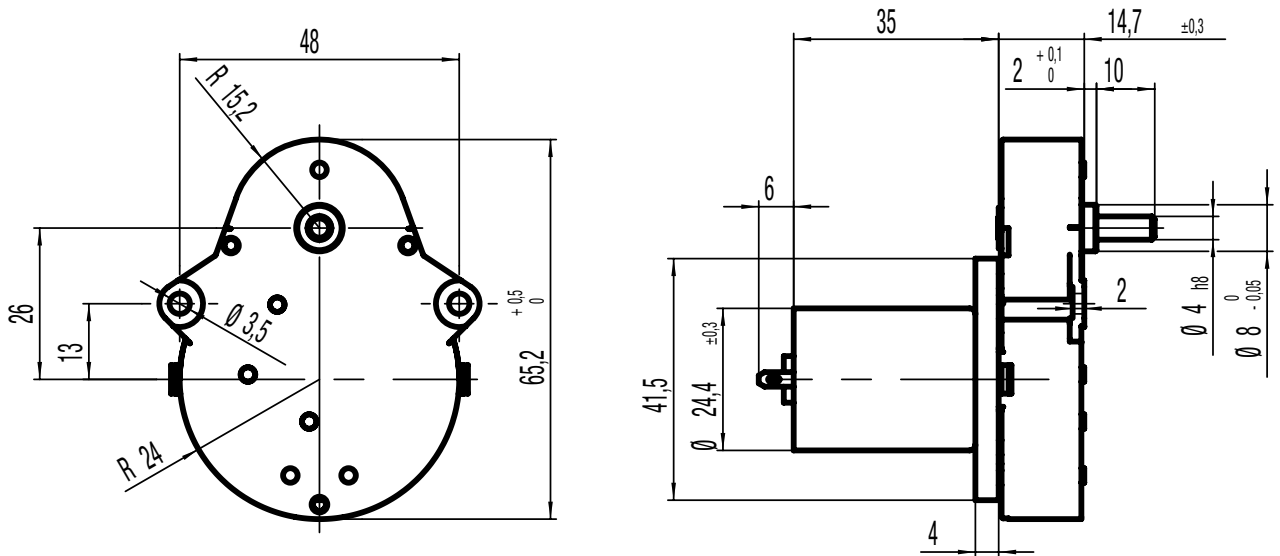

## Gearbox with UGB DC Motor PC280LG

Voltage (Vdc) 12/24

Max. torque (cNm) 200



## Standard Data

Ambient temperature operation	°C -10 ... +55
Ambient temperature storage	°C -20 ... +80
Rotor stalling	not permissible
Approval	standard
Electrical connection	terminals
Mounting	any position
Weight	200 g
Axial thrust	100 N
Lateral force	300 N
Output shaft	∅ 8 × 12 mm (others on request)
Slipping clutch	optional
Bearings	sintered bronze, self-lubricating

## Order Reference

Motor type	JP	DC Motor (brushed)	JP	2	A	N	M4	B	30C	N	N	N
Motor size	2	diameter 24.4 mm										
Motor version	A	12 V; no-load speed 3600 rpm										
	B	24 V; no-load speed 2400 rpm										
Approval	N	standard										
Voltage	M1	12 Vdc										
	M4	24 Vdc										
Gearbox size	B											
Gear ratio	30C	300										
Connection	N	terminals, without lead wire										
	A	with lead wire and connector (on request)										
Slipping clutch	N	without slipping clutch										
Shaft end	N	standard shaft ∅ 8 × 12, others on request										

All specifications are representative only and maybe subject to variation. For confirmation of values, please contact Johnson Electric.  
Please also read "Saia Motors Important Notes" on catalog or at [www.johnsonelectric.com/SaiaMotorsNotes](http://www.johnsonelectric.com/SaiaMotorsNotes)



## Technical Data

### Motor JP2A

Voltage supply	V	12
No-load motor speed	rpm	3600
Rated motor speed	rpm	2900
Rated motor current	mA	105
Rated motor torque	cNm	0.24

Gear ratio		150	200	300	500	600	750	1000	1500
Rated output speed	rpm	20	15	10	6	5	4	3	2
Rated output torque	cNm	23	30	45	75	90	115	150	200

### Motor JP2B

Voltage supply	V	24
No-load motor speed	rpm	2400
Rated motor speed	rpm	1800
Rated motor current	mA	34
Rated motor torque	cNm	0.19

Gear ratio		150	200	300	500	600	750	1000	1500
Rated output speed	rpm	12	9	6	4	3	2.5	2	1.5
Rated output torque	cNm	18	24	36	59	70	90	120	180

All values approximate. Speed tolerance on request.  
 Output torque permissible max. 200cNm.  
 Continuous duty cycle permissible at rated torque.  
 Higher torque at lower duty cycle on request.  
 Lifetime on request.  
 Other gear ratios on request.

### Dimensions

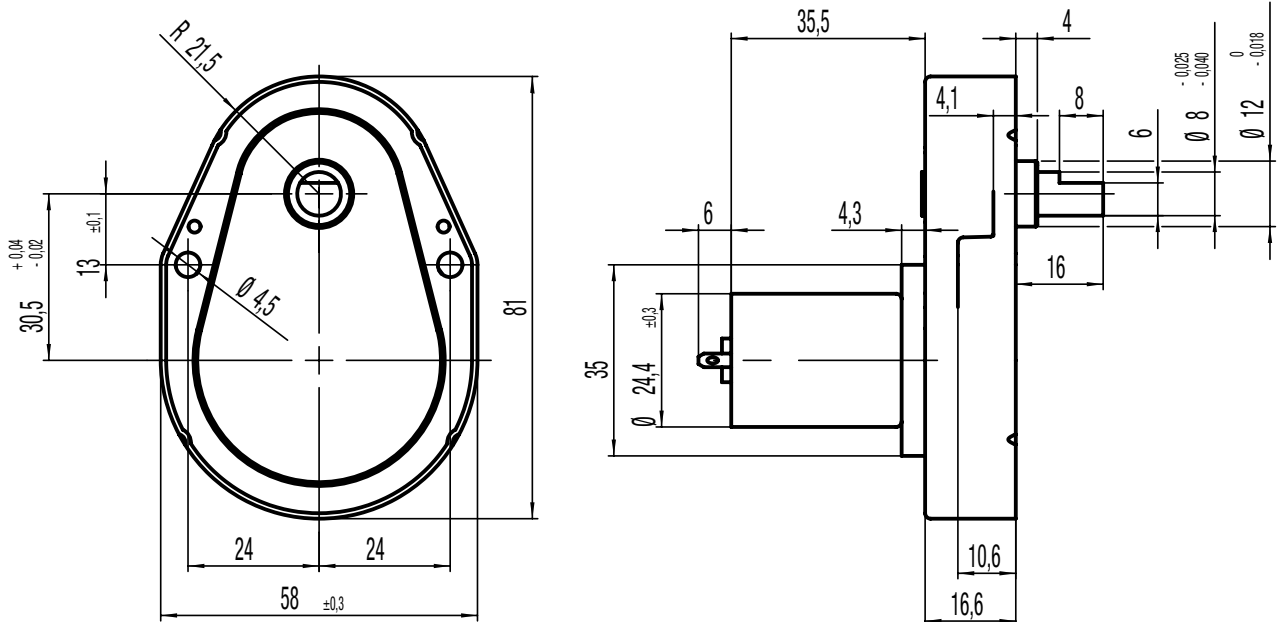

# UGF-DC

## Gearbox UGF with DC Motor HC485G



Voltage (Vdc) 12/24

Max. torque  
(cNm) 400

### Standard Data

Ambient temperature operation	°C -10 ... +55
Ambient temperature storage	°C -20 ... +80
Rotor stalling	not permissible
Approval	standard
Electrical connection	terminals
Mounting	any position
Weight	290 g
Axial thrust	100 N
Lateral force	400 N
Output shaft	∅ 8 × 12 mm (others on request)
Slipping clutch	no
Bearings	sintered bronze, self-lubricating

### Order Reference

Motor type	JP	DC Motor (brushed)	JP	4	A	N	M4	F	33C	N	N	N
Motor size	4	diameter 31.2 mm										
Motor version	A	12 V; no-load speed 4500 rpm										
	B	24 V; no-load speed 4600 rpm										
Approval	N	standard										
Voltage	M1	12 Vdc										
	M4	24 Vdc										
Gearbox size	F											
Gear ratio	33C	333										
Connection	N	terminals, without lead wire										
	A	with lead wire and connector (on request)										
Slipping clutch	N	without slipping clutch										
Shaft end	N	standard shaft ∅ 8 × 12, others on request										

All specifications are representative only and maybe subject to variation. For confirmation of values, please contact Johnson Electric.  
Please also read "Saia Motors Important Notes" on catalog or at [www.johnsonelectric.com/SaiaMotorsNotes](http://www.johnsonelectric.com/SaiaMotorsNotes)

## Technical Data

### Motor JP2A

Voltage supply	V	12
No-load motor speed	rpm	4500
Rated motor speed	rpm	3700
Rated motor current	mA	520
Rated motor torque	cNm	1.0

Gear ratio		125	166	250	333	500	750	1000	1200
Rated output speed	rpm	30	22	15	11	7.5	5	3.7	3.1
Rated output torque	cNm	80	100	150	200	300	400	400	400

### Motor JP2B

Voltage supply	V	24
No-load motor speed	rpm	4600
Rated motor speed	rpm	3900
Rated motor current	mA	260
Rated motor torque	cNm	1.0

Gear ratio		125	166	250	333	500	750	1000	1200
Rated output speed	rpm	31	23	16	12	8	5.2	3.9	3.2
Rated output torque	cNm	80	100	150	200	300	400	400	400

All values approximate. Speed tolerance on request.  
 Output torque permissible max. 400cNm.  
 Continuous duty cycle permissible at rated torque.  
 Higher torque at lower duty cycle on request.  
 Lifetime on request.  
 Other gear ratios on request.

### Dimensions

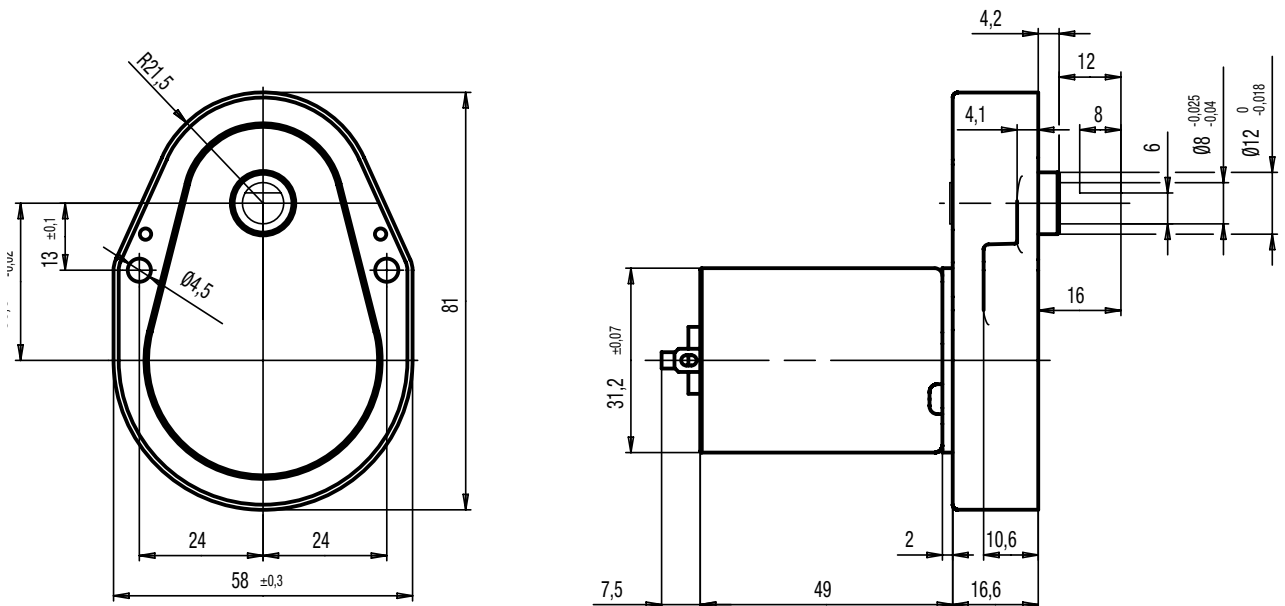

## Gearbox UGO with BLDC Motor E9IDS



Voltage (Vdc)	24
Max. torque (cNm)	600
Characteristics	Driver electronics integrated inside motor
Options	Closed loop speed control Brake feature by relay shortcut circuit

## Standard Data

Ambient temperature operation	°C 0 ... +50
Ambient temperature storage	°C -20 ... +80
Rotor stalling	not permissible
Approval	standard
Electrical connection	connector at motor
Mounting	any position
Weight	500 – 600 g
Axial thrust	30 N
Lateral force	80 N
Output shaft	∅ 8 × 25 mm (others on request)
Slipping clutch	no
Bearings	bronze

## Order Reference

Motor type	JP	BLDC Motor (brushed)	JP	9	B	N	M4	O	75C	A	N	N
Motor size	9	diameter 50 mm										
Motor version	B	24 V; no-load speed 5900 rpm										
Approval	N	standard										
Voltage	M4	24Vdc										
Gearbox size	O											
Gear ratio	75C	750										
Connection	N	lead wires										
	A	with connector at motor										
Slipping clutch	N	without slipping clutch										
Shaft end	N	standard shaft ∅ 8 × 25, others on request										

All specifications are representative only and maybe subject to variation. For confirmation of values, please contact Johnson Electric.  
Please also read "Saia Motors Important Notes" on catalog or at [www.johnsonelectric.com/SaiaMotorsNotes](http://www.johnsonelectric.com/SaiaMotorsNotes)

## Technical Data

Motor JP2A

Voltage supply	V	24
No-load motor speed	rpm	5900
Rated motor speed	rpm	4600
Rated motor current	mA	850
Rated motor torque	cNm	3.0

Gear ratio		18.75	37.5	62.5	93.75	125	187.5	375	750
Rated output speed	rpm	240	120	74	48	37	24	12	6
Rated output torque	cNm	40	80	120	170	230	340	600	600

All values approximate. Speed tolerance on request.  
 Output torque permissible max. 600cNm.  
 Continuous duty cycle permissible at rated torque.  
 Higher torque at lower duty cycle on request.  
 Lifetime on request.  
 Other gear ratios on request.

### Dimensions

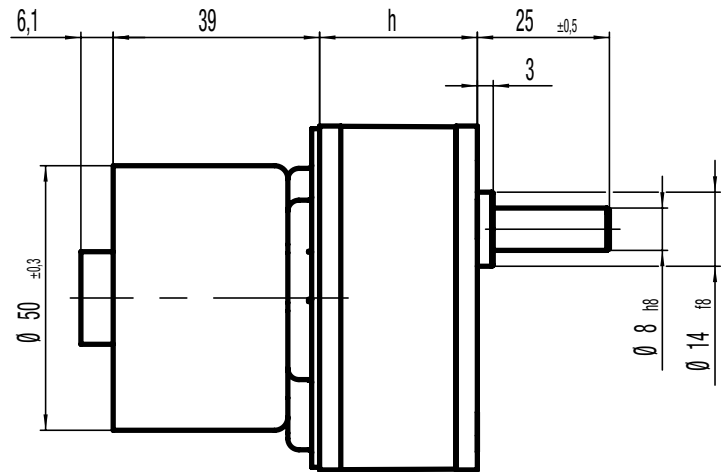
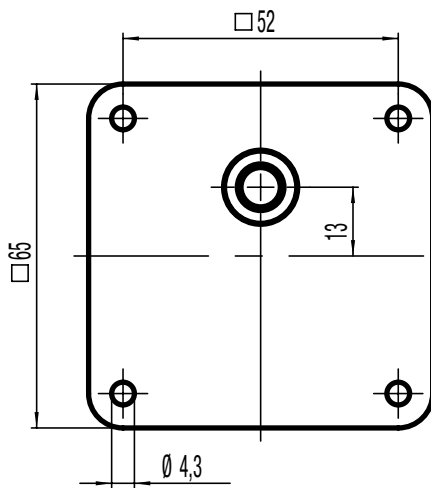

$h = 29,8$  (ratio max. 187,5)  
 $h = 38$  (ratio >187,5)

## Gearbox UGP with DC Motor HC785G

Voltage (Vdc) 24

Max. torque  
(cNm) 600



### Standard Data

Ambient temperature operation	°C 0 ... +50
Ambient temperature storage	°C -20 ... +80
Rotor stalling	not permissible
Approval	standard
Electrical connection	terminals
Mounting	any position
Weight	500 – 600 g
Axial thrust	30 N
Lateral force	80 N
Output shaft	∅ 8 × 25 mm (others on request)
Slipping clutch	no
Bearings	bronze

### Order Reference

Motor type	JP	DC Motor (brushed)	JP	7	B	N	M4	P	37C	N	N	N
Motor size	7	diameter 42 mm										
Motor version	B	24 V; no-load speed 4500 rpm										
Approval	N	standard										
Voltage	M4	24 Vdc										
Gearbox size	P											
Gear ratio	37C	375										
Connection	N	terminals, without lead wire										
	A	with lead wire and connector (on request)										
Slipping clutch	N	without slipping clutch										
Shaft end	N	standard shaft ∅ 8 × 25, others on request										

All specifications are representative only and maybe subject to variation. For confirmation of values, please contact Johnson Electric.  
Please also read "Saia Motors Important Notes" on catalog or at [www.johnsonelectric.com/SaiaMotorsNotes](http://www.johnsonelectric.com/SaiaMotorsNotes)

## Technical Data

Motor JP7B

Voltage supply	V	24
No-load motor speed	rpm	4500
Rated motor speed	rpm	3800
Rated motor current	mA	900
Rated motor torque	cNm	3.5

Gear ratio		18.75	37.5	62.5	93.75	125	187.5	375	750
Rated output speed	rpm	200	100	60	40	30	20	10	5
Rated output torque	cNm	45	90	140	200	270	400	600	600

All values approximate. Speed tolerance on request.  
 Output torque permissible max. 600cNm.  
 Continuous duty cycle permissible at rated torque.  
 Higher torque at lower duty cycle on request.  
 Lifetime on request.  
 Other gear ratios on request.

### Dimensions

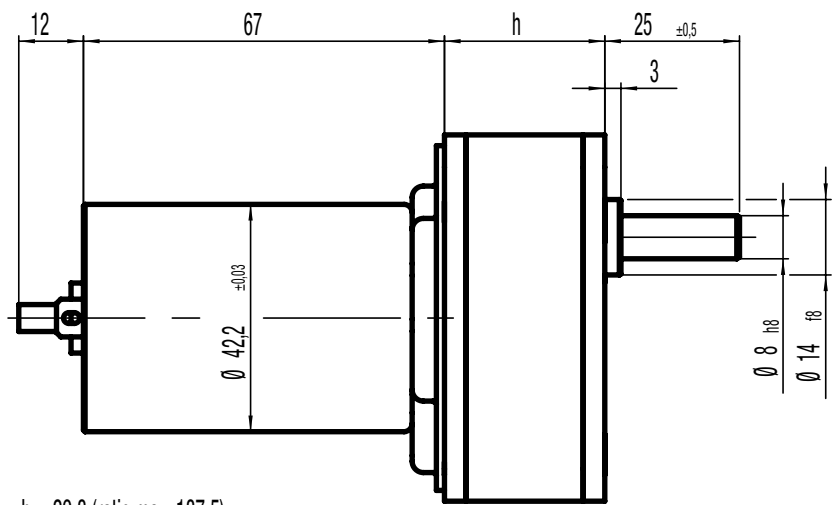
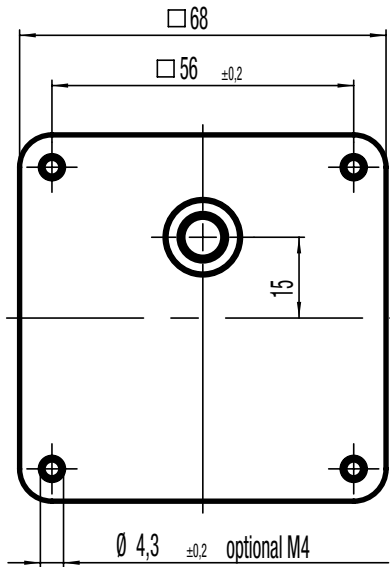

$h = 29,8$  (ratio max. 187,5)  
 $h = 38$  (ratio >187,5)

# Synchronous Motors Linear

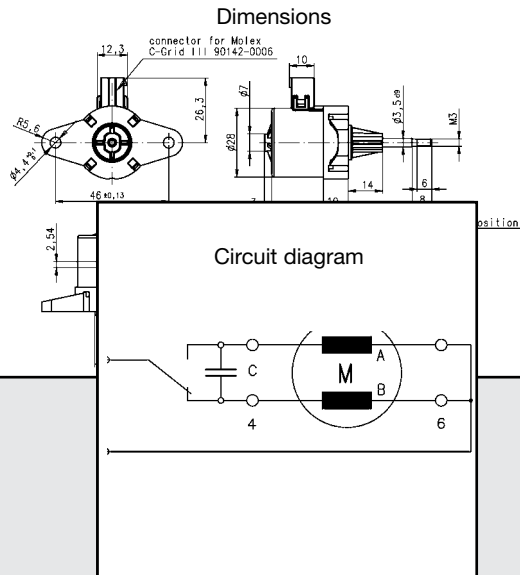



## UCC1/7

Dimensions (mm)	∅ 28 x 31
Travel (mm)	10/13
Voltage (V) **	12–230
Speed (mm/s)	
50 Hz	4.16
60 Hz	5
Max. Force (N)*	48



\* Depends on winding, frequency and lifetime required. Values for connector versions (C, D) / lead wire versions (N) up to 20 % lower. Drive against end stops only permissible after clarification of operating conditions and approval by Saia motors. Radial forces on the shaft will reduce life time and performance.

\*\* regard circuit diagram and connector type

Note: All force and power output values are minimum values, at rated voltage and motor temperature 23°C.

## Standard Data

Climatic class	wide-spread according to DIN IEC 60721-2-1 : 2015
Ambient temperature operation	°C -15 ... +60
Ambient temperature storage	°C -20 ... +100
Thermal resistance at f=0 R <sub>therm</sub>	29 K/W
Thermal class	130 (B) according to DIN EN 60085 : 2008
Winding coil temperature increase	K 60
Approval	standard
Mounting	any position
Electrical connection	connector type C, D, N
Protection	IP40 according to DIN EN 60529 : 2014
Weight	67 g
Rotor stalling	motor can be stopped when voltage is applied, without being overheated
Bearings	ball bearing

## Order Reference

Type	Synchronous Motor	UCC	13	N	B4	D	1B
Configuration	13 standard magnet	73 stronger magnet					
Approval	N						
Voltage/frequency	see next pages						
Connection	C see next pages "Connection Types" and page 145 "Connection Types" for B						
Shaft	1B Travel 13 mm ± 0.7 mm (other standard shafts see under dimensions)						

All specifications are representative only and maybe subject to variation. For confirmation of values, please contact Johnson Electric. Please also read "Saia Motors Important Notes" on catalog or at [www.johnsonelectric.com/SaiaMotorsNotes](http://www.johnsonelectric.com/SaiaMotorsNotes)

## Technical Data

Rated frequency	Hz	50		
Axial speed	mm/s	4.16		
Tolerance of voltage		standard power supply system +10% / -10%		
Linear travel max.	mm	10/13		
Axial play at $\pm 20$ N force	mm	< 0.25		
Winding temperature $T_{max}$		130		
Rated voltage $U_N$	V	12	24	110 <sup>1)</sup>
Duty cycle	%	100	100	100
Resistance $R_{20}$	$\Omega$	53	210	5000
Capacitor $C_{50}$	$\mu F/V \pm 10\%$	18/20	4.7/40	0.22/200
Winding code		B1	B4	C8

Circuit diagram Parallel circuit 12 V, 24 V, 48 V

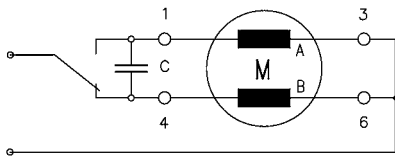

Parallel circuit 230 V (only for connector N) with 110 V motor and resistor  $R_V$

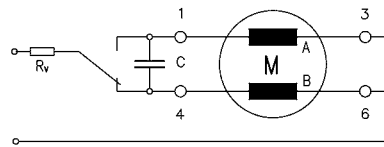

$R_V = 5.6 \text{ k}\Omega, 3 \text{ W}$

Series circuit 110 V (only for connector N)

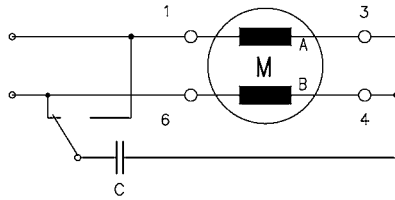

Parallel circuit 230 V (only for connector N) with 110 V motor and capacitor  $C_V$

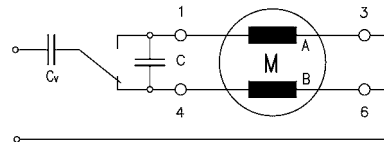

$C_V = 0.33 \mu F, 250 \text{ VAC}$

switch to

- 1 Pull (in)
- 4 Push (out)
- 6 Push (out)  
(for series circuit)

<sup>1)</sup> 110 V version available with 150 mm lead wires AWG26 only  
Standard versions:

Shaft type (see dimensions)	Order code
1B	UCC13NC8N1BZ4
1E	UCC13NC8N1EZ4
1S	UCC13NC8N1SZ4
1R	UCC13NC8N1RZ4
1Q	UCC13NC8N1QZ4

## Dimensions Version with Connector D, with 13 mm travel, shaft 1B and 1E

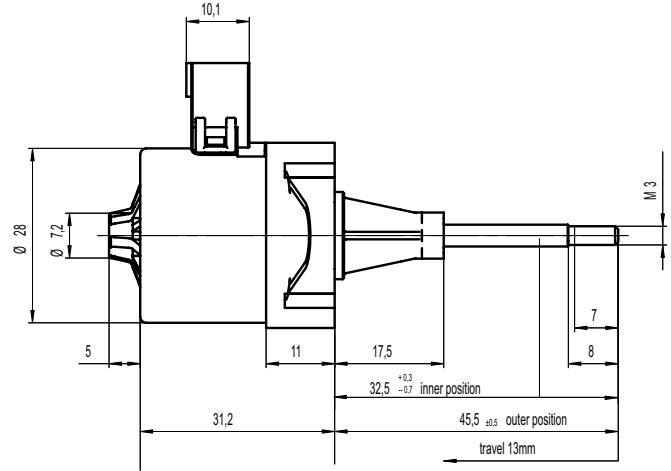
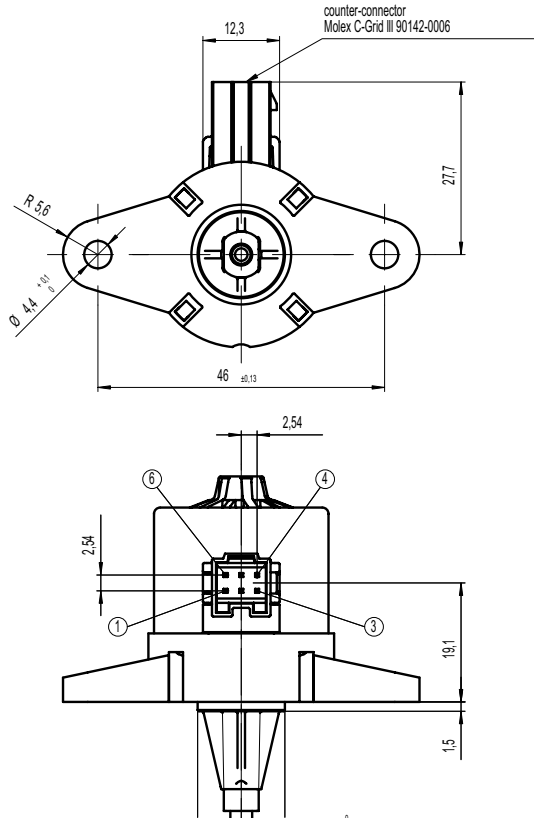

shaft 1B= cost effective solutions for forces up to 25N

## Version with Connector D, with 50..150 mm travel, shaft 1R, 1S, 1Q

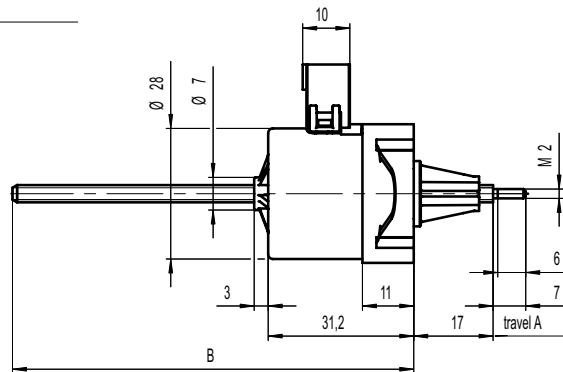
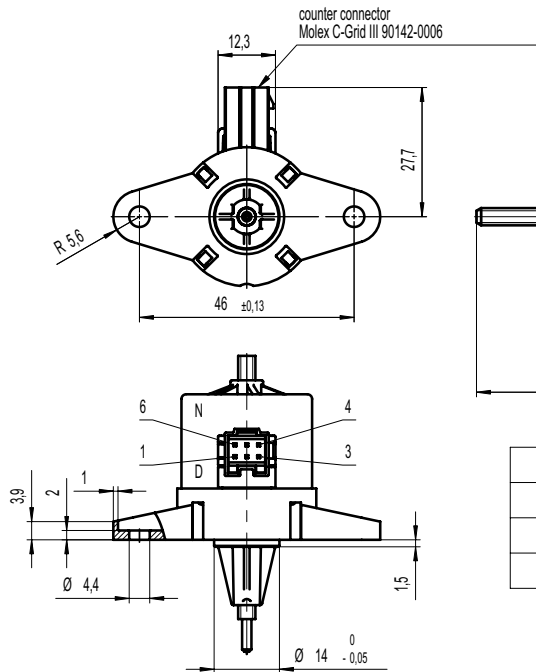

shaft	A	B
1Q	150 mm	186 mm
1R	100 mm	136 mm
1S	50 mm	86 mm

## Dimensions 110 V version with lead wires

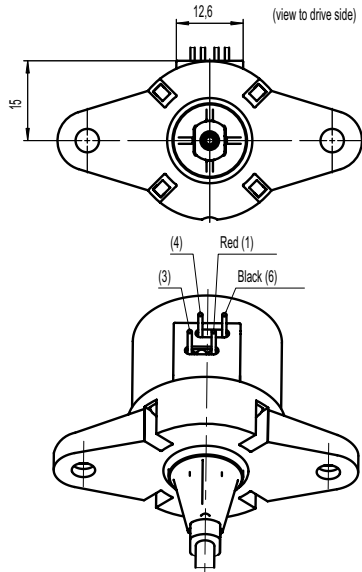

different lead colours for 110V (230V)  
for rotary synchronous motors in series circuit

### Force

		connector version		lead wire version	
		50 Hz	60 Hz	50 Hz	60 Hz
UCC1	100 %	33 N	35 N	26 N	29 N
	30 %	39 N	41 N	31 N	34 N
UCC7	100 %	39 N	41 N	32 N	35 N
	30 %	47 N	48 N	38 N	42 N

## UCK 1/7

Dimensions (mm)	∅ 28 x 31
Travel (mm)	10/13
Voltage (V) **	12–230
Speed (mm/s)	
50 Hz	8.33
60 Hz	10
Max. Force (N)*	49



\* Depends on winding, frequency and lifetime required. Values for connector versions (C, D) / lead wire versions (N) up to 20 % lower.  
 Drive against end stops only permissible after clarification of operating conditions and approval by Saia motors.  
 Radial forces on the shaft will reduce life time and performance.

\*\* regard circuit diagram and connector type

Note: All force and power output values are minimum values, at rated voltage and motor temperature 23°C.

## Standard Data

Climatic class	wide-spread according to DIN IEC 60721-2-1 : 2015
Ambient temperature operation	°C -15 ... +60
Ambient temperature storage	°C -20 ... +100
Thermal resistance at f=0 R <sub>therm</sub>	29 K/W
Thermal class	130 (B) according to DIN EN 60085 : 2008
Winding coil temperature increase	K 60
Approval	standard
Mounting	any position
Electrical connection	connector type C, D, N
Protection	IP40 according to DIN EN 60529 : 2014
Weight	67 g
Rotor stalling	motor can be stopped when voltage is applied, without being overheated
Bearings	ball bearing

## Order Reference

Type	Synchronous Motor	UCK	13	N	B4	D	1B
Configuration	13 standard magnet	73 stronger magnet					
Approval	N						
Voltage/frequency	see next page						
Connection	C see next pages "Connection Types" and page 145 "Connection Types" for B						
Shaft	1B Travel 13 mm ± 0.7 mm (other standard shafts see under dimensions)						

All specifications are representative only and maybe subject to variation. For confirmation of values, please contact Johnson Electric.  
 Please also read "Saia Motors Important Notes" on catalog or at [www.johnsonelectric.com/SaiaMotorsNotes](http://www.johnsonelectric.com/SaiaMotorsNotes)

## Technical Data

Rated frequency	Hz	50		
Speed	mm/s	8.33		
Tolerance of voltage		standard power supply system +10% / -10%		
Axial play at 20 N force	mm	< 0.25		
Duty cycle		100 %		
Winding temperature $T_{max}$		130		
Rated voltage $U_N$	V	12	24	110 <sup>1)</sup>
Duty cycle	%	100	100	100
Resistance $R_{20}$	$\Omega$	59	230	5500
Capacitor $C_{50}$	$\mu F / V \pm 10\%$	22/20	5.6/40	0.27/200
Winding code		B1	B4	C8/H8

Circuit diagram Parallel circuit 12 V, 24 V, 48 V

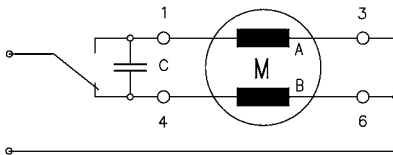

Parallel circuit 230 V (only for connector N) with 110 V motor and resistor  $R_V$

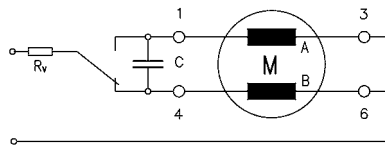

$R_V = 5.6 \text{ k}\Omega, 3 \text{ W}$

switch to

- 1 Pull (in)
- 4 Push (out)
- 6 Push (out) (for series circuit)

Series circuit 110 V (only for connector N)

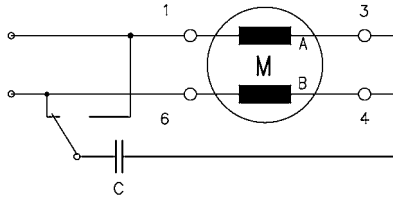

Parallel circuit 230 V (only for connector N) with 110 V motor and capacitor  $C_V$

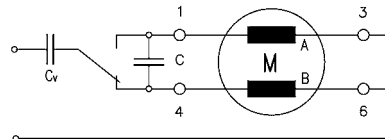

$C_V = 0.33 \mu F, 250 \text{ VAC}$

<sup>1)</sup> 110 V version available with 150 mm lead wires AWG26 only  
Standard versions:

Shaft type (see dimensions)	Order code
1B	UCK13NC8N1BZ2
1E	UCK13NC8N1EZ2
1S	UCK13NC8N1SZ2
1R	UCK13NC8N1RZ2
1Q	UCK13NC8N1QZ2

## Dimensions Version with Connector D, with 13 mm travel, shaft 1B and 1E

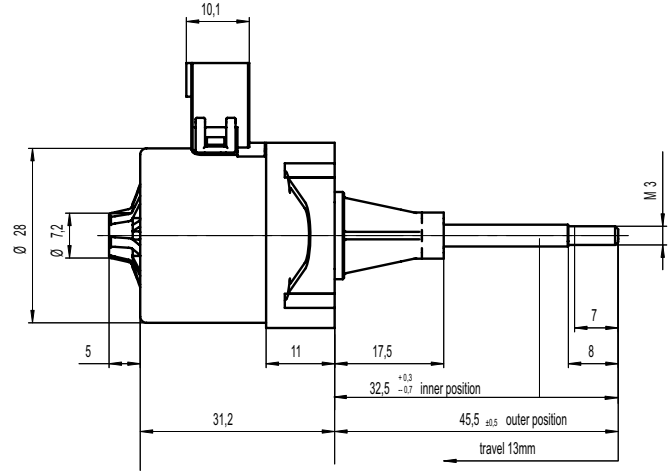
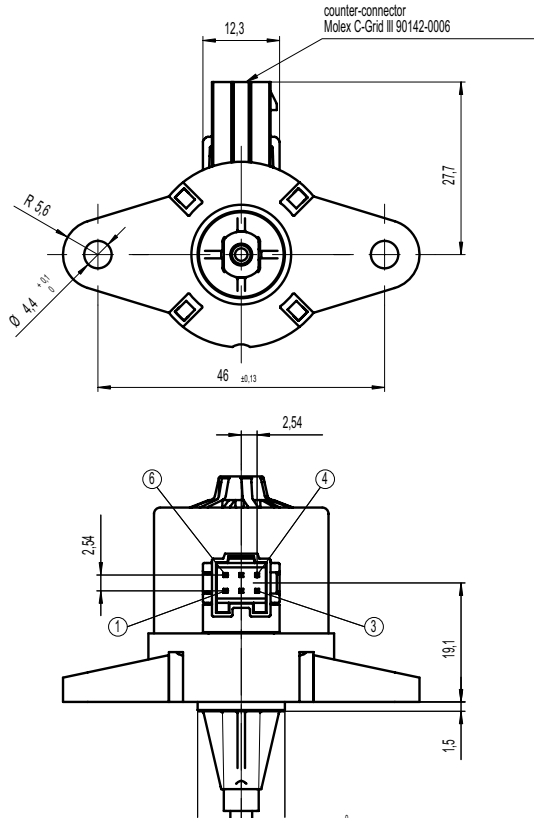

shaft 1B= cost effective solutions for forces up to 25N

## Version with Connector D, with 50..150 mm travel, shaft 1R, 1S, 1Q

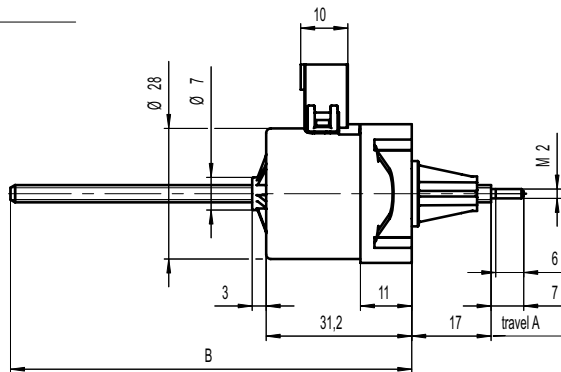
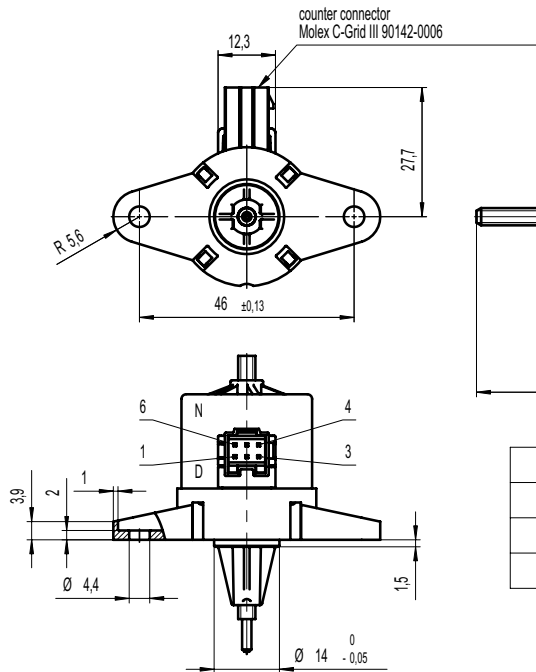

shaft	A	B
1Q	150 mm	186 mm
1R	100 mm	136 mm
1S	50 mm	86 mm

## Dimensions 110 V version with lead wires

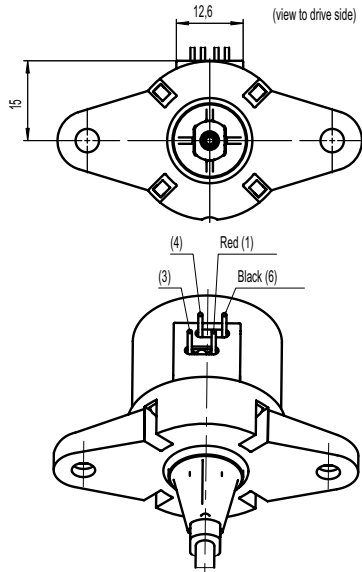

different lead colours for 110V (230V)  
for rotary synchronous motors in series circuit

### Force

		connector version		lead wire version	
		50 Hz	60 Hz	50 Hz	60 Hz
UCK1	100 %	27 N	28 N	19 N	19 N
	30 %	35 N	41 N	24 N	26 N
UCK7	100 %	34 N	33 N	22 N	21 N
	30 %	44 N	49 N	29 N	30 N





## UAL 1/5; UAL 2

Dimensions (mm)	20 x 30
Travel (mm)	15
Travel per step (mm)	0,021
Thread pitch (mm)	0,5
Speed (mm/s) at 200 Hz	4,16
Step angle (°)	15
Max. Force (N)*	40



\*Depends on winding, frequency and lifetime required.

Drive against end stops only permissible after clarification of operating conditions and approval by Saia Motor.

Radial forces on the shaft will reduce life time and performance.

Note: All force and power output values are minimum values, at rated voltage and motor temperature 23°C.

## Standard Data

Climatic class	wide-spread according to DIN IEC 60721-2-1 : 2015
Ambient temperature operation	°C -15 ... +60
Ambient temperature storage	°C -20 ... +100
Thermal resistance at f=0 R <sub>them</sub>	47 K/W
Thermal class	130 (B) according to DIN EN 60085 : 2008
Approval	standard
Mounting	any position
Electrical connection	lead wire with CT connector
Protection	IP40 according to DIN EN 60529 : 2014
Weight	33 g
Rotor stalling	motor can be stopped when voltage is applied, without being overheated
Bearings	ball bearing

## Order Reference

Type	Stepper Motor	UAL	1E	N	01	E	1A
Configuration	1A bipolar, standard magnet, screw flange 1E bipolar, standard magnet, bayonet flange 2A unipolar, standard magnet, screw flange 2E unipolar, standard magnet, bayonet flange 5A bipolar, stronger magnet, screw flange 5E bipolar, stronger magnet, bayonet flange						
Approval	N standard						
Winding code	see next page, resistance per winding for bipolar or unipolar						
Connection	E 100 mm lead wire with CT connector						
Shaft	1A Travel 15 mm ± 0,7 mm (others on request)						

All specifications are representative only and maybe subject to variation. For confirmation of values, please contact Johnson Electric.  
Please also read "Saia Motors Important Notes" on catalog or at [www.johnsonelectric.com/SaiaMotorsNotes](http://www.johnsonelectric.com/SaiaMotorsNotes)

## Technical Data

Steps per mm		48
Winding temperature $T_{max}$	°C	130
Linear travel max.	mm	15
Axial play at 20 N force	mm	0,25

unipolar versions available upon request

bipolar	Rated voltage $U_N$	V	6	12	24
	Duty cycle	%	100	100	100
	Resistance $R_{20}$	$\Omega$	40	150	610
	Winding code		03	01	04

\* measured at 23 °C, lifetime depends on load characteristics and ambient conditions

Circuit diagram bipolar

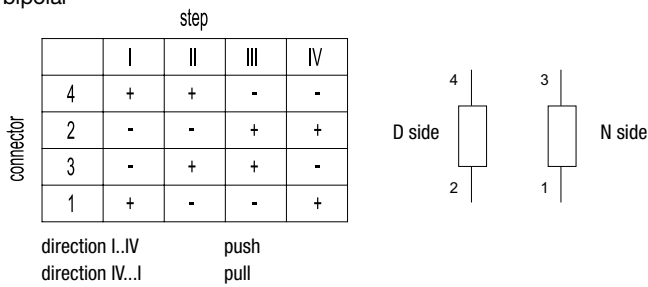

unipolar

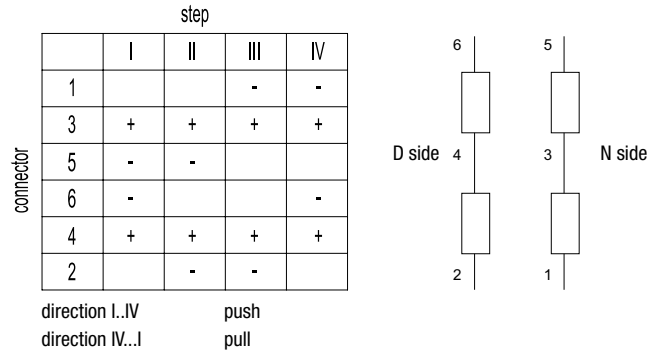

Dimensions Version with 100 mm leads and CT connector, 15 mm travel

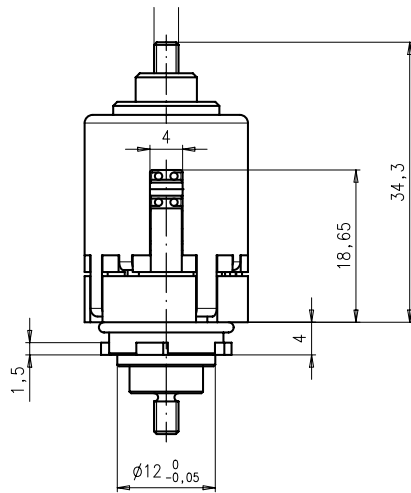
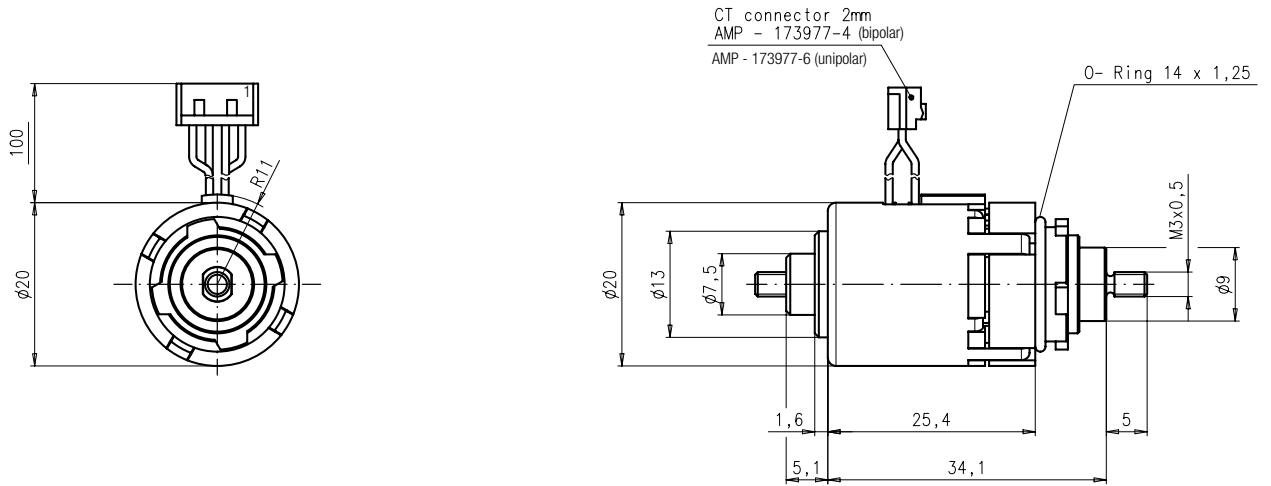

Connecting dimensions of direct bayonet mount

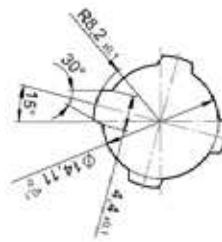

Material thickness 1,5 mm

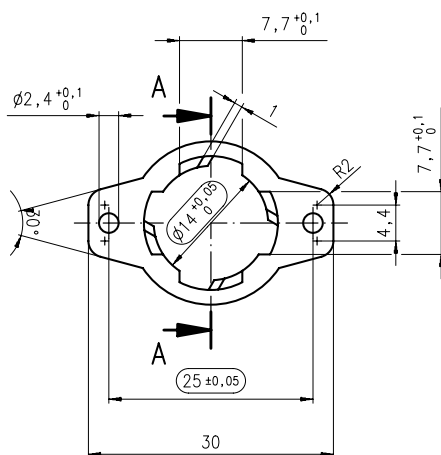

## Performance Chart

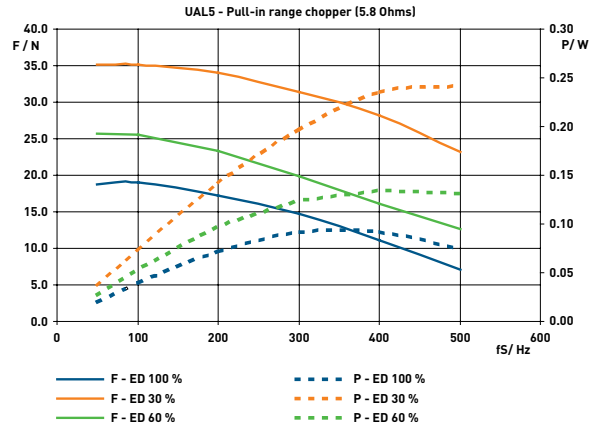
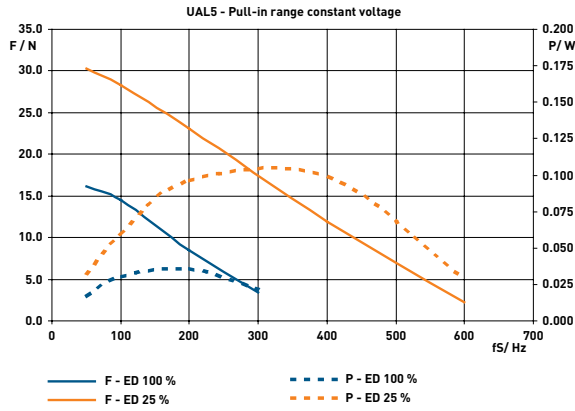
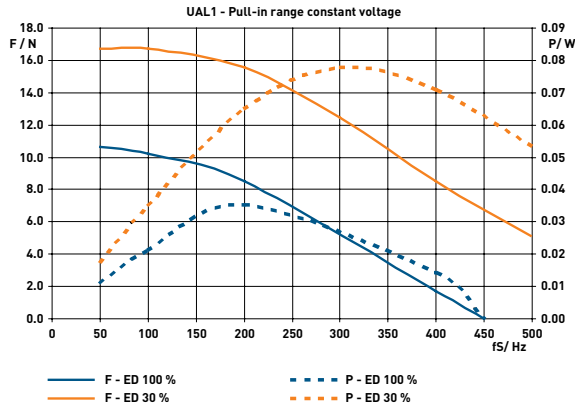

100% duty cycle: max. current per phase 300 mA  
 60% duty cycle: max. current per phase 360 mA  
 30% duty cycle: max. current per phase 500 mA

## UCE1/7; UCE2/8

Dimensions (mm)	∅ 28 x 31
Travel (mm)	10/13
Travel per step (mm)	0.021
Speed (mm/s) at 200 Hz	4.16
Max. Force (N)*	80



\*Depends on winding, frequency and lifetime required.  
 Drive against end stops only permissible after clarification of operating conditions and approval by Saia Motors.  
 Radial forces on the shaft will reduce life time and performance.  
 Note: All force and power output values are minimum values, at rated voltage and motor temperature 23°C.

## Standard Data

Climatic class	wide-spread according to DIN IEC 60721-2-1 : 2015
Ambient temperature operation	°C -15 ... +60
Ambient temperature storage	°C -20 ... +100
Thermal resistance at f=0 R <sub>therm</sub>	29 K/W
Thermal class	130 (B) according to DIN EN 60085 : 2008
Approval	standard
Mounting	any position
Electrical connection	connector type C, D
Protection	IP40 according to DIN EN 60529 : 2014
Weight	67 g
Rotor stalling	motor can be stopped when voltage is applied, without being overheated
Bearings	ball bearing

## Order Reference

Type	Stepper Motor	UCE	13	N	01	D	1B
Configuration	13 bipolar, standard magnet	73 bipolar, stronger magnet					
	23 unipolar, standard magnet	83 unipolar, stronger magnet					
Approval	N						
Resistance	see next page, Resistance per winding for bipolar or unipolar						
Connection	C see next pages "Connection Types" and page 145 "Connection Types" for B D						
Shaft	1B Travel 13 mm ± 0.7 mm (other standard shafts see under dimensions)						

All specifications are representative only and maybe subject to variation. For confirmation of values, please contact Johnson Electric.  
 Please also read "Saia Motors Important Notes" on catalog or at [www.johnsonelectric.com/SaiaMotorsNotes](http://www.johnsonelectric.com/SaiaMotorsNotes)

## Technical Data

bipolar	Rated voltage $U_N$ :	V	6	12	24
	Resistance per winding $R_{20}$	$\Omega$	24	90	380
Travel per step		mm	0.021		
Winding temperature $T_{max}$		$^{\circ}\text{C}$	130		
Axial play at $\pm 20$ N force		mm	< 0.25		

Circuit diagram bipolar

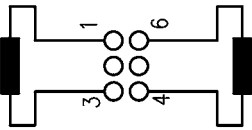

stepping sequence number

	I	II	III	IV	I
1	+	+	-	-	+
3	-	-	+	+	-
4	-	+	+	-	-
6	+	-	-	+	+

pin number

→ Pull in (step I to IV, I to IV, etc.)  
← Push out (step IV to I, step IV to I, etc.)

unipolar

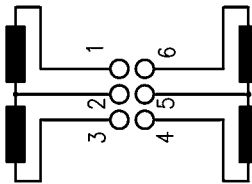

stepping sequence number

	I	II	III	IV	I
1	-	-			-
2	+	+	+	+	+
3			-	-	
4		-	-		
5	+	+	+	+	+
6	-			-	-

pin number

→ Pull in (step I to IV, I to IV, etc.)  
← Push out (step IV to I, step IV to I, etc.)

## Dimensions

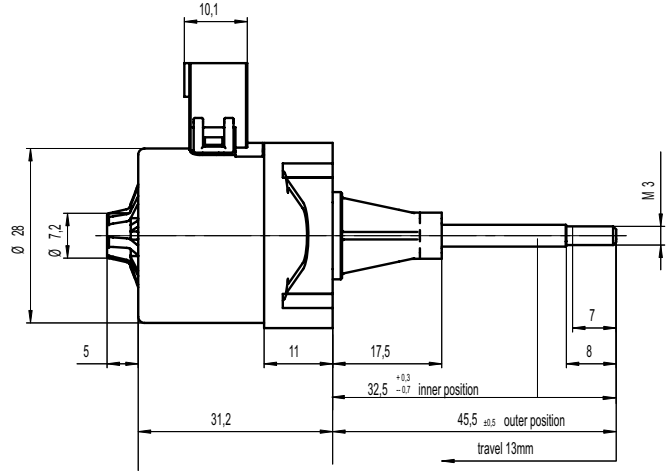
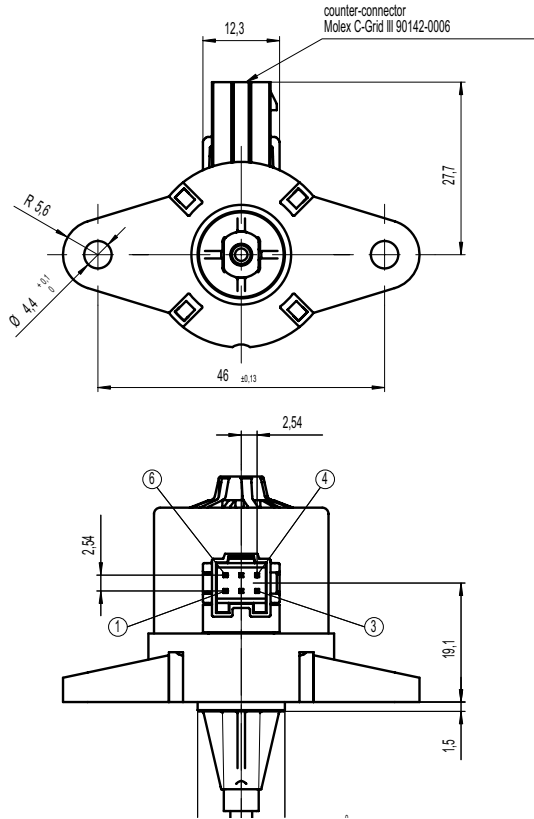

shaft 1B= cost effective solutions for forces up to 25N

Version with Connector D, with 50..150 mm travel, shaft 1R, 1S, 1Q

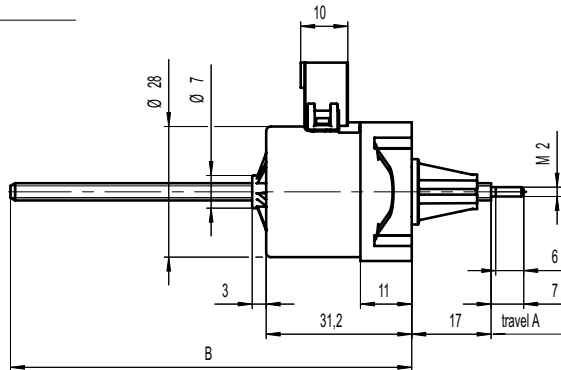
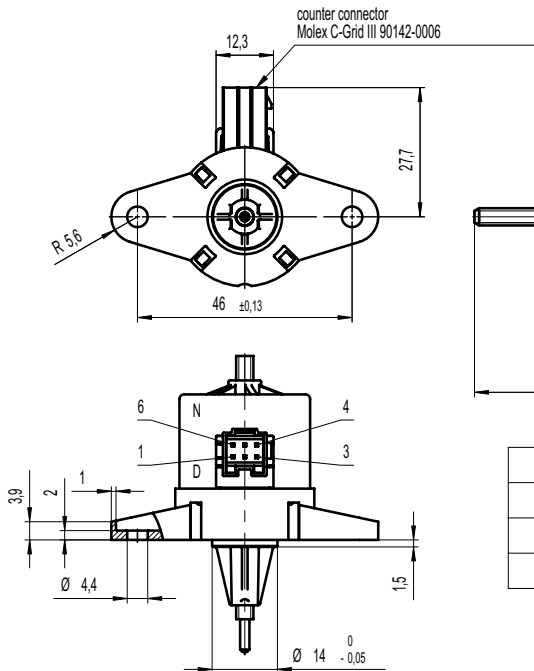

shaft	A	B
1Q	150 mm	186 mm
1R	100 mm	136 mm
1S	50 mm	86 mm



## Performance Chart

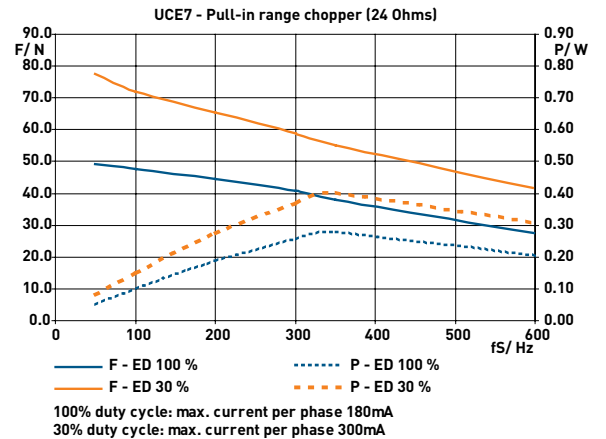
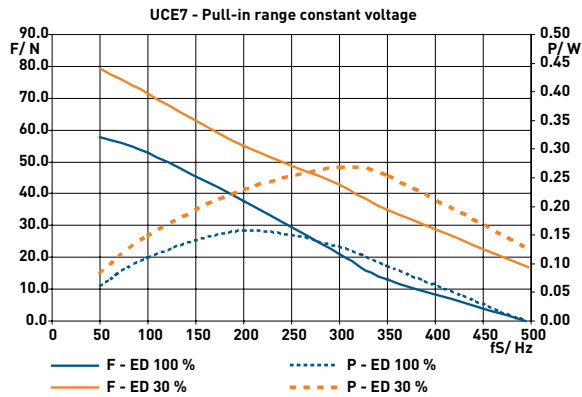
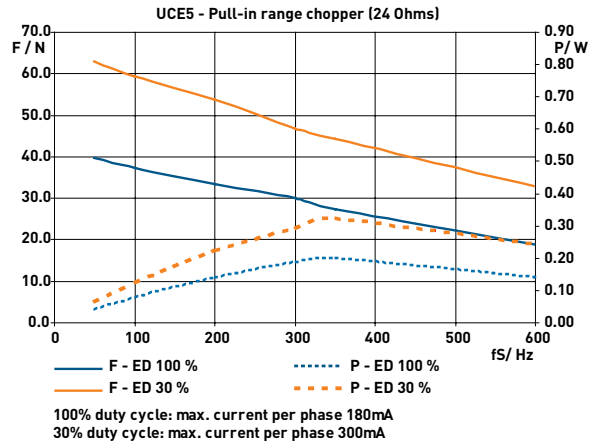
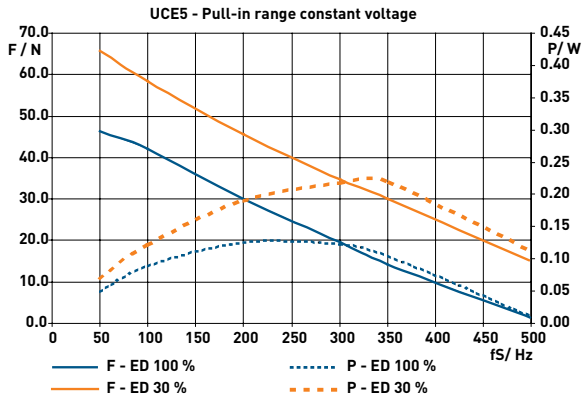
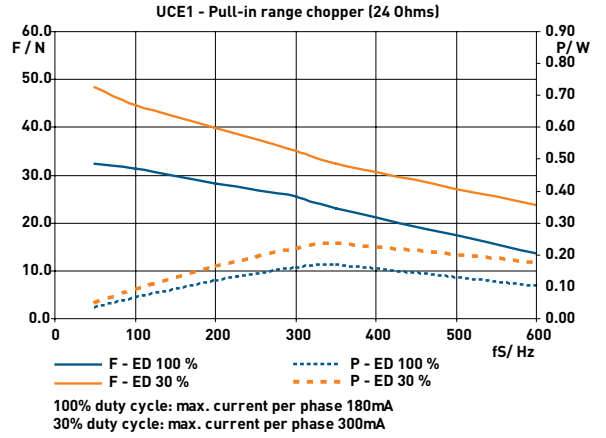
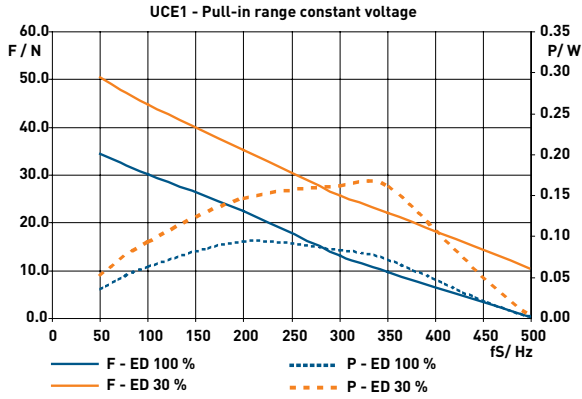

## Performance Chart

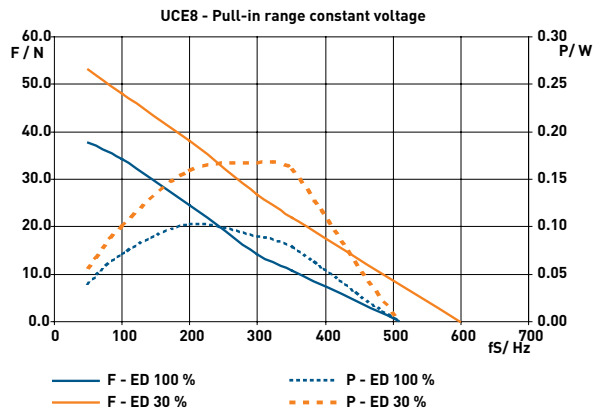
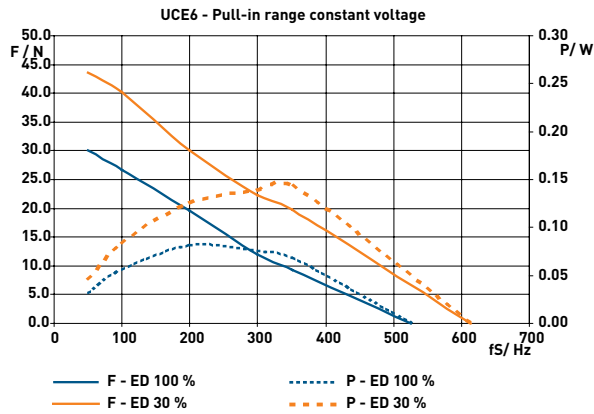
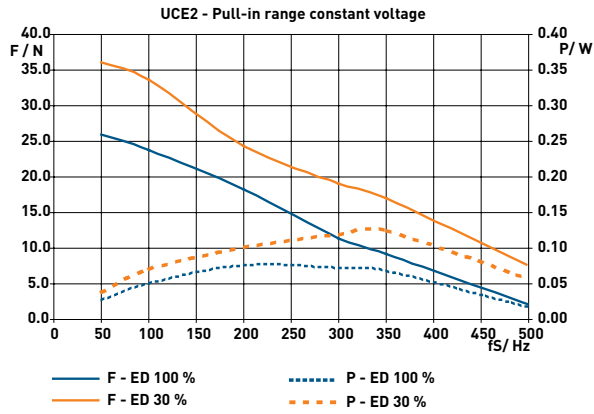

## UCL1/7; UCL2/8

Dimensions (mm)	∅ 28 x 31
Travel (mm)	10/13
Travel per step (mm)	0.041
Speed (mm/s) at 200 Hz	8.33
Max. Force (N)*	70



\*Depends on winding, frequency and lifetime required.  
 Drive against end stops only permissible after clarification of operating conditions and approval by Saia Motors.  
 Radial forces on the shaft will reduce life time and performance.  
 Note: All force and power output values are minimum values, at rated voltage and motor temperature 23°C.

## Standard Data

Climatic class	wide-spread according to DIN IEC 60721-2-1 : 2015
Ambient temperature operation	°C -15 ... +60
Ambient temperature storage	°C -20 ... +100
Thermal resistance at f=0 R <sub>therm</sub>	29 K/W
Thermal class	130 (B) according to DIN EN 60085 : 2008
Approval	standard
Mounting	any position
Electrical connection	connector type C, D
Protection	IP40 according to DIN EN 60529 : 2014
Weight	67 g
Rotor stalling	motor can be stopped when voltage is applied, without being overheated
Bearings	ball bearing

## Order Reference

Type	Stepper Motor				UCL	13	N	01	D	1B
Configuration	13	bipolar, standard magnet	73	bipolar, stronger magnet						
	23	unipolar, standard magnet	83	unipolar, stronger magnet						
Approval	N									
Resistance	see next page, Resistance per winding for bipolar or unipolar									
Connection	C see pages 151, „Connection Types“ D									
Shaft	1B Travel 13 mm ± 0.7 mm (other standard shafts see under dimensions)									

All specifications are representative only and maybe subject to variation. For confirmation of values, please contact Johnson Electric.  
 Please also read "Saia Motors Important Notes" on catalog or at [www.johnsonelectric.com/SaiaMotorsNotes](http://www.johnsonelectric.com/SaiaMotorsNotes)

## Technical Data

bipolar	Rated voltage $U_N$ :	V	6	12	24
	Duty cycle	%	100	100	100
	Resistance $R_{20}$	$\Omega$	24	90	380
	Winding code		05	02	01
unipolar	Rated voltage $U_N$ :	V	6	12	24
	Duty cycle	%	100	100	100
	Resistance $R_{20}$	$\Omega$	24	90	380
	Winding code		07	08	01
	Travel per step	mm	0.042		
	Winding temperature $T_{max}$	$^{\circ}\text{C}$	130		
	Axial play at $\pm 20$ N force	mm	< 0.25		

Circuit diagram bipolar

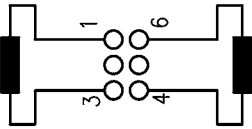

stepping sequence number

	I	II	III	IV	I
pin number 1	+	+	-	-	+
pin number 3	-	-	+	+	-
pin number 4	-	+	+	-	-
pin number 6	+	-	-	+	+

Pull in (step I to IV, I to IV, etc.)  
 Push out (step IV to I, step IV to I, etc.)

unipolar

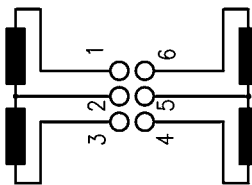

stepping sequence number

	I	II	III	IV	I
pin number 1	-	-			-
pin number 2	+	+	+	+	+
pin number 3			-	-	
pin number 4		-	-		
pin number 5	+	+	+	+	+
pin number 6	-			-	-

Pull in (step I to IV, I to IV, etc.)  
 Push out (step IV to I, step IV to I, etc.)

## Dimensions Version with Connector D, with 13 mm travel, shaft 1B and 1E

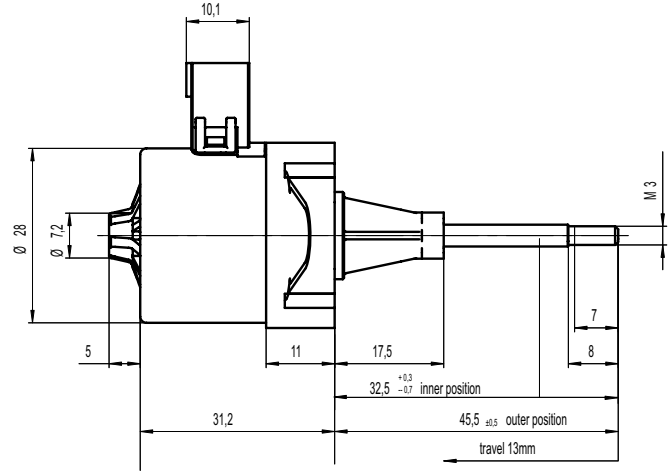
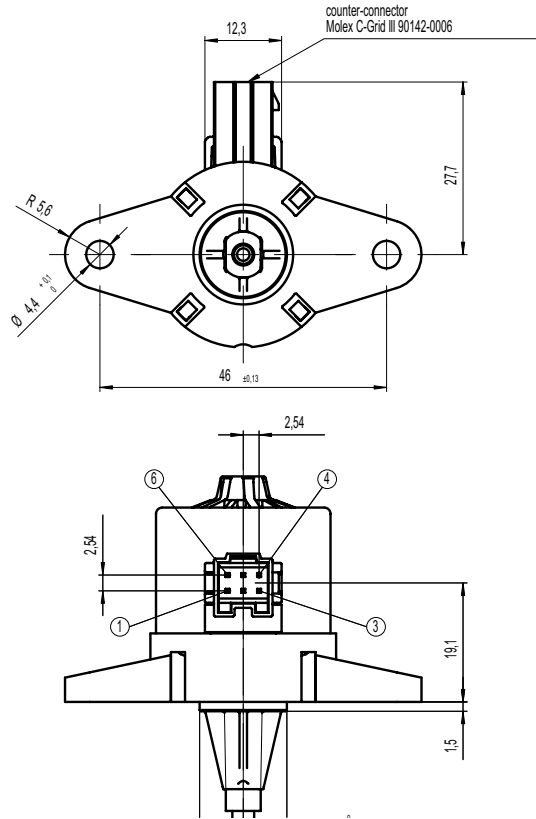

shaft 1B= cost effective solutions for forces up to 25N

## Version with Connector D, with 50..150 mm travel, shaft 1R, 1S, 1Q

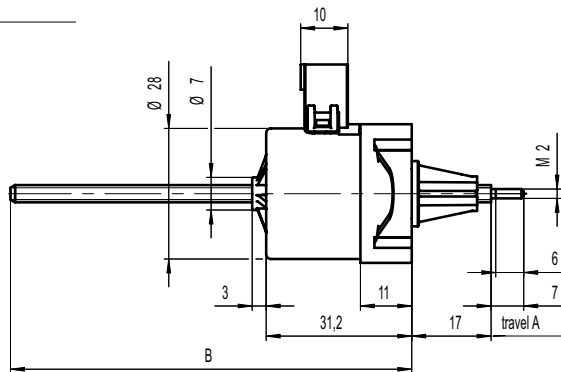
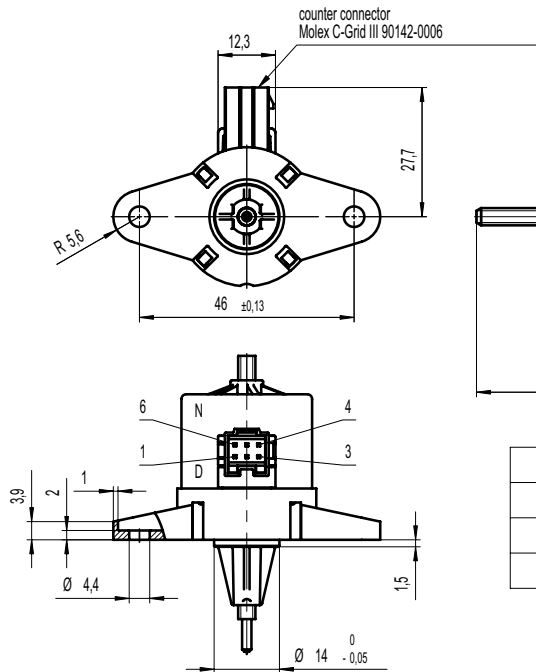

shaft	A	B
1Q	150 mm	186 mm
1R	100 mm	136 mm
1S	50 mm	86 mm

## Performance Chart

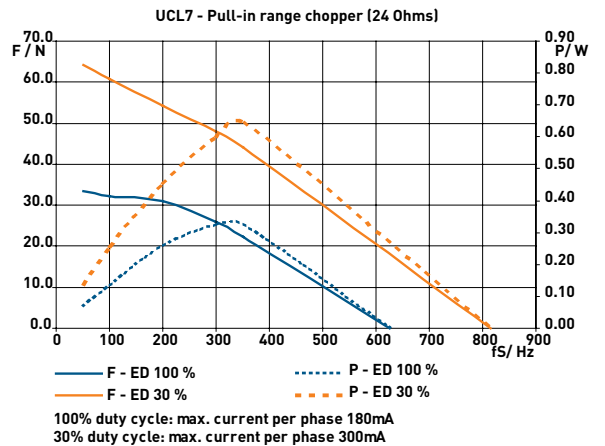
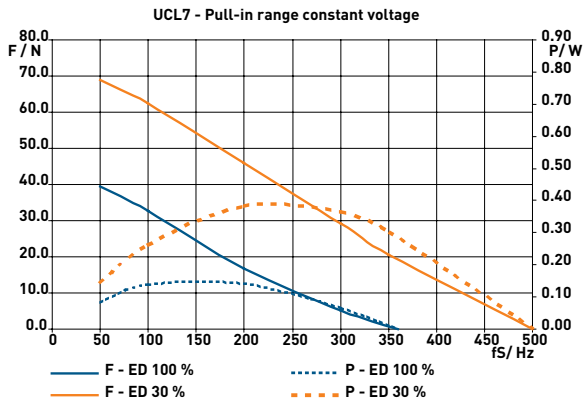
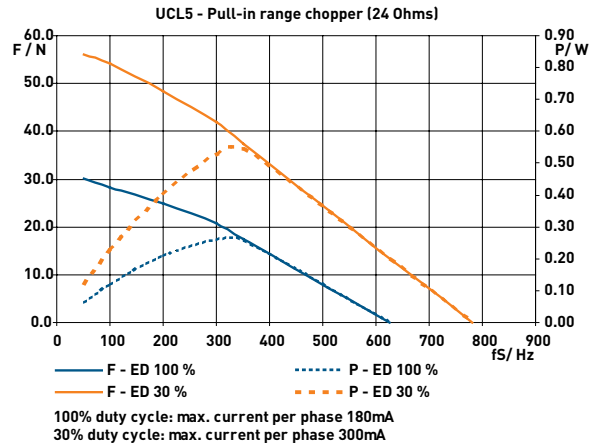
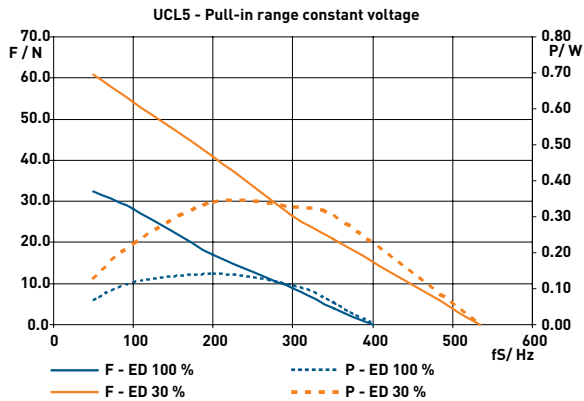
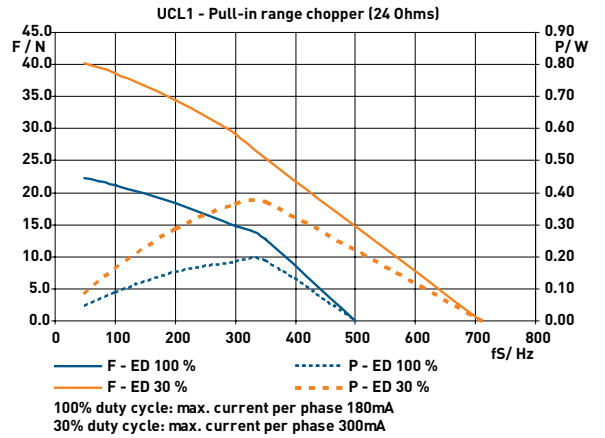
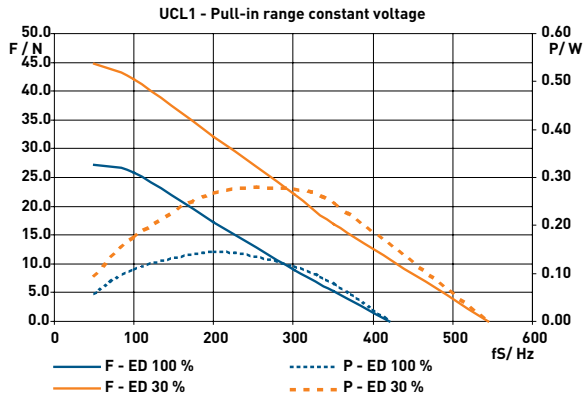

## Performance Chart

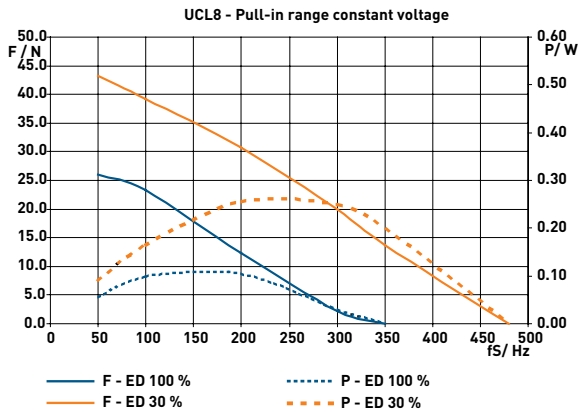
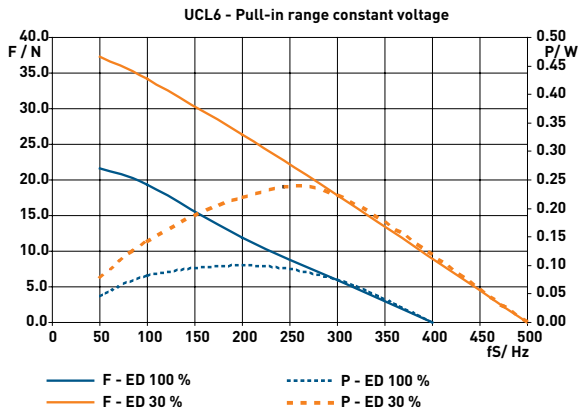
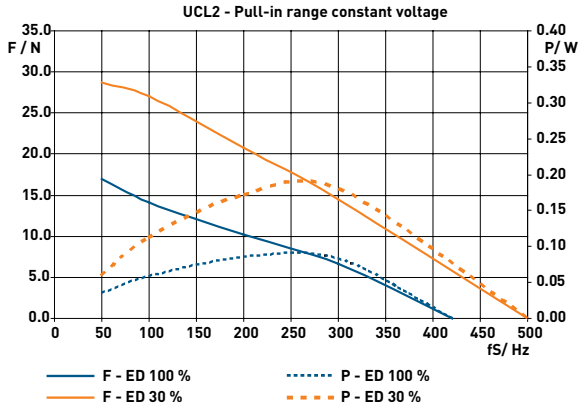

# Connection Types UC motors

**Connector B**  
for Molex Mini-Grid 51110-0660

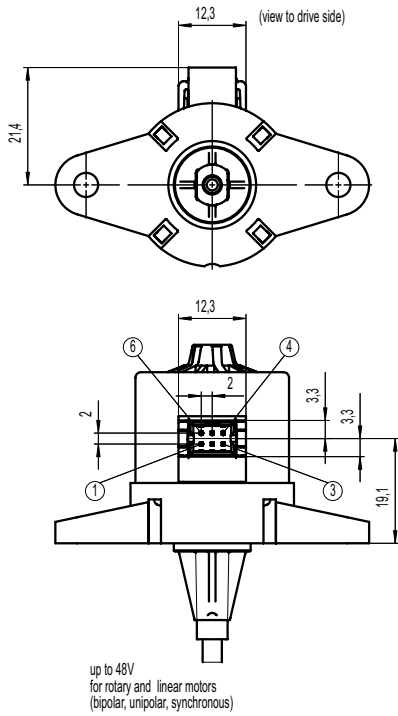

**Connector C**  
for Tyco Modu IV 0-1740209-6

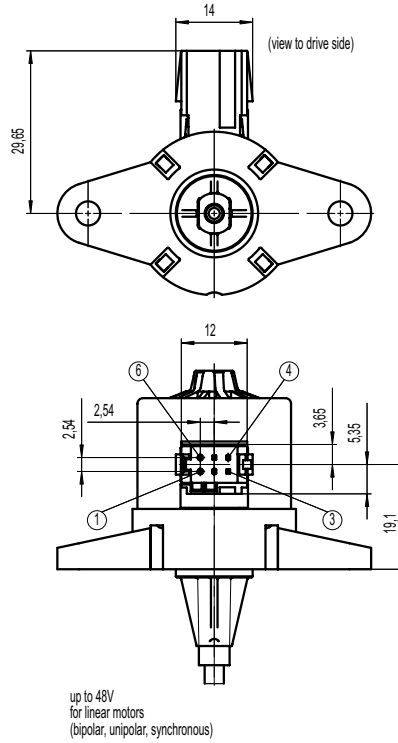

**Connector D**  
for Molex C-Grid III 90142-0005

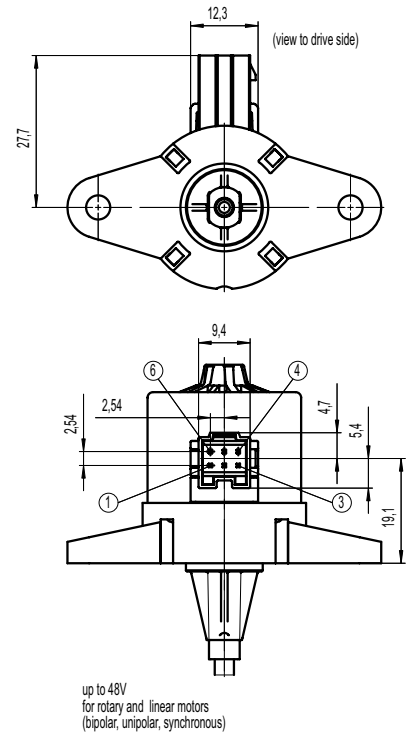



# Electronics for Stepper Motors

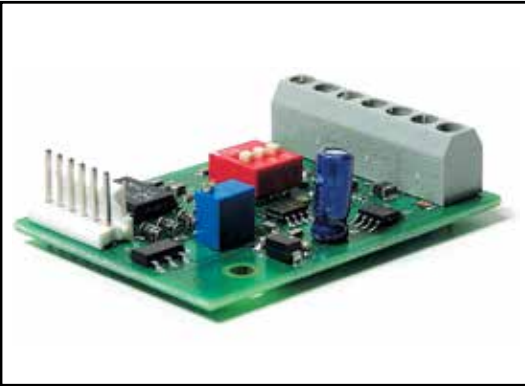

Dimensions

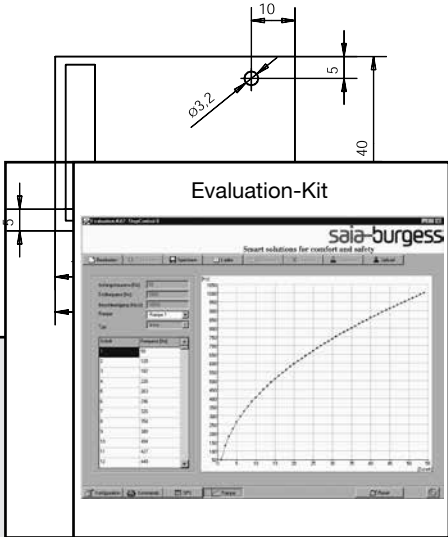

## SAMOTRONIC101



Driver	for unipolar motors
Dimensions (mm)	55 x 40
Supply voltage (VDC)	10-24
Motor current	constant voltage drive
Step mode	full/half step
Clock source	internal or external
Control inputs to	<ul style="list-style-type: none"> <li>■ inhibit internal clock</li> <li>■ inhibit motor current</li> <li>■ change direction of rotations</li> </ul>
Configuration	via DIP-switch, potentiometer

## Preferred Range

Ordering Reference	
4 636 6608 0	If motors are also to be ordered please state: "with MTA-100 receptacles for use with SAMOTRONIC101".
4 636 6608 3	with screw terminal for motor connection, max 0.5 mm <sup>2</sup>

## Technical Data

Supply voltage	10-24 VDC
Phase current	≤ 350 mA
Control signal level	LS-TTL (0-5V) for all control inputs
Internal clock	50-360 Hz
External clock	up to 2 kHz
Dimensions	55 x 40 mm
Operating temperature	-5 to +50 °C
Storage temperature	-20 to +70 °C

Dimensions

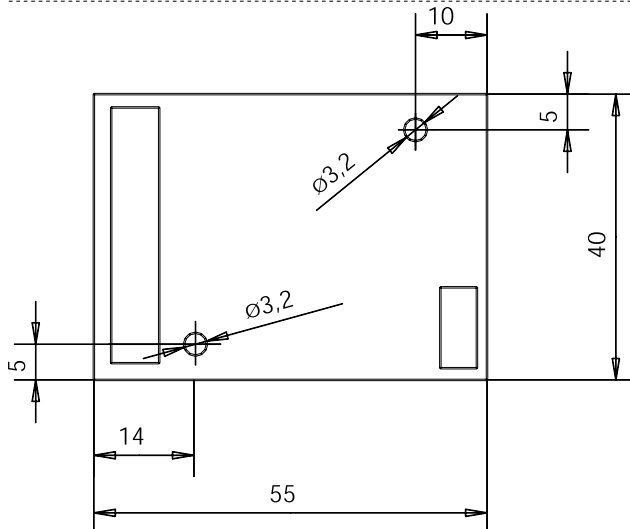

For latest technical and safety compliance information regarding these products, please download the relevant data sheet from our web site: [www.saia-burgess.com/drivers](http://www.saia-burgess.com/drivers)

*All specifications are representative only and maybe subject to variation. For confirmation of values, please contact Johnson Electric. Please also read "Saia Motors Important Notes" on catalog or at [www.johnsonelectric.com/SaiaMotorsNotes](http://www.johnsonelectric.com/SaiaMotorsNotes)*

## SAMOTRONIC102

Driver	for bipolar motors
Dimensions (mm)	84 x 54
Supply voltage (VDC)	<ul style="list-style-type: none"> <li>■ standard version 10 DC-24</li> <li>■ enhanced version 10 DC-42</li> </ul>
Motor current	<ul style="list-style-type: none"> <li>■ constant current drive (chopper controlled)</li> <li>■ adjustable via potentiometer</li> </ul>
Step mode	full/half step
Clock source	internal or external
Control inputs to	<ul style="list-style-type: none"> <li>■ inhibit internal clock</li> <li>■ inhibit motor current</li> <li>■ change direction of rotations</li> </ul>
Configuration	via DIP-switch, potentiometer
Test pins	<ul style="list-style-type: none"> <li>■ motor current</li> <li>■ step frequency</li> </ul>



## Preferred Range

### Ordering Reference

4 636 6733 0	10-24VDC supply voltage (standard version)
4 636 6733 3	10-42VDC supply voltage (enhanced version)

If motors are also to be ordered please state: "with MTA-100 receptacles for use with SAMOTRONIC102".

## Technical Data

Supply voltage	10-24 (42)VDC
Phase current	71-500 mA, on request max. 735mA/ph
Chopper frequency	typ. 20kHz
Control signal level	LS-TTL (0-5V) for all control inputs
Internal clock	50-1325 Hz
External clock	up to 2 kHz
Dimensions	84 x 54 mm
Operating temperature	-20 to +60 °C
Storage temperature	-20 to +80 °C

### Dimensions

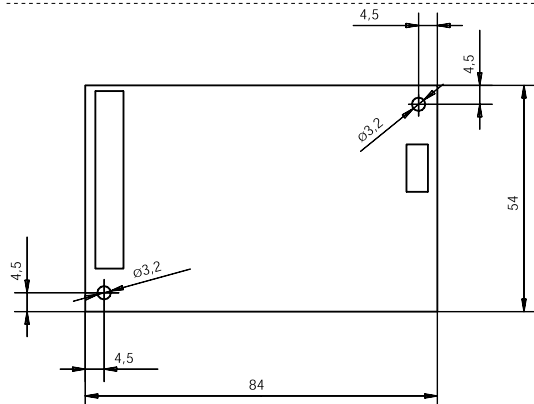

For latest technical and safety compliance information regarding these products, please download the relevant data sheet from our web site: [www.saia-burgess.com/drivers](http://www.saia-burgess.com/drivers)

All specifications are representative only and maybe subject to variation. For confirmation of values, please contact Johnson Electric. Please also read "Saia Motors Important Notes" on catalog or at [www.johnsonelectric.com/SaiaMotorsNotes](http://www.johnsonelectric.com/SaiaMotorsNotes)

# Evaluation-Kit 2

## Evaluation-Kit 2

Driver	for unipolar and bipolar motors
Dimensions (mm)	metal case 164 x 130 x 45
Motor voltage (VDC)	3-48 Unipolar motors
(VAC)	8-48 Bipolar motors (< 8 on request)
Motor current	constant voltage drive and constant current drive (chopper controlled)
Step mode	full/half/micro step
Clock source	internal, programmable
Control inputs to	<ul style="list-style-type: none"><li>■ 3 digital inputs</li><li>■ 4 signal outputs</li><li>■ 1 analog input 0...10 VDC</li><li>■ relay contact</li></ul>
Configuration	RS 232, USB



## Order Reference

4 717 4898 0

Power supply (on request)

## Technical Data

Supply voltage	10-48 VDC/24 VAC
Phase current	≤ up to 2.3 A
Step modes	11 (full, half, wave ... microstep)
Max. step frequency	10 kHz
PLC	max. 256 steps, 65536 loops
Operating temperature	0 ... +55 °C
Storage temperature	-20 to +80 °C

Test the Stepconf software without hardware in a special demo mode ([www.saia-burgess.com/evaluationkit2](http://www.saia-burgess.com/evaluationkit2)).

For further information please contact your Saia-Burgess sales company or see our website [www.saia-burgess.com](http://www.saia-burgess.com).

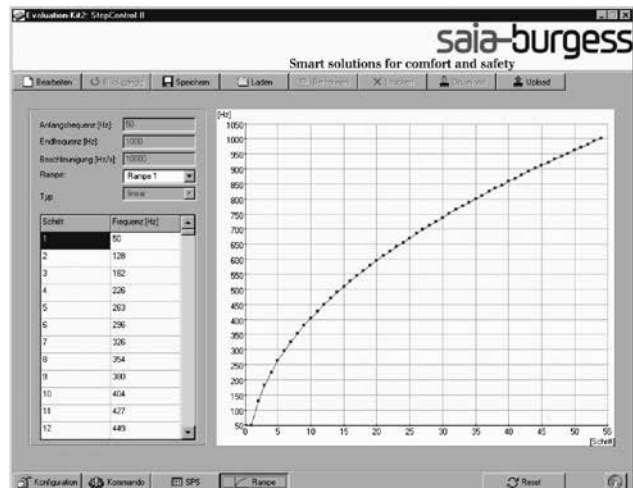

All specifications are representative only and maybe subject to variation. For confirmation of values, please contact Johnson Electric. Please also read "Saia Motors Important Notes" on catalog or at [www.johnsonelectric.com/SaiaMotorsNotes](http://www.johnsonelectric.com/SaiaMotorsNotes)

## Headquarters

6/F, 12 Science Park East Avenue,  
Hong Kong Science Park  
Shatin, NT, Hong Kong  
Phone: +852 2663 6688  
e-mail: sales@johnsonelectric.com

## Sales Offices (IPG)

### Asia

#### China

No. 1, Lane 10800, Songze Avenue,  
Qingpu Industrial Zone  
**Shanghai** 201700  
Phone: +86 21 6922 8256

Xin Er Industrial Zone  
Shajing Town, Baoan District  
**Shenzhen** 518125  
Phone: +86 755 2990 0437

#### Japan

Yaesu Dai Bldg., 6F  
1-1-1 Kyobashi, Chuo-ku,  
**Tokyo** 104-0031  
Phone: +81-3 3242 3830

#### Singapore

20 Harbour Drive #02-02  
PSA Vista  
**Singapore** 117612  
Phone: +65 6224 7570

#### South Korea

Fine Building, 4th Floor,  
304 Sinbanpo-ro, Seocho-Ku  
**Seoul** 137-808  
Phone: +82 2 518 8347

### Europe

#### Germany

Auf der Löbke 10  
58553 **Halver**  
Phone: +49 2353 911 0

#### Italy

Via Cadamosto 3  
20094 **Corsico**, Milano  
Phone: +39 02 4869 21

#### Switzerland

Freiburgstrasse 33  
3280 **Murten**  
Phone: +41 26 672 71 11

#### United Kingdom

Unit 5, Woodstock Way,  
Baldon Business Park, **Baldon**  
Tyne & Wear, NE35 9PF  
Phone: +44 844 811 2130

### Americas

#### USA

10 Progress Drive  
**Shelton**, CT 06484  
Phone: +1 203 447 5362

801 Scholz Drive  
P.O. Box 427  
**Vandalia**, OH 45377  
Phone: +1 937 454 2363

#### Brazil

Av. Papa Joao Paulo I - 1174  
Guarulhos, CEP 07170-350  
**Sao Paulo**  
Phone: +55 11 2431 5600

**Johnson Electric Group**

6/F, 12 Science Park East Avenue,

Hong Kong Science Park

Shatin, NT, Hong Kong

Phone: +852 2663 6688

[sales@johnsonelectric.com](mailto:sales@johnsonelectric.com)

[www.johnsonelectric.com](http://www.johnsonelectric.com)