



ENAPART



93 S Railroad Avenue Unit C
Bergenfield NJ 07621 USA
www.enapart.com
sales@enapart.com



Via del Canneto 35,
Borgosatollo, Brescia - Italia
www.enapart.it
vendite@enapart.it



Barbaros Mah. Ihlamur Bul. Aĝaoĝlu
My Newwork No:3/15 Ataşehir / İstanbul
www.enapart.net
satis@enapart.net



PRIVADA 10 B SUR #3908 COL.
ANZUREZ, C.P. 72530, PUEBLA, PUE
www.enapart.com.mx
sales@enapart.com.mx



Friedrich-Ebert-Anlage 36, 60325
Frankfurt am Main, Germany
www.enapart.de
anfrage@enapart.de



4 boulevard Carnot, 95400
villiers-le-bel, Paris, France
www.enapart.fr
sales@enapart.fr



65049, ОДЕСА, ВУЛИЦЯ ІВАНА
ФРАНКА, БУДИНОК 55, ПОВЕРХ 3
www.enapart.com.ua
sales@enapart.com.ua



MUNICIPIUL BUCUREȘTI, SECTOR 3,
B-DUL BASARABIA, NR.250, CORP P+5
www.enapart.ro
sales@enapart.ro



〒584-0023 大阪府富田林市若松町
東2丁目2番16号
www.enapart.co.jp
sales@enapart.co.jp



PLAZA NUESTRA SEÑORA DE LAS
NIEVES 12 ,LOCAL ,50012,ZARAGOZA
www.enapart.es
ventas@enapart.es



Складова база „Онгъл“, Склад А2, п.к.
4006, гр. Пловдив, България
www.enapart.bg
sales@enapart.bg



3 Austin Mews, High Street, Hemel
Hempstead, HP1 3AF , United Kingdom
www.enapart.co.uk
sales@enapart.co.uk

OVERHEAD PRIMARY TAPS HOT LINE TAP CLAMPS ALUMINUM

ALUMINUM
AH/S1500

- For Aluminum and ACSR conductor.
- Designed for standard "hot stick" application.

Material: **Body and Keeper** - Aluminum Alloy
Eyebolt - Bronze Alloy - Tin Plated
Eyestem - Bronze Alloy, Forged or Stainless Steel
Spring (on eyestem) - Stainless Steel

For Factory greased and bagged clamps, see notes below table.

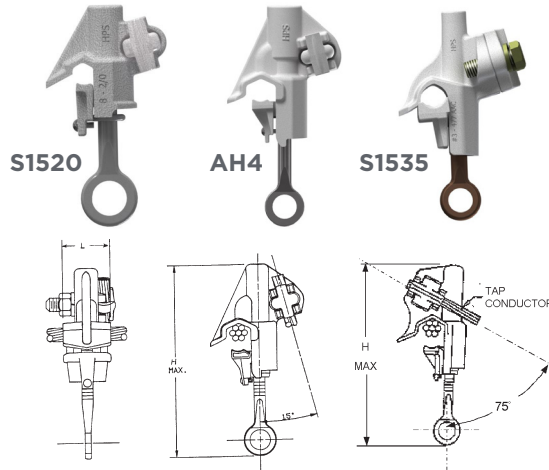

FIGURE 1

FIGURE 2

DC
1

Product Data & Conductor Size

CATALOG NUMBER	MAIN LINE	TAP	FIG. NO.	PLATING	CONDUCTOR RANGE (AWG OR KCMIL)						DIMENSIONS INCHES (MM)		TAP NUT (ACROSS FLATS)	AP-PROX. WT. EACH LBS. (KG.)
					MAIN			TAP			L	H		
					AAC	ACSR		AAC/CU	ACSR					
*S1520AA	AL	AL	1	None	#8 - 2/0 Str.	n/a	#8 - 1/0	n/a	#8 Sol. - 2/0 Str.	#8 - 1/0	1.0 (25.4)	5.25 (133)	9/16 (14.3)	0.4 (0.18)
*S1520AGP	AL	AL/CU		Tin plated	---0.128 - 0.414--- (3.25 - 10.54)									
AH4** (#)	AL	AL	1	None	#6 Sol. - 600	#6 Str. - 3/0 Str.	#8 - 556.5 (18/1)	#6 - 3/0	#6 Sol. - 266.8	#8 - 4/0	1.75 (44)	7.75 (196)	9/16 (14.3)	0.8 (0.36)
AH4GP** (#)	AL	AL/CU		Tin plated	---0.157 - 0.905 --- (4.00 - 23.03)									
*S1530AA (#)	AL	AL	2	None	#6 Sol. - 400	#6 Str. - 2/0 Str.	#6 - 397.5 (18/1)	#4 - 1/0	#6 Sol. - 4/0 Str.	#6 - 3/0	1.75 (44)	7.13 (181)	11/16 (17.5)	0.64 (0.29)
*S1530AC (#)	AL	CU		AC Trans+	---0.162 - 0.745 --- (4.12 - 18.96)									
*S1530AGP	AL	AL/CU		Tin plated	---0.162 - 0.547--- (4.12 - 13.92)									
*S1534AGP	AL	AL/CU		Tin plated										
*S1535AA	AL	AL	3	None	#3 Str. - 477	#4 - 3/0 Str.	#4 - 397.5	#4 - 2/0	#4 Str. - 477	#8 - 397.5	1.50 (38)	7.75 (196)	3/4 (19)	0.88 (0.40)
*S1535AGP	AL	AL/CU		Tin plated	---0.250 - 0.806 --- (6.36 - 20.51)									
*S1540AC (#)	AL	CU	2	AC Trans+	4/0 Str. - 800	#4 Str. - 4/0	3/0 (6/1) - 636 (30/19)	#4 - 266.8	#4 Sol. - 350	#6 - 266.8	1.81 (46)	7.31 (186)	3/4 (19)	0.98 (0.45)
*S1540AGP	AL	AL/CU		Tin plated	---0.502 - 1.031 --- (12.78 - 26.24)									
AH7** (#)	AL	AL	2	None	4/0 Str. - 800	#4 Str. - 4/0	3/0 (6/1) - 636 (30/19)	#4 - 266.8	#4 Sol. - 350	#6 - 266.8	1.81 (46)	7.31 (186)	3/4 (19)	0.98 (0.45)
AH7GP** (#)	AL	AL/CU		Tin plated	---0.502 - 1.031 --- (12.78 - 26.24)									
*S1545AA	AL	AL	2	None	700 Str. - 1500	266.8 - 715.5	556.5 (30/7) - 1510 45/7	266.8 - 556.5	#4 Sol. - 300	#6 - 266.8	2.19 (56)	9.63 (245)	3/4 (19)	1.35 (0.61)
*S1545AGP	AL	AL/CU		Tin plated	---0.939 - 1.490 --- (23.90 - 37.92)									

* Replace Prefix "S" with "P" for factory greased and bagged part (i.e. P1534AGP).

**Add "XB" Suffix for factory greased and bagged part (i.e. AH7GPXB).

#RUS Listed

+ Aluminum/Copper bimetallic washer in eyebolt.



OVERHEAD PRIMARY TAPS HOT LINE CONNECTORS ALUMINUM

ALUMINUM
GA100

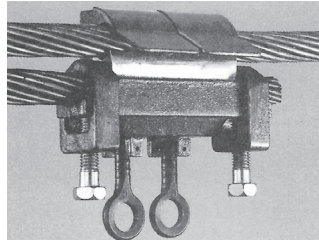
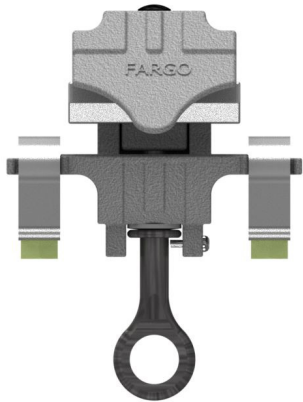

For Aluminum and ACSR conductor.

Designed for standard "hot stick" application.

- May be used for all standard hot line tap connections as well as full duty connections involving major line equipment and apparatus or main to main line joints
- Can be used for bimetal connections (Aluminum run to copper tap) with standard Fargolene inhibitor

Material: **Body and Keeper** - Aluminum Alloy
Spacer - Pure Soft Aluminum
Eyestem - Aluminum Alloy, Forged
Spring (on eyestem) - Stainless Steel Belleville

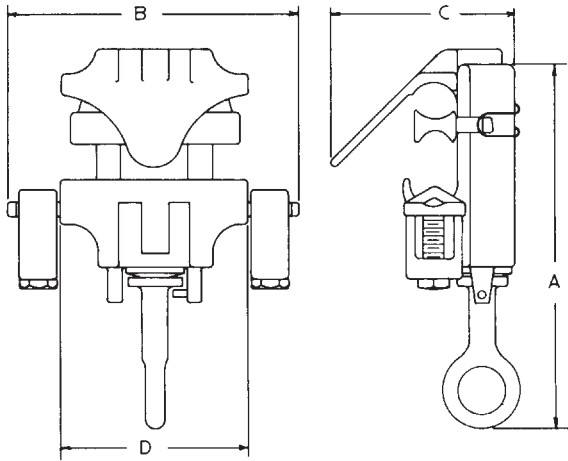

DC
2

Product Data & Conductor Size

CATA- LOG NUM- BER	CONDUCTOR SIZE								APPROX. DIMENSIONS INCHES				APPROX. WT. EACH LBS. (KG).
	RUN				TAP				A	B	C	D	
	MAX.		MIN.		MAX.		MIN.						
	ACSR	AL.	ACSR	AL.	ACSR	AL. OR CU.	ACSR	AL. OR CU.					
GA102L	1/0	2/0 Str.	6	6 Sol.	1/0	2/0 Str.	6	6 Sol.	5	3-7/8	2-1/4	2-1/8	.6 (.27)
GA103L	4/0	4/0 Str.	4	4 Sol.	4/0	4/0 Str.	4	4 Sol.	5-3/4	4-1/2	2-3/4	2-1/2	.88 (.39)
GA104L	4/0	4/0 Str.	4	2 Sol.	2/0	2/0 Str.	6	6 Sol.	5-3/4	4-1/2	2-3/4	2-1/2	.89 (.40)
GA105L	336,400	397,500	3/0	4/0 Str.	336,400	397,500	3/0	4/0 Str.	6	4-5/8	3	2-7/8	.96 (.43)
GA106L	397,500	477,000	3/0	4/0 Str.	4/0	266,800	6	6 Sol.	6	4-5/8	3	2-7/8	.96 (.43)
GA1064L	336,400	397,500	2	1 Str.	2/0	2/0 Str.	4	2 Sol.	6	4-5/8	3	2-7/8	.96 (.43)
GA107L	666,600	800,000	4/0	266,800	4/0	4/0 Str.	2	1 Str.	6-1/2	4-3/4	3-1/2	3-1/4	1.16 (.53)
GA1074L	477,000	636,000	266,800	336,400	336,400	350,000	4	2 Sol.	6-1/2	4-3/4	3-1/2	3-1/4	1.16 (.53)
GA108L	666,600	800,000	4/0	266,800	2/0	2/0 Str.	6	6 Sol.	6-1/2	4-3/4	3-1/2	3-1/4	1.18 (.54)
Two Bolt Hot Line Connector													
GA113L	477,000	600,000	4/0	4/0	477,000	600,000	4/0	4/0	6-1/2	5-7/8	3-1/2	4	2.25 (1.02)
GA115L	636,000	800,000	336,400	350,000	636,000	800,000	336,400	350,000	8-1/8	7-3/8	2-1/2	5-1/4	3.8 (1.7)



OVERHEAD PRIMARY TAPS HOT LINE TAP CLAMPS ALUMINUM

ALUMINUM
GH100A

For Aluminum and ACSR conductor.

Designed for standard "hot stick" application.

Material: **Body and Keeper** - Aluminum Alloy
Eyebolt - Bronze - Tin Plated
Eyestem - Aluminum, Forged
Spring (on eyestem) - Stainless Steel

Note: Add "C" suffix for bi-metal washer to eye bolt, ex. GH102AC
Add "L" suffix for factory loaded inhibitor in main conductor groove, ex. GH102AL
Add "LBE" suffix for factory loaded inhibitor in main conductor and tap eyebolt, ex. GH102ALBE

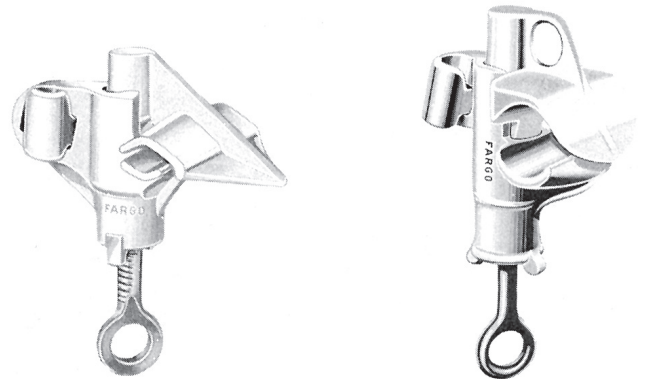

GH102A

GH103A

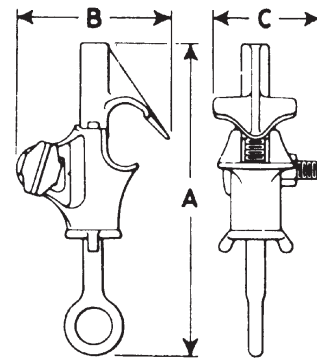

DC
3

Product Data & Conductor Size

CATALOG NUMBER	TYPE CONNECTION		RUN CONDUCTOR SIZE			TAP CONDUCTOR SIZE			APPROX. DIMENSIONS INCHES		
	RUN	TAP	DIA. IN.	MAX.	MIN.	DIA. IN.	MAX.	MIN.	A	B	C
GH102A** *GH102AC**	Al.	Al/Cu.	1.075 to	795	4/0 Str.	.610 to .152	250	6 Sol.	7-1/4	4-3/8	2-5/8
		Cu.	.490	Al.	Al.						
GH103A *GH103AC	Al.	Al/Cu.	1.795 to	2,000	666.6	.610 to .152	250	6 Sol.	9	4-1/2	2-5/8
		Cu.	.980	Al.	ACSR						

Note: All above have aluminum body, forged aluminum eye bolt and plated bronze tap bolt, except, GH103A have cast bronze eye stem.

*All "AC" clamps have a bimetal spacer on tap bolt. For use with copper tap conductor.

**RUS Listed



OVERHEAD PRIMARY TAPS HOT LINE TAP CLAMPS HOT LINE TAPS FOR MOUNTING CURRENT LIMITING FUSES ALUMINUM

ALUM/BRONZE
GH200A

DC
4



GH201 Series Hot Line Taps are specifically designed to mount current limiting fuses directly on the line conductor eliminating the need for increased pole height to maintain adequate clearances.

- Fuse replacement can be readily accomplished using standard hot stick techniques
- Accommodates either spade or pin terminals of current limiting fuses as well as conventional solid or stranded tap conductors
- Tap position is located to provide adequate room for installation tools as well as vertical fuse alignment. Permanent contact pressure is maintained by the use of a heavy duty stainless steel Belleville spring. Long "duck-bill" provides a guide for easy initial contact with run conductor
- Forged eyebolts provide consistent strength and uniform expansion under loading conditions

Material: **Body and Keeper 201** – Bronze
Body and Keeper 201A – Aluminum Alloy
Eyebolt – Bronze – Tin Plated
Eyestem – Bronze Alloy, Forged
Spring (on eyestem) – Stainless Steel Belleville

Note: Add "L" suffix for factory loaded inhibitor in main conductor groove, ex. GH201AL
 Add "LBE" suffix for factory loaded inhibitor in main conductor and tap eyebolt, ex GH201ALBE

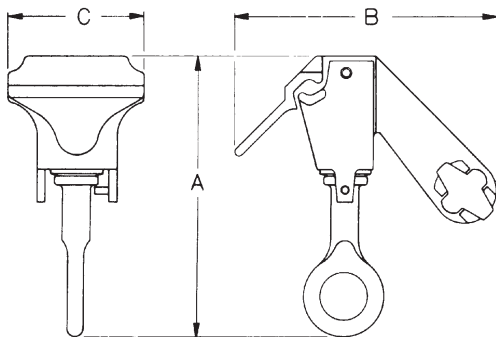

Product Data & Conductor Size

BRONZE

CATALOG NUMBER	RANGE		APPROX. DIMENSIONS INCHES			AP-PROX. WT. EACH LBS. (KG.)
	RUN	TAP	A	B	C	
GH201L**	#4 Str. - 2/0 Str. Copper	#6 Sol.-2/0 Str. Or C.L. Fuse Spade/Pin Terminal	4-1/4	4-1/8	1-3/4	.82 (.37)

ALUMINUM

GH202AL	795-4/0 AL	#8 Sol. - 2/0 Str. Or C.L. Fuse Spade/Pin Terminal	5-1/4	5-1/2	3	.80 (.36)
---------	------------	--	-------	-------	---	-----------

**RUS Listed

OVERHEAD PRIMARY TAPS AND STIRRUP POSTS ADDITIONAL ACCESSORIES ALUMINUM AND BRONZE

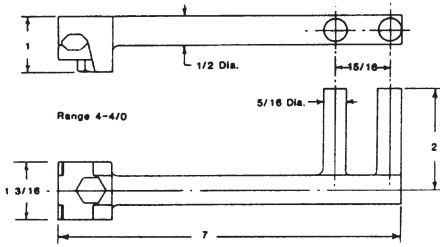

CE14
CE14 (Bronze)



GH280CX (BRONZE)

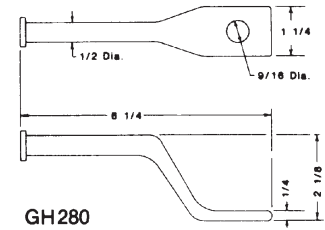

GH280

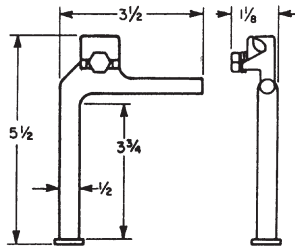

J3LS2 (Bronze)



GH282, GH284 AND GH286 (COPPER)

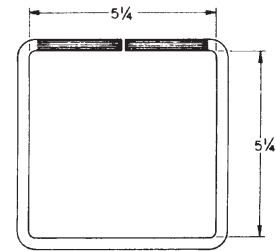

GH282 1/4" Dia. Copper Rod
GH284 5/16" Dia. Copper Rod
GH286 3/8" Dia. Copper Rod

STIRRUP POSTS

Fargo stirrups are designed for ease of attachment of hot line taps or bypass clamps on various system components.

The use of stirrups protect the run conductor, and provide positive contact for hot line taps, recloser connections, and "pig tails."

These stirrups are applied on products such as cut-outs, riser pole disconnect switches and pad mounted switch gear and temporary-only for maintenance purposes, not for safety grounding applications.

Cast from high strength aluminum or bronze the stirrup rod readily accepts standard hot line connectors or ground clamps. The shoulder "button" on the end prevents the clamps or connectors from slipping off during installation.

Where applicable, stirrup holes permit application on spades or terminals with Standard NEMA Spacing.

For Tin-Plated Bronze Stirrups add Suffix "P."

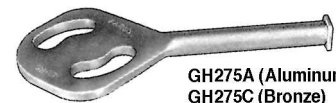

GH275A (Aluminum)
GH275C (Bronze)

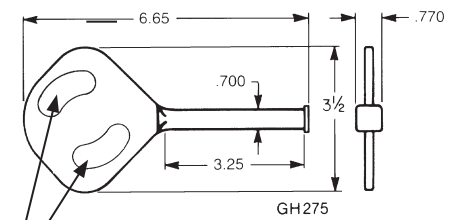

Holes at 1-3/4" NEMA spacing

Not designed for Fault Current

* For 5.25" post length add 525 suffix



OVERHEAD PRIMARY TAPS HOT LINE TAP CLAMPS BRONZE

BRONZE
BC/BH

DC
6



FIGURE 1 FIGURE 1A FIGURE 2 FIGURE 3

For Copper conductor.

Designed for standard "hot stick" application.

Material: **Body and Keeper** - BC/BH—Brass Alloy
BC/BH—FTP—Brass Alloy
— Tin Plated

Eyebolt - Bronze Alloy

Eyestem - Bronze Alloy or Stainless Steel

Washer - BH—Silicon Bronze
BC/BH—FTP—Stainless Steel

1. BC20LD has a longer "DUCKBILL" for easier attachment to a stirrup bail or conductor.
2. For connector with inhibitor in main jaw and plastic bag, add suffix "XB" to catalog number.

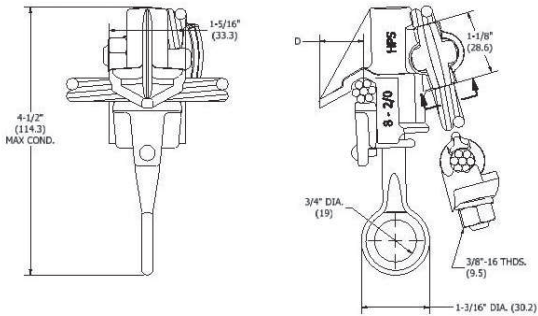

FIGURE 1 & 1A (BC & BC-LD)

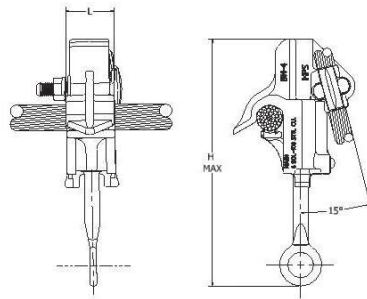

FIGURE 2 (BH)

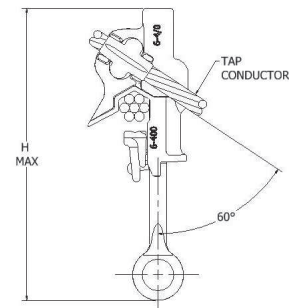

FIGURE 3 (S1530CC/S1540CC)

Product Data & Conductor Size

CATALOG NUMBER	MAIN LINE	TAP	FIG. NO.	PLATING	PACKAGING	CONDUCTOR RANGE (AWG OR KCMIL)		DIMENSIONS INCHES (MM)			AP-PROX. WT. EACH LBS. (KG).						
						MAIN	TAP	D	L	H							
BC20**	CU	CU	1	None	Box	#8 Sol - 2/0 Str. .128" - .419" (3.25 - 10.64)	#8 Sol - 2/0 Str. .128" - .414" (3.25 - 10.51)	.78 (19.81)	1-1/4 (31.7)	5.0 (127.0)	0.7 (.32)						
BC20XB**	CU	CU		None	Inhib & Bag												
BC20FTP	CU	CU		Tin plated	Box												
BC20FTPXB	CU	CU		Tin plated	Inhib & Bag												
BC20LD	CU	CU	1A	None	Box												
BC20LDXB	CU	CU		None	Inhib & Bag												
BC20LDFTP	CU	CU		Tin Plated	Box												
BC20LDFTPXB	CU	CU		Tin Plated	Inhib & Bag												
BH4	CU	CU	2	None	Box	#6 Sol - 400mcm .162" - .745" (4.12 - 18.96)	#6 Sol - 4/0 Str. .162" - .547" (4.12 - 13.89)	-	1-3/8 (34.92)	6-3/4 (171.45)	1.71 (.78)						
BH4XB	CU	CU		None	Inhib & Bag												
BH4FTP	CU	CU		Tin plated	Box												
BH4FTPXB	CU	CU		Tin plated	Inhib & Bag												
*S1530CC	CU	CU	3	None	Box							#6 Sol - 400mcm .162" - .745" (4.12 - 18.96)	#6 Sol - 4/0 Str. .162" - .547" (4.12 - 13.89)	-	1-3/8 (34.92)	6-3/4 (171.45)	1.59 (.72)
*S1530GP	CU	CU		Tin plated	Box												
*S1540CC	CU	CU		None	Box												
*S1540GP	CU	CU		Tin plated	Box												
						4/0 Str. - 800mcm .502" - 1.031" (12.78 - 26.24)	#4 Sol - 350mcm .198" - .703" (5.04 - 17.98)		1-7/8 (48)	8-1/4 (210)	2.03 (.92)						

*For factory grease, replace "S" prefix with "P".

**RUS Listed

OVERHEAD PRIMARY TAPS LIGHTNING ARRESTER ACCESSORIES ALUMINUM AND BRONZE

ALUM/BRONZE
GH200/GO370

The arrester line connectors allow installation of lightning arrester directly on the line, which conserves pole space and the cost of mounting hardware.

- GH201D (bronze) and GH202AD (aluminum) versions are designed to accommodate the stud of the arrester in the rear extension of the connector.
- GO370 series Bronze Arrester Connectors thread onto the stud of an arrester. Side loading feature provides flexibility in application. Hot stick feature allows for change out of an arrester without interruption of service.
- This connector is intended primarily for bottom termination of lightning arresters to ground. May also be employed on top connections.
- GS580 Wildlife Protector is designed to be mounted on the top of a lightning arrester, and accommodates any of the GO370 series arrester connections. Hinged design allows easy access to connector. Track resistant polypropylene with ultraviolet inhibitors.

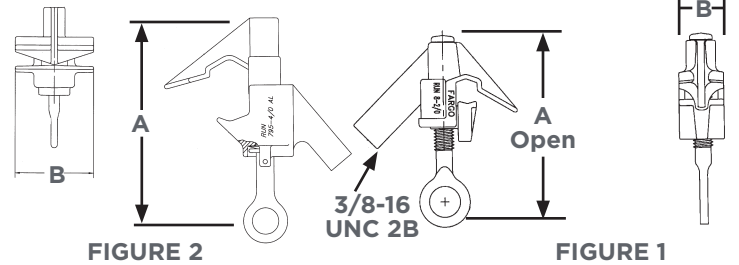
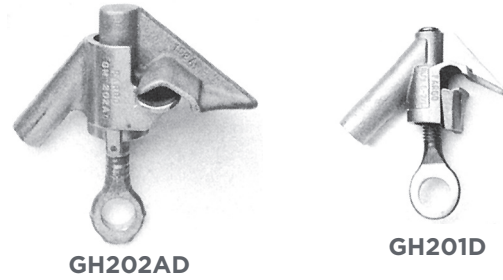

Material: Body and Keeper GH201D & GO300 Series - Bronze
Body and Keeper 202AD - Aluminum Alloy
Eyestem 201D - Bronze Alloy, Forged
Eyestem 202AD - Aluminum Alloy, Forged
Spring (on eyestem) - Stainless Steel Belleville

Note: Add "P" suffix for tin plating, ex GH201DP
Add "L" suffix for factory loaded inhibitor in main conductor groove, ex. GH201DPL

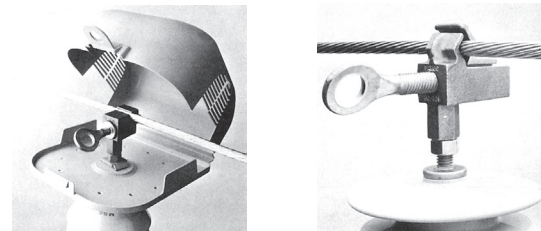

GO370 SERIES

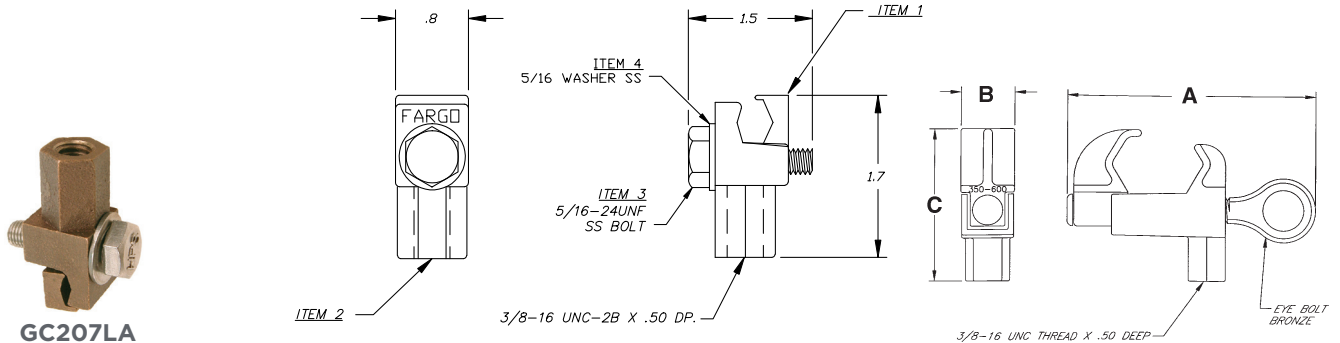

See also: Page DD-10 GC207LA & LAT

Product Data & Conductor Size

CATALOG NUMBER	MAIN LINE	FIG. NO.	PLATING	PACKAGING	CONDUCTOR RANGE		DIMENSIONS INCHES (MM)			APPROX. WT. EACH LBS. (KG.)
					COPPER	ALUMINUM	A	B	C	
GH201D	CU	1	None	Box	#8 Sol - 2/0 Str.	n/a	4 (102)	1 (25)	n/a	.74 (.34)
GH202AD	AL	2	None	Box	n/a	4/0 - 795 AAC	6.5 (165)	1.5 (38)	n/a	.72 (.33)
GH202ADL	AL/CU	2	None	Box	4/0 Str. - 750	.522 - 1.028	6.5 (165)	1.5 (38)	n/a	.72 (.33)
GO375	CU	3	None	Box	#6 - 1/0 Str	n/a	3.9 (99)	0.9 (23)	1.9 (48)	.48 (.22)
GO375P	CU	3	Tin plated	Box	.184 - .373		3.9 (99)	0.9 (23)	1.9 (48)	.50 (.23)
GO376	CU	3	None	Box	2/0 - 350 Str.		4.3 (109)	0.9 (23)	2.3 (59)	.59 (.27)
GO376P	CU	3	Tin plated	Box	.414 - .710		4.3 (109)	0.9 (23)	2.3 (59)	.60 (.27)
GC207LA	CU	4	None	Box	#6 Sol-1/0 Str.		1.25 (32)	0.75 (19)	1.77 (48)	.22 (.99)



OVERHEAD PRIMARY TAPS HOT LINE CONNECTORS TWO HOLE PAD BRONZE AND ALUMINUM

BRONZE
BHF/AHF

- Wide body contact area and two hole pad tap provide high current transfer for jumper or hot line clamp application.
- BHF - Bronze protected thread hot line clamp with two hole NEMA pad. Designed for copper main to copper flat pad tap.
- AHF - Aluminum protected thread hot line clamp with two hole NEMA pad. Designed for aluminum main to aluminum flat pad tap.

Material: Casting – BHF/GH1010 - Bronze Alloy
 BHF-FTP - Bronze Tin Plated
 AHF - Aluminum Alloy
 Spring (on eyestem) - Stainless Steel
 Eyestem - Bronze



FIGURE 1

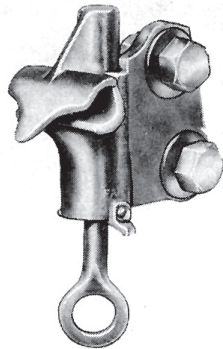

GH1010

FIGURE 2

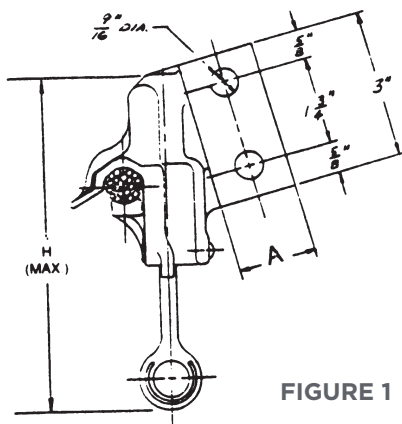

FIGURE 1

Product Data & Conductor Size

CATALOG NUMBER	FIG. NO.	CONDUCTOR RANGE (KCML)		DIMENSIONS INCHES (MM)			APPROX. WT. EACH LBS. (KG)
		MAIN	MATERIAL	A	MAIN CONTACT WIDTH	H	
BHF500B2	1	6 Sol. - 500 Str. CU .162" - .813"	Bronze	1.5 (36.75)	1.375 (35.0)	6.75 (171.4)	1.66 (.75)
GH1010	2	6 Sol - 400 CU .160 - .730	Bronze	-	1.375 (35.0)	5.125 (130.25)	1.52 (.69)



OVERHEAD PRIMARY TAPS STIRRUP CLAMPS ALUMINUM

ALUMINUM
AHLS

For aluminum or ACSR conductor.

Eyestem is at 30° angle from the stirrup.

Material: **Body** - Aluminum Alloy
Eyestem - Bronze Alloy—Tin Plated or Stainless Steel
Stirrup - Copper-un-plated

Notes: Tin plated stirrup available by adding suffix "TB" to catalog number. Examples, AHLS022016ETB, AHLS954022EWBTB

Factory inhibited and bagged, add "XB"

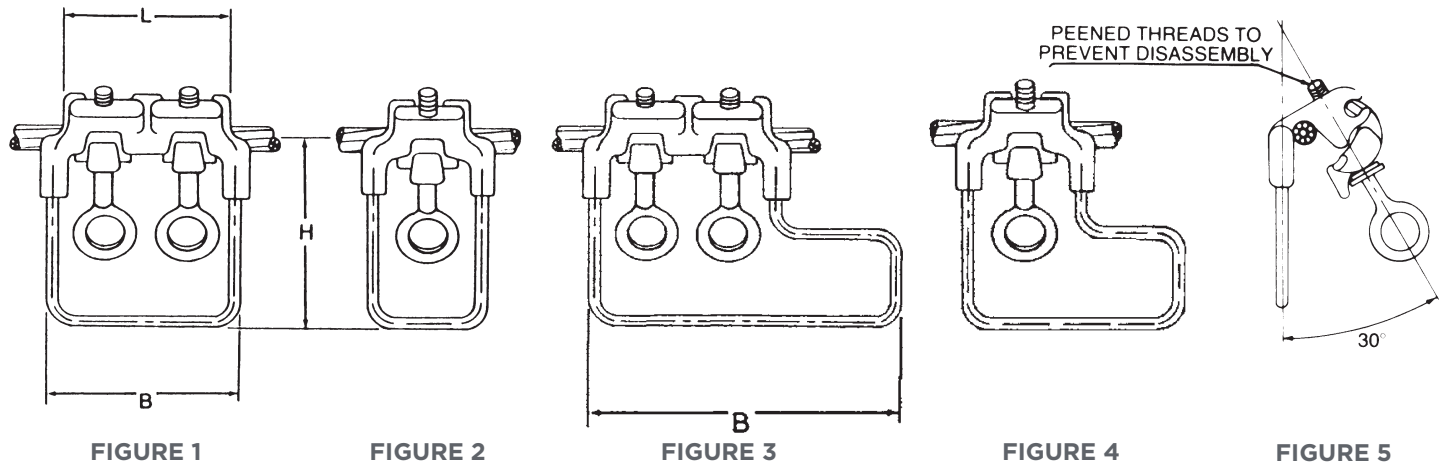
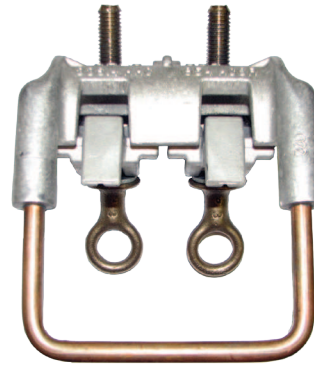

DC
9

Product Data & Conductor Size

CATALOG NUMBER	FIGURE NO.	CONDUCTOR RANGE (AWG OR MCM)		COPPER LOOP SIZE (INCHES)	BOLTS		DIMENSIONS INCHES (MM)			APPROX. WT. EACH LBS. (KG)
		AAC	ACSR		NO.	SIZE	L	B	H	
AHLS022016E	2 & 5	#6 Sol.-2/0 Str.	#8-2/0 Str.	#4 (.204)	1	3/8 (9.52)	1-13/16 (46.04)	2-3/8 (60.32)	4-1/32 (102.39)	.53 (.24)
AHLS022019E	2 & 5	#6 Sol.-2/0 Str.	#8-2/0 Str.	#1 (.289)	1	3/8 (9.52)	1-13/16 (46.04)	2-3/8 (60.32)	4-3/16 (106.36)	.67 (.30)
AHLS022019EWB	4 & 5							4-1/2 (114.3)	5-1/16 (128.59)	.71 (.32)
AHLS024019E	1 & 5	#2-4/0 Str.	#4-4/0 Str.	#1 (.289)	2	3/8 (9.52)	3-1/2 (88.9)	4 (101.6)	4-1/16 (103.19)	1.19 (.54)
AHLS024021E	1 & 5	#2-4/0 Str.	#4-4/0 Str.	1/0 (.325)	2	3/8 (9.52)	3-1/2 (88.9)	4 (101.6)	4-1/32 (103.19)	1.25 (.57)
AHLS024021EWB	3 & 5							6 (152.4)	4-29/32 (124.62)	1.29 (.59)
AHLS397021E	1 & 5	1/0-500 MCM	1/0-397.5 MCM	1/0 (.325)	2	7/16 (11.8)	3-11/16 (93.66)	4 (101.6)	4-3/32 (103.99)	1.56 (.71)
AHLS397022E	1 & 5	1/0-500 MCM	1/0-397.5 MCM	2/0 (.365)	2	7/16 (11.8)	3-11/16 (93.66)	4 (101.6)	4-3/32 (103.99)	1.65 (.75)
AHLS397022EWB	3 & 5							6 (152.4)	4-31/32 (126.21)	1.91 (.87)
AHLS954022E	1 & 5	336.4-1033.5 MCM	336.4-954 MCM	2/0 (.365)	2	1/2 (12.7)	4-1/4 (107.95)	4-1/2 (114.3)	4-3/16 (106.36)	2.30 (1.04)
AHLS954022EWB	3 & 5							6 (152.4)	5-1/16 (128.59)	2.41 (1.09)
AHLS954024E	1 & 5	336.4-1033.5 MCM	336.4-954 MCM	4/0 (.460)	2	1/2 (12.7)	4-1/4 (107.95)	4-1/2 (114.3)	4-3/16 (106.36)	2.49 (1.13)



OVERHEAD PRIMARY TAPS SPRING LOADED “LINE SNAPPER” STIRRUP CLAMPS ALUMINUM

ALUMINUM
ESC

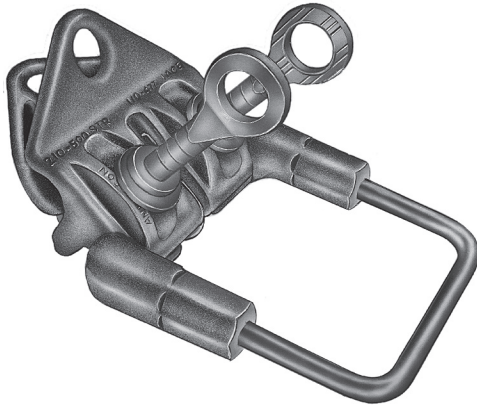

- Two bolt stirrups have clip type springs to apply moderate pressure on the jaws as they are pushed onto the line. This pressure is enough to allow the assembly to support its own weight on the line while one of the eystemes is snugged down.
- Lifting eyes are provided on both jaws and eystemes are standard.
- The angular relationship between stirrup and tightening bolts is an easy approach position for making installation leaving the stirrup hanging straight down.

Material: Castings - Aluminum Alloy
 Stirrups - Copper Rod-Tin Plated
 Eystemes - Bronze Alloy Tin Plated or Stainless Steel
 Spring - Stainless Steel

Note: Factory inhibited and bagged, add “XB”

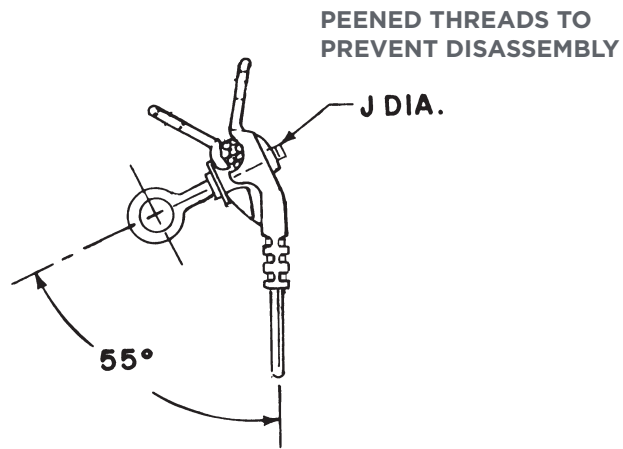
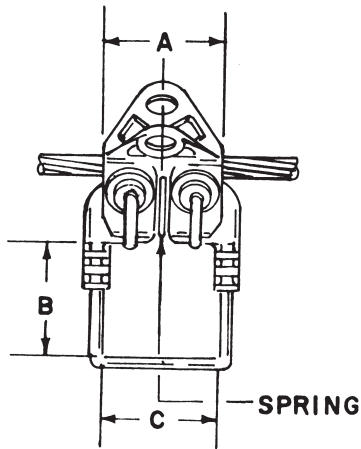

Product Data & Conductor Size

CATALOG NUMBER	MAIN CONDUCTOR RANGE	STIRRUP NOM. WIRE SIZE	DIMENSIONS INCHES (MM)				APPROX. WT. EACH LBS. (KG)
			A	B	C	J	
ESC202	6 Sol.-2/0 Str. #6 ACSR-2/0 ACSR .162"-.447" O.D.	2 Sol.	3-3/8 (85.8)	3-1/4 (82.5)	4 (101.6)	3/8 (9.6)	140 (63)
ESC50020	2/0 Str.-500 Str. 1/0 ACSR-477(18/1)ACSR .398"-.814" O.D.	2/0 Sol.	4 (101.6)	3-1/2 (88.9)	4-1/2 (114.3)	1/2 (12.7)	247 (112)

DC
10



OVERHEAD PRIMARY TAPS WIDE JAW STIRRUP CLAMPS ALUMINUM AND BRONZE

ALUM/BRONZE
HLSA/HLSB

- Heavy duty wide range stirrup clamp covers a broad cable range. One eyestem with long contact keeper provides easy installation.
- HLSA aluminum body designed for use on aluminum main.

Material: Castings - Aluminum Alloy
 Stirrup - Un-plated Copper
 Eyestem - Bronze Alloy Tin Plated

- HLSB bronze body designed for use on copper main.

Material: Castings - Bronze Alloy
 Stirrup - Un-plated Copper
 Eyestem - Bronze Alloy Tin Plated

Note: Factory inhibited and bagged, add "XB".

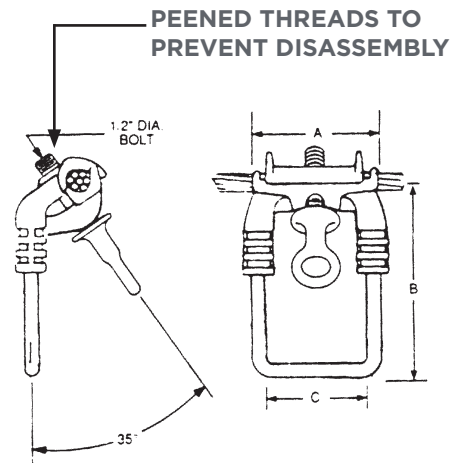

DC
11

Product Data & Conductor Size

CATALOG NUMBER	MAIN LINE CONDUCTOR RANGE	MATERIAL	STIRRUP NOM. WIRE SIZE	DIMENSIONS INCHES (MM)			APPROX. WT. 100 LBS. (KG)
				A	B	C	
HLSA4002	6 Sol. - 400 Str.	Aluminum	2 Sol. (.258)	3-1/8	3-3/8	2-3/4	116 (52)
HLSA40010	#6 ACSR - 397.5 (18/1) ACSR .162" - .743" O.D.		1/0 Sol. (.365)	(79.4)	(85.8)	(69.8)	136 (62)
HLSB4002	6 Sol. - 400 Str. Cu. .162" - .728" O.D.	Bronze	2 Sol. (.258)	3-1/8 (79.4)	3-3/8 (85.8)	2-3/4 (69.8)	220 (99.8)



OVERHEAD PRIMARY TAPS STIRRUP CONNECTOR ALUMINUM

ALUMINUM
GA100SL

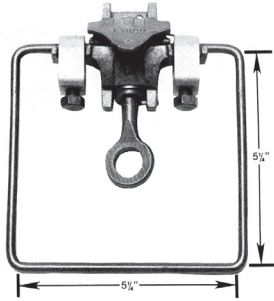

- GA100S Series Hot Line Stirrup Connector provides a convenient method to install tap connections which must be removed and re-installed frequently.
- Easily installed with standard Hot Stick equipment, and are recommended for uses on aluminum or ACSR run conductors in conjunction with a bronze hot line tap on the stirrup bail.
- Long term performance is assured by the field proven design incorporating, a large connector mass, vise-type interlocking components, and a short low resistance current transfer through a soft, pure aluminum spacer.
- The #2 Sol. hard drawn copper stirrup is positioned for adequate clearance. Additional stirrup sizes are available. Factory loaded with inhibitor

Material: Body Casting - Aluminum Alloy
Eyestem - Forged Aluminum

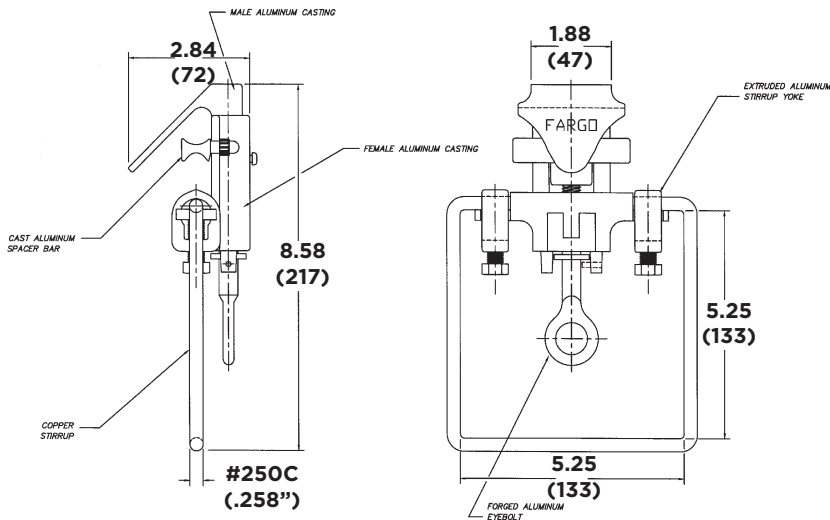

Product Data & Conductor Size

CATALOG NUMBER	COPPER LOOP SIZE IN (MM)	CONDUCTOR RANGE (AWG OR KCMIL)	APPROX. WT. EACH LBS. (KG)
GA102S*L	#2 Sol. (.258)	#6 Sol. - #2/0 ACSR	.96 (.44)
GA104S*L	#2 Sol. (.258)	#4 ACSR - #4/0 ACSR	1.24 (.56)
GA106S*L	#2 Sol. (.258)	#2/0 ACSR - 397.5 ACSR	1.32 (.60)
GA108S*L	#2 Sol. (.258)	#4/0 ACSR - 954 ACSR	1.44 (.65)

*For 2/0 Sol Stirrup Add Suffix "6" (e.g. GA108S6L)
For Plated Stirrup Add Suffix "P"
Suffix "L" indicates Inhibitor Protected as Standard.

DC
12



OVERHEAD PRIMARY TAPS STIRRUP CLAMPS ALUMINUM

ALUMINUM
GH280AL

GH280AL Series Aluminum Stirrup Clamps provide a convenient method of making copper connections and taps to ACSR, AAC and AAAC where connections are frequently installed and removed.

- Wide bail configuration provides easy installation for one or two hot-line taps.
- High-strength aluminum alloy body and pressure pad form permanent connection with low contact resistance.
- Forged aluminum eye bolt assures consistency of strength along with compatible thermal expansion/contraction characteristics and corrosion resistance.
- Serrated conductor groove prevents rotation on run conductor.
- Modified parabolic V-groove design encircles the run conductor maximizing contact area and ensuring efficient current transfer.
- Wrought aluminum alloy body provides elongation characteristics for consistent compression to copper stirrup.
- Crimped copper stirrup provides high conductivity to maintain low operating temperature.
- Meets or exceeds all ANSI-C119.4 Class A current cycle requirements.
- Factory inhibited and bagged



GH282AL

Material: **Body & Pad** - Extruded Aluminum
Stirrup - Copper
Eyestem - Forged Aluminum

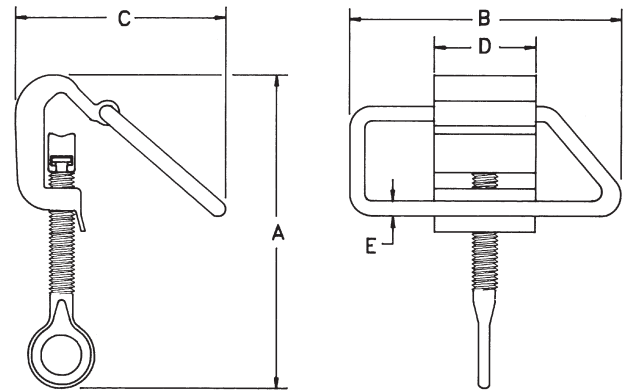

DC
13

Product Data & Conductor Size

CATALOG NUMBER	RANGE		APPROX. DIMENSIONS INCHES					APPROX. WT. EACH LBS. (KG)
	CONDUCTOR (AWG OR KCMIL)	O.D.	A	B	C	D	E	
GH282AL	4-4/0 ACSR	.250 - .563 in. 6.4 - 14.3 mm	5-1/4	4-1/2	3-1/2	1-3/4	1/4	.64(.29)
GH284AL	1/0 397.5 ACSR	.398 - .806 in. 10.1 - 20.5 mm	6	5-1/2	4	2-7/16	3/8	1.16(.53)
GH286AL	4/0 ACSR - 795 ACSR	.563 - 1.081 in. 14.3 - 27.4 mm	6-1/2	5-1/2	4-3/8	2-7/16	3/8	1.32(.60)



OVERHEAD PRIMARY TAPS BOLTED STIRRUP CLAMPS BRONZE

BRONZE
BHLS

For copper conductor.

Eyestem is at 30° angle from the stirrup.

Material: **Body** - Bronze Alloy
Stirrup - Copper-un-plated
Eyestem - Bronze alloy or Stainless Steel

Note: Tin plated loop available by adding suffix "TB" to catalog number. Example, BHLS025019ETB.

Factory inhibited and bagged, add "XB"

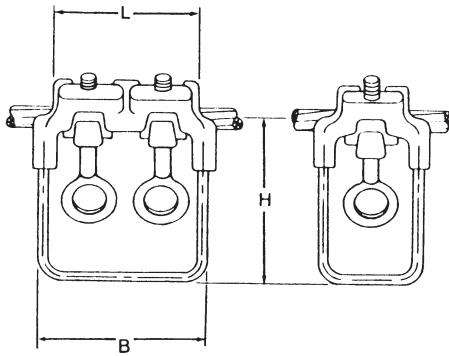
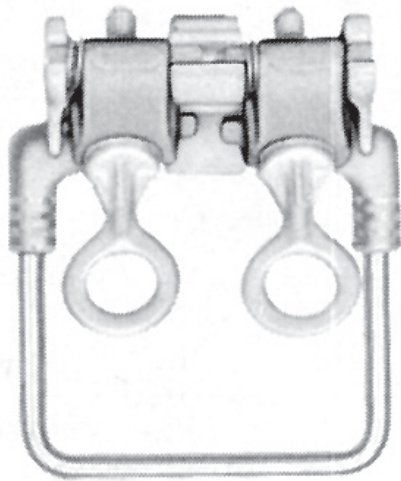
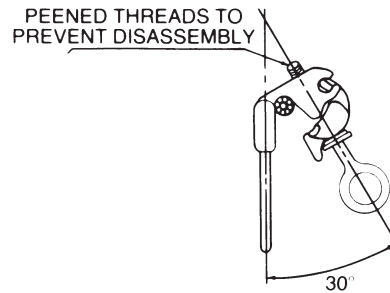

FIGURE 1

FIGURE 2



Product Data & Conductor Size

CATALOG NUMBER	FIGURE NO.	COPPER CONDUCTOR RANGE (AWG OR MCM)	COPPER LOOP SIZE	BOLTS		DIMENSIONS INCHES (MM)			APPROX. WT. 100 LBS. (KG)
				NO.	SIZE	L	B	H	
BHLS022016E	2 & 3	#6 Sol.-2/0 Str.	#4 (.204)	1	3/8 (9.52)	1-13/16 (46.04)	2-3/8 (60.32)	4-3/16 (106.36)	1.06 (.48)
BHLS022019E	2 & 3	#6 Sol.-2/0 Str.	#1 (.289)	1	3/8 (9.52)	1-13/16 (46.04)	2-3/8 (60.32)	4-3/16 (106.36)	1.06 (.48)
BHLS025019E	1 & 3	#1 Sol.-250 MCM	#1 (.289)	2	3/8 (9.52)	3-1/2 (88.9)	4 (101.6)	4-1/16 (103.19)	1.71 (.77)
BHLS050022E	1 & 3	4/0-500 MCM	2/0 (.365)	2	7/16 (11.2)	3-11/16 (93.66)	4 (101.6)	4-3/16 (106.36)	2.70 (1.22)



HEAVY DUTY COMPRESSION STIRRUP TYPE HLS

ALUMINUM
HLS

- For use with Versa-Crimp® or standard compression tools.
- Stirrups protect primary lines from arcing damage by allowing hot line clamp connections to be made without contacting the main line. The HLS design offers convenient installation because it can be lifted and placed on the line using the crimping tool jaws as a holding device.
- Wide stance of crimping segments gives good stability when striking bail with a hot line clamp. All sizes have side opening line slots.
- Stirrups can be used on either aluminum or copper lines. Contact grooves are prefilled with electrical joint compound. Individually packaged in poly bags to prevent contamination.

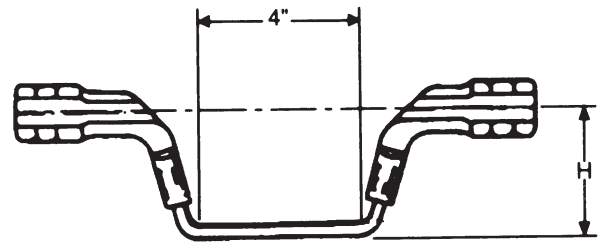
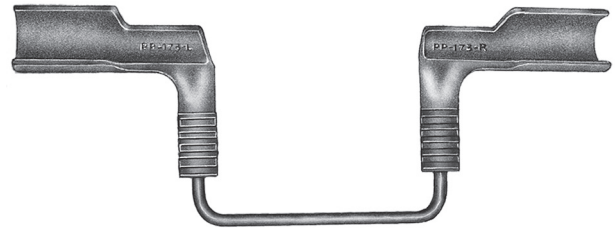

Material: Castings - Aluminum Alloy
Stirrup - Copper Rod—Tin Plated

DC
15

Product Data & Conductor Size

CATALOG NUMBER	CONDUCTOR RANGE (AL OR CU)			STIRRUP WIRE SIZE	CRIMP DIE SIZES	H INCHES (MM)	APPROX. WT. EACH LBS. (KG)
	AWG & KCMIL	ACSR	DIAMETER (INCHES)				
HLS42P	6 Sol.-4 Str.	6	.162-.236	2 Sol.	Burndy Kearney Etc. "O" Die	3.25 (82)	50 (22.7)
HLS22P	2 Sol.-2 Str.	4-2	.250-.325				
HLS102P	1/0 Str.	1-1/0	.355-.398				
HLS302P	2/0 & 3/0 Str.	2/0-3/0	.414-.517	2 Sol.	EEI-13A Burndy 316,655 & 705 Kearney 1-1/8	3.25 (82)	60 (27.2)
HLS2662P	4/0-266 Str.	4/0-266 18/1	.522-.609				
HLS3502P	336-350 Str.	266-26/7 336-18/1	.607-.721				
HLS35020P		336-26/7		2/0 Sol.	81 (36.7)		
HLS50010P	397.5-500 Str.	397.5-18/1 397.5-36/1	.720-.814	1/0 Sol.	Kearney 1-5/16	3.75 (95)	82 (37.2)
HLS50020P		477-18/1 477-36/1		2/0 Sol.			91 (41.3)
HLS65010P	500-650 Str.	477-18/1 556-18/1	.811-.930	1/0 Sol.	Kearney 1-1/2	3.75 (95)	95 (43.1)
HLS65020P		636-36/1		2/0 Sol.			105 (47.6)
HLS80010P	700-800 Str.	636-18/1	.930-1.040	1/0 Sol.	Kearney 1-1/2	3.75 (95)	92 (41.7)
HLS80020P		636-36/1 666.6-36/1		2/0 Sol.			102 (46.3)
HLS80040P		795-36/1		4/0 Sol.			122 (55.3)



VERSA-CRIMP® ALUMINUM COMPRESSION STIRRUP TAP TYPE VCLS

ALUMINUM
VCLS

- For use with VERSA-CRIMP® Type VC6 (all) tools only.

Material: **Body** - Aluminum Alloy
Stirrup - Un-plated Copper
 Factory inhibited (See notes below)

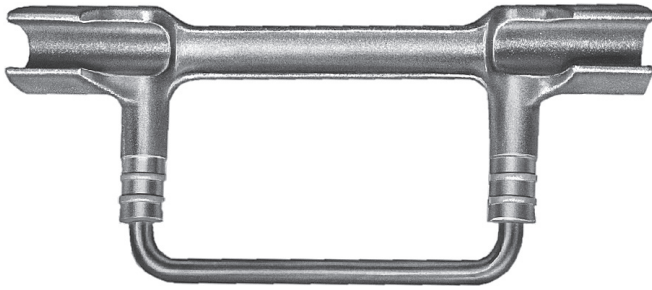
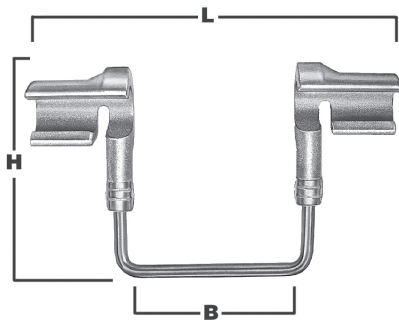

FIGURE 1



DC
16

Product Data & Conductor Size

CATALOG NUMBER	FIG-URE NO.	CONDUCTOR RANGE			LOOP SIZE	VERSA-CRIMP TOOL TYPE	DIMENSIONS INCHES (MM)			APPROX. WT. EACH LBS. (KG)
		AAC	ACSR	COPPER			L	B	H	
VCLS3018	1	#6 (7)—#2(19)	#6 (6/1)—#2 (7/1)	#6 Sol.-#2 (7)	#2 Sol.	VC6 (ALL)	8-5/8 (219.1)	4 (101.6)	3-7/16 (87.3)	.44 (.20)
*VCLS5018	1	#6 (7)—2/0 (19)	#6 (6/1)—2/0 (6/1)	—	#2 Sol.		7-7/8 (200.0)	4 (101.6)	3-7/16 (87.3)	.48 (.22)
*VCLS6021	1	#4 (7)—266.8 (19)	#4 (6/1)—4/0(6/1)	—	1/0 Sol.		8 (203.2)	4 (101.6)	3-1/2 (88.9)	.65 (.29)
VCLS9022	2	3/0 (7)—556.5 (19)	3/0 (6/1)—477 (30/7)	—	2/0 Sol.	VC6-3 VC6-FT	9-15/16 (252.41)	4-7/16 (112.7)	5-11/16 (144.5)	.80 (.36)

Note: Tin plated loop available by adding suffix "TB" to catalog number. Example, VCLS3018TB.

*For deep throated bail, add suffix "DB" to catalog number. Example, VCLS5018DB.



OVERHEAD PRIMARY TAPS COMPRESSION VERSA-CRIMP® COPPER COMPRESSION STIRRUP TAP COPPER

COPPER
VCLSC

- For use with VERSA-CRIMP® Type VC6 and VC7 series tools only.
- For copper conductor.

Material: **Body** - Cast Copper Alloy
Stirrup - Un-plated Copper

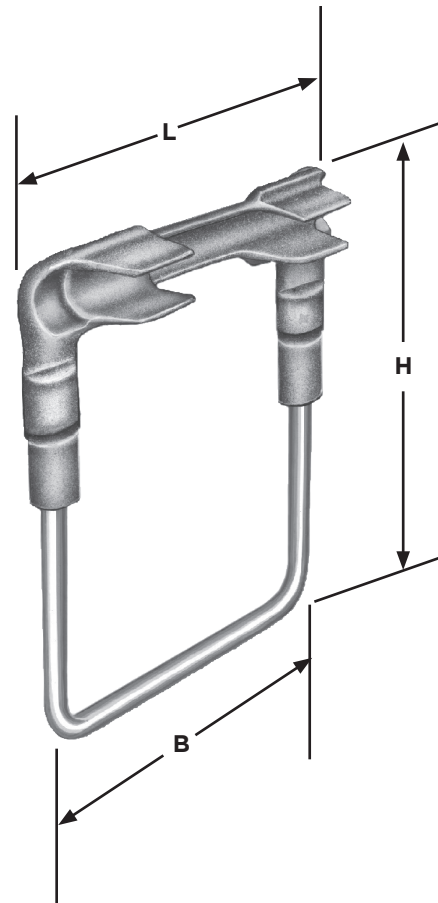

DC
17

Product Data & Conductor Size

CATALOG NUMBER	COPPER CONDUCTOR RANGE	LOOP SIZE	VERSA-CRIMP TOOL TYPE	DIMENSIONS INCHES (MM)			APPROX. WT. EACH LBS. (KG)
				L	B	H	
VCLSC3018	#6 Sol.-#2/(7)	#2 Sol. Cu.	VC7 VC6 (ALL)	5-1/2 (139.7)	5 (127.0)	5-11/32 (17.46)	.80 (.36)
VCLSC5021	#2 Sol.-2/0 (19)	1/0 Sol. Cu.		5-9/16 (141.3)	5 (127.0)	5-15/16 (150.81)	.96 (.44)
VCLSC6022	1/0 (7)-4/0(19)	2/0 Sol. Cu.		5-9/16 (141.3)	5 (127.0)	6-15/16 (176.21)	1.20 (.54)



VERSA-CRIMP[®] ALUMINUM COMPRESSION TAP

ALUMINUM
VCP

- For use with VERSA-CRIMP[®] Type VC6 (all) tools, except VC6350 and VC6500.
- For aluminum to aluminum or aluminum to copper conductor taps.
- For AAC or ACSR loop deadending on slack span construction when installed in tandem.

Material: Body - Aluminum Alloy
 Factory inhibited and packaged in individual boxes.

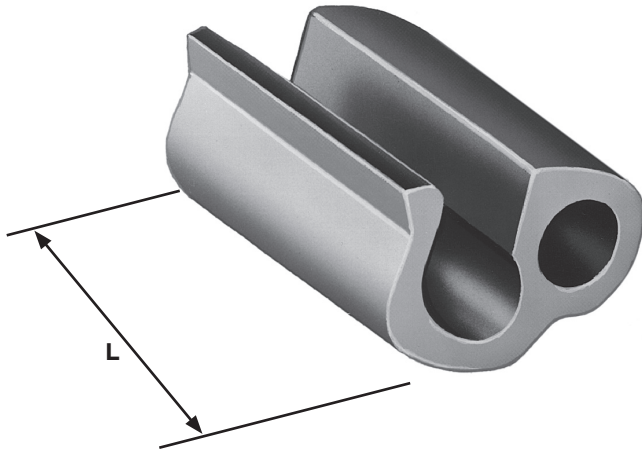

DC
18

Product Data & Conductor Size

CATALOG NUMBER	CONDUCTOR RANGE (AWG)						VERSA-CRIMP TOOL TYPE	LENGTH INCHES (MM)	APPROX. WT. EACH LBS. (KG)
	MAIN			TAP					
	AAC	ACSR	COPPER	AAC	ACSR	COPPER			
VCP44	2/0 (19, 7)	1/0 (6/1)		1/0 (19,7)	1/0 (6/1)		VC6 (ALL) ΔΔ	1-7/8 (47.6)	.10 (.05)
	1/0 (19, 7)	#1 (6/1)	#2 (7/1)	#1 (19,7)	#1 (6/1)	#2 (7, 1)			
	#1 (19, 7)	#2 (7/1, 6/1)	#4 (7/1)	#2 (19,7)	#2 (7/1, 6/1)	#4 (7, 1)			
	#2 (19, 7)	#4 (7/1, 6/1)	#6 (7/1)	#3 (7)	#4 (7/1, 6/1)	#6 (7, 1)			
	#3 (7), #4 (7)	#6 (6/1)		#4 (7)	#6 (6/1)				
	#6 (7)			#6 (7)					

ΔΔ For use with all VERSA-CRIMP Type VC6 four (4) nib tool only.

VERSAtile™ ALUMINUM COMPRESSION TEE



ALUMINUM
VACT

- For use with VERSA-CRIMP® or conventional tooling.
- For aluminum to aluminum or aluminum to copper conductor tee combinations.
- Uses the same installation tools and dies as VACS and VACL.
- Color coded end plugs for easy die selection.

Material: Aluminum Alloy – Tin Plated
Factory inhibited

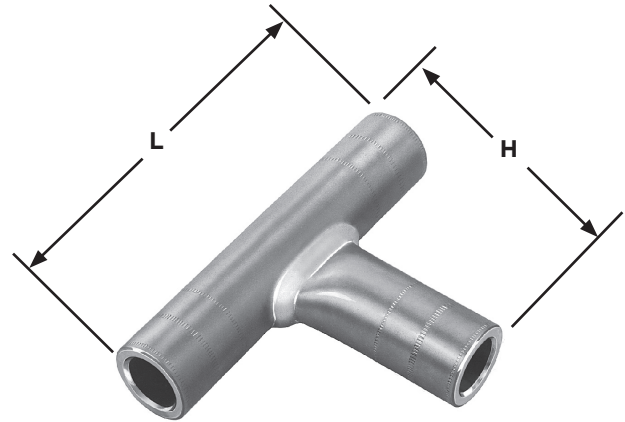

DC
19

AL9CU (90°C Rated) LISTED 261L

Product Data & Conductor Size

CATALOG NUMBER	ALUMINUM OR COPPER CONDUCTOR				VERSA-CRIMP TOOL TYPE	DIMENSIONS INCHES (MM)		APPROX. WT. EACH LBS. (KG)
	MAIN		TAP			L	H	
	CONVENTIONAL WIRE SIZE	VERSA-CRIMP SYSTEM RANGE	CONVENTIONAL WIRE SIZE	VERSA-CRIMP SYSTEM RANGE				
VACT1010	1/0 Str. Al/Cu	#8-1/0 Str. Al/Cu	1/0 Str. Al/Cu	#8-1/0 Str. Al/Cu	VC6 (ALL)	4-1/2 (114.3)	2-5/8 (66.7)	.106 (.05)
VACT4040	4/0 Str. Al/Cu	#2-4/0 Str. Al/Cu	4/0 Str. Al/Cu	#2-4/0 Str. Al/Cu	VC6 (ALL)	5-1/4 (133.4)	3-1/16 (77.8)	.237 (.11)
VACT300300	300 MCM Al/Cu	1/0-300 MCM Al/Cu	300 MCM Al/Cu	1/0-300 MCM Al/Cu	VC6 (ALL)	5-1/2 (139.7)	3-5/16 (84.2)	.350 (.16)
VACT500500	500 MCM Al/Cu	4/0-500 MCM Al/Cu	500 MCM Al/Cu	4/0-500 MCM Al-Cu	VC6 (ALL)	7-9/16 (192.1)	4-7/16 (112.7)	.579 (.26)
VACT750750	750 MCM Al	500-750 MCM Al 500 MCM Cu	750 MCM Al	500-750 MCM Al 500 MCM Cu	VC6 (ALL)	8-13/16 (223.9)	5-1/4 (133.4)	.747 (.34)

Refer to page DC-30 & DC-31 for recommended tool and die information.

HIGH VOLTAGE APPLICATIONS—All Aluminum/Copper and Copper Lugs (VCEL, VACL, VHCL, VHCS and VCELC) are rated at 34.5 KV. The other U.L. listed compression connectors (VACS, VACT, VCCT, VHSS and VHS) have a maximum UL voltage requirement of less than 2000 volts, however Anderson recommends these connectors for application through 34.5 KV subject to the manufacturers' limitations and recommendations for the insulation material. For further information, contact factory.



VERSA-CRIMP® ALUMINUM COMPRESSION TAP

ALUMINUM
VCL

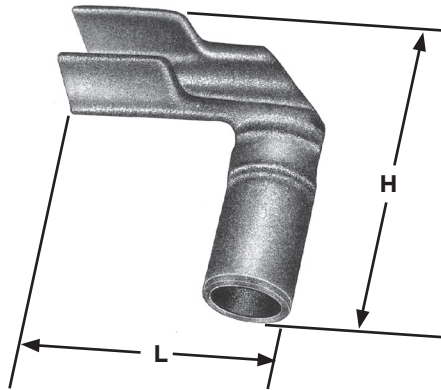

- For use with VERSA-CRIMP® Type VC6 (all) tools only.
- For aluminum to aluminum or aluminum to copper conductor connections.
- Aluminum alloy conductor recommendations include 5005, 6201 (AAAC) and ACAR which are of the same diameter as a given ACSR conductor shown below.

Material: Aluminum Alloy
Factory inhibited

DC
20

Product Data & Conductor Size

CATALOG NUMBER	CONDUCTOR RANGE		VERSA-CRIMP TOOL TYPE	DIMENSIONS INCHES (MM)		APPROX. WT. EACH LBS. (KG)
	MAIN	TAP		L	H	
VCL54	#6 (7)–2/0 (19) AAC #6 (6/1)–2/0 (6/1) ACSR #6 (7)–#1 (19) Cu	#8 (7)–1/0 (19) AAC #8 (6/1)–1/0 (6/1) ACSR #10 Sol.–#2 (7) Cu	VC6 (ALL)	2-11/16 (68.26)	2-1/2 (63.5)	.17 (.08)
VCL64	#4 (7)–4/0 (19) AAC #4 (6/1)–4/0 (6/1) ACSR #4 (7)–2/0 (19) Cu	#8 (7)–1/0 (19) AAC #8 (6/1)–1/0 (6/1) ACSR #10 Sol.–#2 (7) Cu		2-23/32 (69.06)	2-33/64 (63.90)	.19 (.09)
VCL66	#4 (7)–4/0 (19) AAC #4 (6/1)–4/0 (6/1) ACSR #4 (7)–2/0 (19) Cu	#4 (7)–4/0 (19) AAC #4 (6/1)–4/0 (6/1) ACSR #4 Sol.–2/0 (19) Cu		2-31/32 (75.41)	3-19/64 (83.74)	.26 (.12)

VERSA-CRIMP® ALUMINUM COMPRESSION TAP

ALUMINUM
VC2T

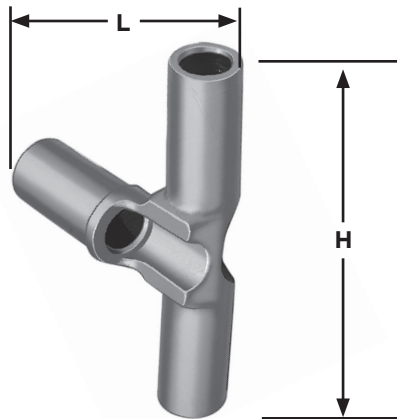

- For use with VERSA-CRIMP® Type VC6 (all) tools only.
- For aluminum to aluminum or aluminum to copper conductor connections.
- Aluminum alloy conductor recommendations include 5005, 6201 (AAAC) and ACAR which are of the same diameter as a given ACSR conductor shown below.

Material: Aluminum Alloy
Factory inhibited

Product Data & Conductor Size

CATALOG NUMBER	CONDUCTOR RANGE (AWG)		VERSA-CRIMP TOOL TYPE	DIMENSIONS INCHES (MM)		APPROX. WT. EACH LBS. (KG)
	MAIN	TAP		L	H	
VC2T66	#4 Sol.–4/0 (19) AAC #4 (6/1)–4/0 (6/1) ACSR #4 Sol.–2/0 (19) Cu	#4 Sol.–4/0 (19) AAC #4 (6/1)–4/0 (6/1) ACSR #4 Sol.–2/0 (19) Cu	VC6 (ALL)	3-1/8 (79.4)	5-7/16 (138.1)	.40 (.18)



VERSA-CRIMP® ALUMINUM COMPRESSION TEE

ALUMINUM
VCT

- For use with VERSA-CRIMP® Type VC6 (all) tools only.
- For aluminum to aluminum or aluminum to copper conductor tee connections.
- Aluminum alloy conductor recommendations include 5005, 6201 (AAAC) and ACAR having the same diameter as a given ACSR conductor shown below.

Material: Aluminum Alloy
Factory inhibited



FIGURE 1

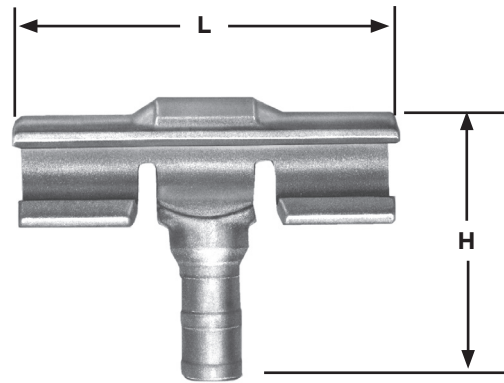

FIGURE 2

DC
21

Product Data & Conductor Size

CATALOG NUMBER	FIGURE NO.	CONDUCTOR RANGE (AWG OR MCM)		VERSA-CRIMP TOOL TYPE	DIMENSIONS INCHES (MM)		APPROX. WT. EACH LBS. (KG)
		MAIN	TAP		L	H	
VCT55	1	#6 (7)-2/0 (19) AAC #6 (6/1)-2/0 (6/1) ACSR	#6 (7)-2/0 (19) AAC #6 (6/1)-2/0 (6/1) ACSR #6 Sol.-#1 (19) Cu	VC6 (ALL)	4-1/16 (103.2)	2-7/8 (73.0)	.55 (.25)
VCT95	2	3/0 (7)-500 (37) AAC 3/0 (6/1)-477 (18/1) ACSR	#6 (7)-2/0 (19) AAC #6 (6/1)-2/0 (6/1) ACSR #6 Sol.-1/0 (19) Cu	VC63 VC6FT	5-5/16 (134.9)	4-7/16 (112.7)	.93 (.42)
VCT96	2	3/0 (7)-500 (37) AAC 3/0 (6/1)-477 (18/1) ACSR	1/0 (7)-4/0 (19) AAC 1/0 (6/1)-4/0 (6/1) ACSR 1/0 (7)-3/0 (19) Cu	VC63 VC6FT	5-5/16 (134.9)	4-7/16 (112.7)	.97 (.44)
VCT99	2	3/0 (7)-500 (37) AAC 3/0 (6/1)-477 (18/1) ACSR	4/0 (7)-350 (37) AAC 4/0 (6/1)-477 (18/1) ACSR 4/0 (7)-350 (37) Cu	VC63 VC6FT	5-5/16 (134.9)	6-7/16 (163.5)	1.20 (.54)



VERSA-CRIMP® ALUMINUM COMPRESSION TAP

ALUMINUM
VCU

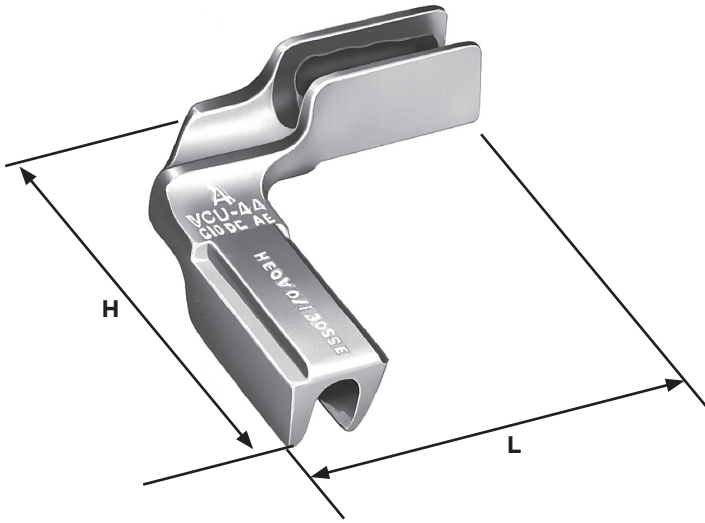

- For use with VERSA-CRIMP® Type VC6 (all) tools.
- For aluminum to aluminum or aluminum to copper conductors.
- Aluminum alloy conductor recommendations include 5005, 6201 (AAAC) and ACAR which are of the same diameter as a given ACSR conductor shown below.

Material: Aluminum Alloy
Factory inhibited

DC
22

Product Data & Conductor Size

CATALOG NUMBER	CONDUCTOR RANGE		VERSA-CRIMP TOOL TYPE	DIMENSIONS INCHES (MM)		APPROX. WT. EACH LBS. (KG)
	MAIN	TAP		L	H	
VCU55	#6 (7)-2/0 (19) AAC #6 (6/1)-2/0 (6/1) ACSR #8 (7)-#4 (7) Cu	#6 (7)-2/0 (19) AAC #6 (6/1)-2/0 (6/1) ACSR #8 (7)-#4 (7) Cu	VC6 (ALL)	3-1/8 (79.38)	3-1/8 (79.38)	.18 (.08)
VCU65	#4 (7)-4/0 (19) AAC #4 (6/1)-4/0 (6/1) ACSR #4 (7)-2/0 (19) Cu	#6 (7)-2/0 (19) AAC #6 (6/1)-2/0 (6/1) ACSR #8 (7)-#4 (7) Cu		3-3/16 (80.96)	3-1/8 (79.38)	.20 (.09)
VCU66	#4 (7)-4/0 (19) AAC #4 (6/1)-4/0 (6/1) ACSR #4 (7)-2/0 (19) Cu	#4 (7)-4/0 (19) AAC #4 (6/1)-4/0 (6/1) ACSR #4 (7)-2/0 (19) Cu		3-3/16 (80.96)	3-3/16 (80.96)	.24 (.11)

VACL/VACS/VACT—Anderson/Burndy

Catalog Number VACL (3) VACS (4) VACT (4)	ANDERSON™ VERSA-CRIMP® COMPRESSION TOOLS (Crimps per Connection)							CONVENTIONAL COMPRESSION DIE TOOLING (Crimps per Connection)															
	V-C Tools Wire Range (AWG or MCM)	VERSA-CRIMP Tools (Number of Crimps)					Wire Size (AWG or MCM)	Die Color Code (2)	Burndy (Crimps)						Burndy Indentor Tools (1 Crimp)								
		*VC6 500	VC6 350	VC6 (1)	VC6 FT (1)	VC8 AL NIBS			Die Index No.	Tool Y34A Die	Tools Y35 Y39 Die	Tool Y34B Die	Tool Y48B Die	Tool Y486RB Die	Tool MY-29 Die	Tool Y34A (Inden-tor) Nest	Tool Y34B (Inden-tor) Nest	Tool Y48B (Inden-tor) Nest	Tool Y486RB (Inden-tor) Nest				
-8	#8 AL/CU	1	1				#8 AL/CU	Blue	374		U8CABT (2)					#8 (1)							
-6	#6 AL/CU	1	1				#6 AL/CU	Gray	346	A6CAB (1)	U6CABT (1)	B6CD (1)				#6 (1)	A4CD (Y34PA)	B4CD (Y34PA)					
-4	#4 AL/CU	2	2				#4 AL/CU	Green	375	A4CAB (1)	U4CABT * (1)	B4CD (1)	C4CAB (1)			#4 (1)	A1CD (Y34PA)	B1CD (Y34PA)					
-2	#6-#2 AL/CU	2	2	2	2		#2 AL/CU	Pink	348	A2CAB (1)	U2CABT (1)	B2CD (1)				#2 (2)	A26D (Y34PA)	B26D (Y34PA)					
-1	#8-#1 AL/CU	2	2	2	2		#1 AL/CU	Tan	296	A25AR (1)	U25ART * (1)	B1CD (1)				#1 (2)	A27D (Y34PR-5)	B27D (Y34PR-5)					
-1/0	#8-1/0 AL/CU	2	2	2	2		1/0 AL/CU	Tan	296	A25AR (1)	U25ART * (1)	B25D (1)				1/0 (2)	A27D (Y34PR-5)	B27D (Y34PR-5)					
-2/0	#4-2/0 AL/CU	2	2	2	2		2/0 AL/CU	Olive	297	A26AR (2)	U26ART (2)	B26D (1)				2/0 (2)	A29D (Y34PR-5)	B29D (Y34PR-5)					
-3/0	#4-3/0 AL/CU	2	2	2	2		3/0 AL/CU	Ruby	467	A27AR (2)	U27ART (2)	B27D (1)				3/0 (2)	A30D (Y34PR-5)	B30D (Y34PR-5)					
-4/0	#2-4/0 AL/CU	3	3	2	2		4/0 AL/CU	White	298	A28AR (2)	U28ART (2)	B28D (1)	C28AR (1)	F28AR (1)		4/0 (2)	A31D (Y34PR-5)	B31D (Y34PR-5)					
-250	1/0-250 AL/CU	3	3	2	2		250 AL/CU	Red	324	A29AR (2)	U29ART (2)	B29D (1)	C29AR (1)	F29AR (1)			A32D (Y34PR-5)	B32D (Y34PR-5)					
-300	1/0-300 AL/CU	3	3	2	2		300 AL/CU	Blue	470	A30AR (2)	U30ART (2)	B30D (2)	C30AR (1)	F30AR (1)			A34D (Y34PR-11)	No Die	C34D (Y48PR-1)	F34D (Y48PR-1)			
-350 (1)	2/0-350 AL/CU	4		3	3		350 AL/CU	Brown	299		U31ART (2)	B31D (2)	C31AR (1)	F31AR (1)					C35D (Y48PR-1)	F35D (Y48PR-1)			
-400 (1)	3/0-400 AL/CU	5		4 O'lap	4 O'lap		400 AL/CU	Green	472		U32ART (4)	B32D (2)	C32AR (2)	F32AR (2)					C36D (Y48PR-1)	F36D (Y48PR-1)			
-500 (1)	4/0-500 AL/CU	7		4 O'lap	4 O'lap		500 AL/CU	Green	472		U32ART (4)	No Die Required (2)	C32AR (2)	F32AR (2)									
-600	350 - 600 AL 350 - 500 CU				4	3	600 AL	Pink	300		U34ART (4)		C34AR (2)	F34AR (2)									
-750	500 - 750 AL 500 CU				4	3	750 AL	Pink	300		U34ART (4)		C34AR (2)	F34AR (2)									
-1000	750-1000 AL					3	1000 AL	Brown	302				C44AR (2)	F44AR (2)					C46D (Y48PR-1)	F46D (Y48PR-1)			

+ TBM-8 Tool ONLY

★ Anderson HC-12 Dies, Burndy's Y-35 Dies and Blackburn's JB-12 Dies are interchangeable.

(1) "VACL" Lug sizes -350 to -500 take 1 less crimp (VC6 Tools) than shown.

(2) Color code is for Anderson and Burndy dies only. Use the recommended die number (NOT die color) for Blackburn, Kearney & T&B Hyd. Tools/Dies.

(3) The "VACL" lugs are qualified for UL "HV" applications.

(4) The "VACS" sleeves and "VACT" tee connectors are for AL to AL or AL to CU connections ONLY. (NOT for CU to CU connections).

* Not UL Listed-pending completion of test.





VACL/VACS/VACT—Anderson/Burndy

Catalog Number VACL ⁽³⁾ VACS ⁽⁴⁾ VACT ⁽⁴⁾	ANDERSON™ VERSA-CRIMP® COMPRESSION TOOLS (Crimps per Connection)						CONVENTIONAL COMPRESSION DIE TOOLING (Crimps per Connection)										
	V-C Tools Wire Range (AWG or MCM)	VERSA-CRIMP Tools (Number of Crimps)					Wire Size (AWG or MCM)	Die Color Code ⁽²⁾	Blackburn (Crimps)		Kearney (Crimps)			Thomas & Betts (Crimps)			
		*VC6 500	VC6 350	VC6 ⁽¹⁾	VC6 FT ⁽¹⁾	VC8 AL NIBS			Tool OD-58	Tool JB-12A	Tools (No. of Crimps)			Tools TBM5 TBM8	12 Ton Hyd. Tool	15 Ton Hyd. Tool	
											O-52	WH-1 PH-1	WH-2 PH-2				
Die	Die	Die	O-52	WH-1 PH-1	WH-2 PH-2	Die	Die	Die									
-8	#8 AL/CU	1	1			#8 AL/CU	Blue	BY17C (2)	B73CH (1)	1/4	(2)			Blue (1)	24 (1)	24 (1)	
-6	#6 AL/CU	1	1			#6 AL/CU	Gray	BY19C (3)	B74CH (1)	5/16	(3)	(1)	(1)	Gray (2)	29 (2)	29 (2)	
-4	#4 AL/CU	2	2			#4 AL/CU	Green	BY21C (3)	U4CABT * (1)	3/8	(3)	(2)	(2)	Green (2)	37 (2)	37 (2)	
-2	#6-#2 AL/CU	2	2	2	2	#2 AL/CU	Pink	BY23C (3)	BO6CH (1)	1/2	(3)	(2)	(2)	Pink (2)	45 (2)	45 (2)	
-1	#8-#1 AL/CU	2	2	2	2	#1 AL/CU	Tan	BY23C (4)	U25ART * (1)	9/16	(4)	(2)	(2)	Tan (2)	50 (2)	50 (2)	
-1/0	#8-1/0 AL/CU	2	2	2	2	1/0 AL/CU	Tan	BY25C (4)	U25ART * (1)	9/16	(4)	(2)	(2)	Tan (2)	50 (2)	50 (2)	
-2/0	#4-2/0 AL/CU	2	2	2	2	2/0 AL/CU	Olive	BY31C (4)	B09CH (2)	5/8-1	(4)	(3)	(3)	Olive (2)	54 (1)	54H (2)	
-3/0	#4-3/0 AL/CU	2	2	2	2	3/0 AL/CU	Ruby	BY27C (5)	B26CH (2)	11/16	(5)	(3)	(3)	Ruby (2)	62 (1)	62 (1)	
-4/0	#2-4/0 AL/CU	3	3	2	2	4/0 AL/CU	White	BY35C (5)	B10CH1 (2)	7/8	(5)	(3)	(3)	+White (4)	71H (3)	71H (3)	
-250	1/0-250 AL/CU	3	3	2	2	250 AL/CU	Red	BY37C (5)	B11CH (2)	8/40	(5)	(3)	(3)	+Red (5)	76H (3)	76 (2)	
-300	1/0-300 AL/CU	3	3	2	2	300 AL/CU	Blue		B61EA (1)	29/32		(2)	(2)	+Blue (5)	87H (3)	87H (3)	
-350 ⁽¹⁾	2/0-350 AL/CU	4		3	3	350 AL/CU	Brown		B12CH1 (2)	1-1/8-1		(2)	(2)	+Brown (5)	94H (3)	94H (3)	
-400 ⁽¹⁾	3/0-400 AL/CU	5		4 O'lap	4 O'lap	400 AL/CU	Green		B80EA (2)	1-1/8-1		(2)	(2)		99H (3)	99H (3)	
-500 ⁽¹⁾	4/0-500 AL/CU	7		4 O'lap	4 O'lap	500 AL/CU	Green		B80EA (3)	1-1/8-2		(2)	(2)		96H (4)	96 (2)	
-600	350 - 600 AL 350 - 500 CU				4	600 AL	Pink		B20AH (3)	1-5/16			(4)		106H (5)	106H (5)	
-750	500 - 750 AL 500 CU				4	750 AL	Pink		B20AH (3)	1-5/16			(4)		106H (5)	106H (5)	
-1000	750-1000 AL					1000 AL	Brown										

+ TBM-8 Tool ONLY
★ Anderson HC-12 Dies, Burndy's Y-35 Dies and Blackburn's JB-12 Dies are interchangeable.
(1) "VACL" Lug sizes -350 to -500 take 1 less crimp (VC6 Tools) than shown.
(2) Color code is for Anderson and Burndy dies only. Use the recommended die number (NOT die color) for Blackburn, Kearney & T&B Hyd. Tools/Dies.
(3) The "VACL" lugs are qualified for UL "HV" applications.
(4) The "VACS" sleeves and "VACT" tee connectors are for AL to AL or AL to CU connections ONLY. (NOT for CU to CU connections).
* Not UL Listed-pending completion of test.