

Rotofold Ball Valve Manifold

The HOKE® Rotofold ball valve manifold has a unique design that utilizes quarter turn ball valves for blocking process impulse lines and performing equalizing functions. They also provide easy rod through of all passages when clean-out is necessary. PCPTFE seats and PPTFE stem packing are easily replaced if maintenance is required. The pipe by flange Rotofold design allows the manifold to be directly mounted to integral orifice transmitters by simply reversing the flanges and flange fittings. The pipe by pipe Rotofold design allows the manifold to be remotely mounted separately from the process.

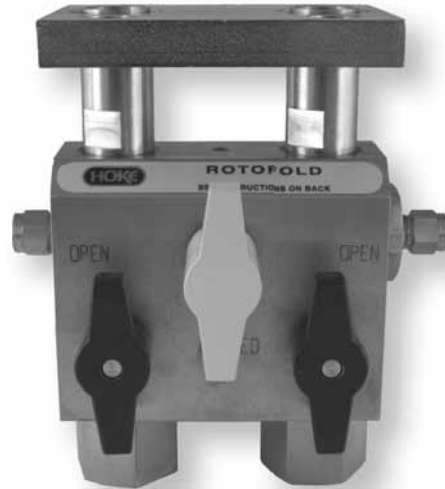

instrument manifolds

Technical Data

MAXIMUM OPERATING PRESSURE	6000 psig (414 barg) -65° F to +150° F (-54° C to +66° C)
OPERATING TEMPERATURE RANGE	400 psig @ +300° F (28 barg @ +149° C) 0° F to +300° F (-18° C to +149° C)

Pressure Temperature Curves

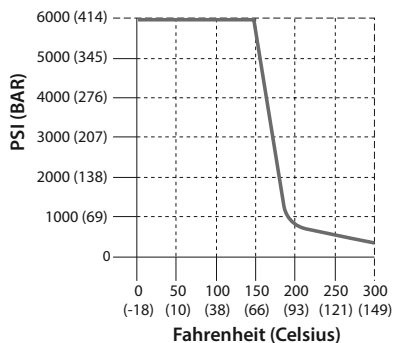

Features & Specifications

- Flange can be reversed for direct mounting to an integral orifice type transmitter.
- Connections on instrument side of block valves for bleeding and venting.
- Replaceable PCPTFE seats on all valves provide longer service life.
- All media passages can be rodded for easy cleaning.
- ¼ turn handle provides visual indication of valve mode.
- Mounting bolts and PTFE gaskets are standard with flange models.
- Cam handles provide error-proof sequencing of valves.
- Mani-Mount mounting kit available for NPT pipe style (see Mani-mount mounting system, page 17)
- Special High Tolerance NPT Thread

Cam-Valve Interlocking Sequencing Handles

The correct sequencing of opening and closing manifold valves is critical to eliminating pressure transmitter damage due to over ranging. By attaching cams to the equalizing and block valve handles, the inter-locking design assures proper initial service and transmitter zeroing during calibration.

Cam kit **8200KS** can be field installed or factory assembled to the manifold at time of order. For factory assembled, add part number **8200KS** to the end of the manifold part number.

Rotofold Ball Valve Manifold - Pipe by Flange

Special Application Manifolds

Dimensions and Materials

Dimensions are in inches (millimeters) are for reference only and are subject to change

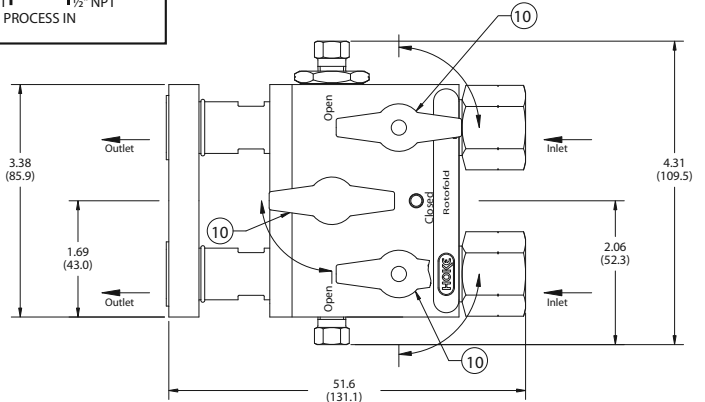
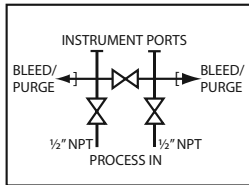
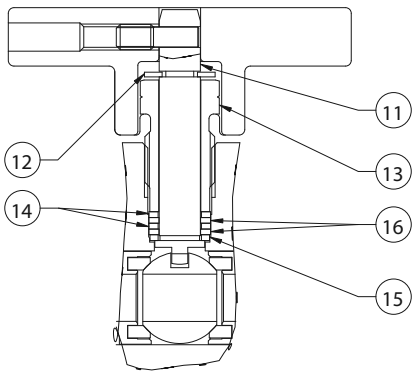
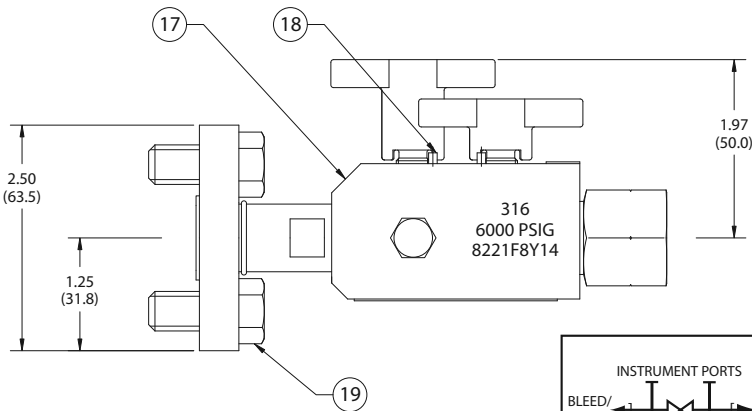
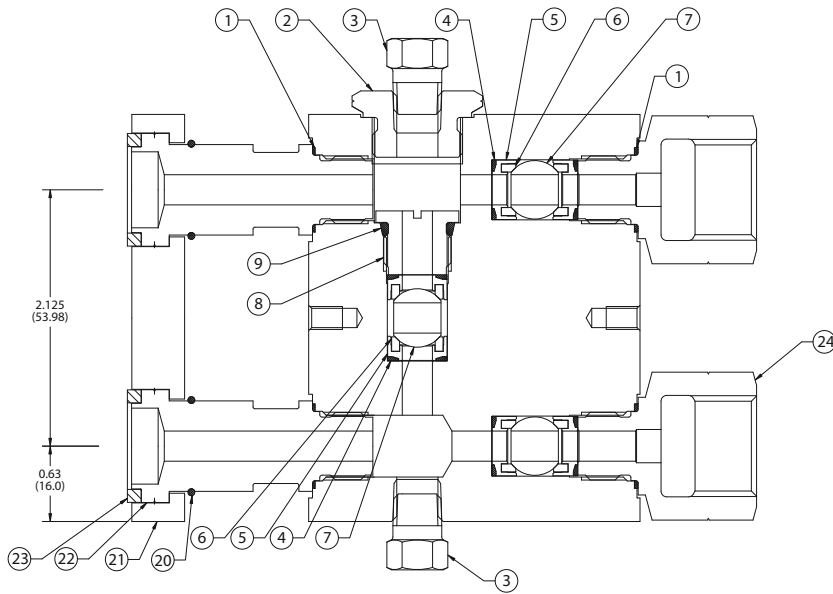

	DESCRIPTION	MATERIAL
1	PLUG WASHER	PPTFE
2	VENT FITTING	316 stainless steel
3	PIPE PLUG	316 stainless steel
4	WASHER	Viton®
5	SEAT RETAINER	316 stainless steel
6	SEAT	PCPTFE
7	BALL	316 stainless steel
8	INSERT	316 stainless steel
9	O-RING	Fluorelastomer
10	HANDLE	Aluminum alloy 360
11	STEM	316 stainless steel
12	RETAINING RING	PH15-7MO
13	STEM RETAINER	316 stainless steel
14	SHIM WASHER	316 stainless steel
15	SHIM WASHER	316 stainless steel
16	SHIM WASHER	PPTFE
17	MANIFOLD BODY	316 stainless steel
18	SPIRAL PIN	302 stainless steel
19	CAP SCREW	Carbon Steel
20	RETAINING RING	302 stainless steel
21	FLANGE	Carbon Steel
22	FLANGE CONNECTOR	316 stainless steel
23	WASHER	PPTFE
24	END FITTING	316 stainless steel

How to Order Rotofold-Pipe by Flange

CONNECTIONS			PART NUMBER
BODY OUTLET STYLE	INLET PROCESS	OUTLET INSTRUMENTATION	
Flange	1/2" Female NPT	Flange	8221F8Y

Cam-valve sequencing handles order Part # **8200K5**

Mani-Mount mounting module - see page 17 for details (available for **8221F8Y** only)

Rotofold Ball Valve Manifold - Pipe by Pipe

Special Application Manifolds

Dimensions and Materials

Dimensions are in inches (millimeters) are for reference only and are subject to change

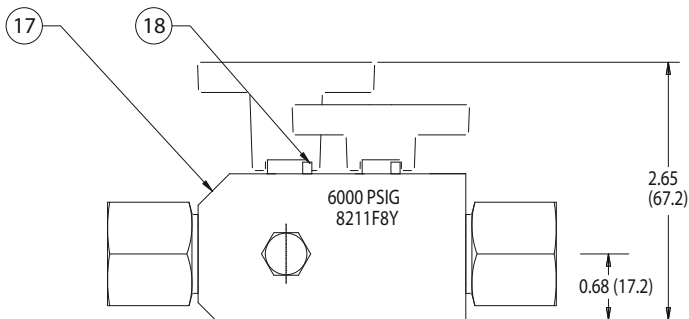
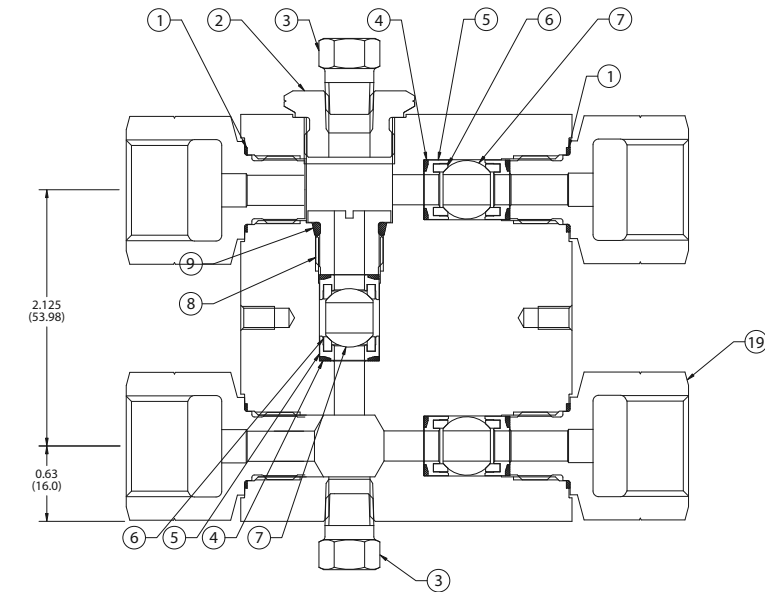

	DESCRIPTION	MATERIAL
1	PLUG WASHER	PPTFE
2	VENT FITTING	316 stainless steel
3	PIPE PLUG	316 stainless steel
4	WASHER	Viton®
5	SEAT RETAINER	316 stainless steel
6	SEAT	PCPTFE
7	BALL	316 stainless steel
8	INSERT	316 stainless steel
9	O-RING	Fluorelastomer
10	HANDLE	Aluminum alloy 360
11	STEM	316 stainless steel
12	RETAINING RING	PH15-7MO
13	STEM RETAINER	316 stainless steel
14	SHIM WASHER	316 stainless steel
15	SHIM WASHER	316 stainless steel
16	SHIM WASHER	PPTFE
17	MANIFOLD BODY	316 stainless steel
18	SPIRAL PIN	302 stainless steel
19	END FITTING	316 stainless steel

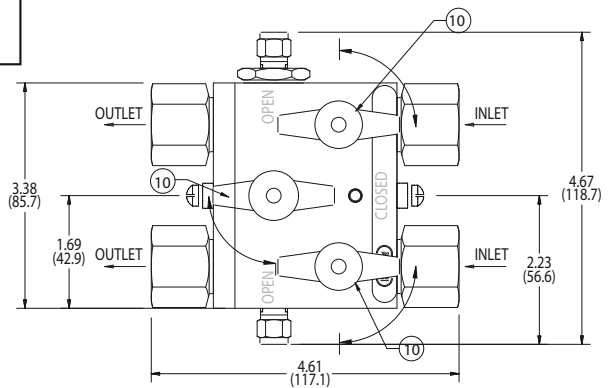
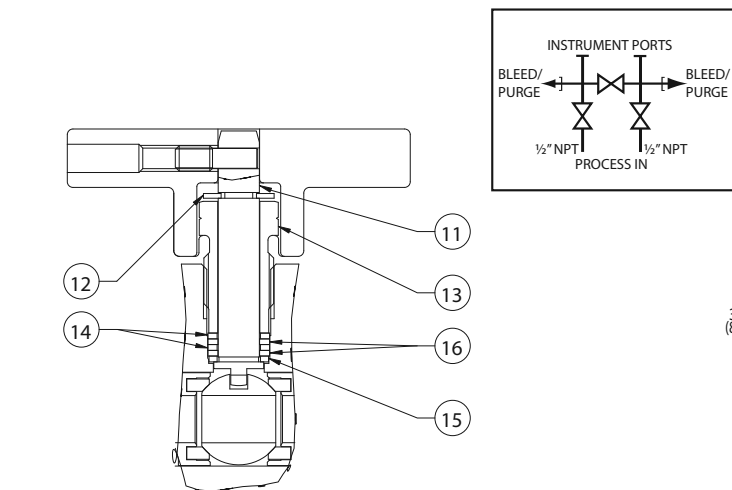

How to Order Rotofold-Pipe by Pipe

CONNECTIONS			PART NUMBER
BODY OUTLET STYLE	INLET PROCESS	OUTLET INSTRUMENTATION	
NPT Pipe	½" Female NPT	½" Female NPT	8211F8Y

Cam-valve sequencing handles order Part # **8200K5**